



INSTALLATION INSTRUCTIONS – SQUEEZE OFF-TOOL

Squeezing of carrier pipes – retrofitting of pipe components



INFORMATION AND SAFETY WARNINGS

Notes about these installation instructions

Validity

These installation instructions are valid worldwide.

Pictograms and logos



Safety information



Legal information



Important information that must be noted



Proper use

The REHAU pipe systems and their components must only be planned, installed and operated as described in the current applicable technical information or in the relevant installation instructions. Any other use is improper and therefore prohibited.

For more detailed advice, please contact your REHAU sales office. Proper use entails compliance with all of the instructions in the technical information as well as the installation, operating and maintenance instructions. We accept no liability for improper use or prohibited modifications to the product and all resultant consequences.



Currentness of the installation instructions

To ensure your own safety and the correct use of our products, please check at regular intervals whether a newer version of these installation instructions is available. The issue date of your installation instructions is always printed in the bottom left-hand corner of the cover page. You can obtain the current installation instructions from your REHAU sales office, specialist wholesaler or you can download it from www.rehau.uk.

Safety warnings and operating instructions

- For your own safety and the safety of other people, please read all safety warnings and operating instructions carefully and in full before commencing installation.
- Keep the installation instructions handy for easy access
- If you do not understand the safety warnings or the individual installation regulations, or if there is any uncertainty with regard to their content, please contact your local REHAU sales office.
- **Non-compliance with the safety information may lead to damage to property or personal injury**



Observe all applicable national and international regulations relating to laying, installation, safety and the prevention of accidents when installing pipe systems, as well as the instructions in the technical information and these installation instructions. Please also observe the applicable laws, standards, instructions and regulations (e.g. DIN, EN, ISO, DVGW, TRGI, VDE and VDI) as well as regulations on environmental protection, regulations of the Employer's Liability Insurance Association and specifications of the local public utilities companies. Please ensure that the guidelines, standards and regulations in use are the valid version in each case. The design and assembly instructions relate directly to the REHAU product in each case. Some sections refer to generally applicable standards or regulations.

More specific standards, regulations and instructions relating to the planning, installation and operation of drinking water or heating systems or systems for building services must also be observed and do not form part of this technical information.

Areas of application not included in the technical information (special applications) require consultation with our Technical Applications Department.



Personnel requirements

- Only authorised and trained persons are permitted to install our systems
- Work on electrical equipment or wiring may only be performed by authorised and qualified electricians

General precautions

- Keep your workplace clean and free of obstructions
- Ensure that your workplace is adequately lit
- Keep children, pets and unauthorised persons away from tools and the installation areas. This applies particularly in the case of renovation work in an occupied area
- Only use the components intended for the respective REHAU system. The application of components from other systems or the use of tools which do not come from the relevant REHAU installation system can result in accidents or other hazards

Working clothes

- Wear protective goggles, suitable working clothes, safety shoes, a hard hat and a hairnet if you have long hair
- Do not wear loose-fitting clothing or jewellery as they may get caught in moving parts

During installation

- Always read and follow the operating instructions for the REHAU installation tool you are using
- Improper handling of tools can result in severe cuts, trapped or severed limbs
- Improper handling of tools can damage the jointing components and result in leaks
- REHAU pipe cutters have a sharp blade. Store and handle them in such a way that there is no risk of injury from the REHAU pipe cutters
- When cutting the pipes to size, maintain a safe distance between the hand holding the pipe and the cutting tool
- Never put your hand in the tool's cutting zone or on moving parts during the cutting process
- Following the expansion process, the expanded pipe end returns to its original shape (memory effect). Do not insert any foreign objects into the expanded pipe end during this stage
- Never put your hand in the tool's compression zone or on moving parts during the compression process
- The fitting may fall out of the pipe until the compression process is complete. Risk of injury!
- During maintenance or retooling work and when changing the installation area, always unplug the tool and prevent it from being switched on accidentally



Operating parameters

- If the operating parameters are exceeded, excessive stress is placed on the pipes and connections. It is therefore not permissible to exceed the operating parameters
- Adherence to the operating parameters is to be ensured via safety and control facilities (e.g. pressure reducer, safety valves and similar)

System-specific safety warnings

- Deburr or remove edges on insulating sleeves in order to prevent possible injury
- When sawing or sanding foamed PUR, a dust mask must be worn
- When welding electrofusion couplers and foam moulding with PUR foam for the shroud, the component heats up
- There is a danger of crushing when working with lashing straps to fix the pipes in place. Do not reach into the hazardous areas
- Only make the connection using suitable installation tools
- The relevant operating instructions, instruction leaflet and technical information must be observed when handling tools and making the connection
- Do not use dirty or damaged connection components or tools
- Cordless or mains-operated tools such as A-light2, A3, E3, G2 are unsuitable for permanent operation. A break of min. 15 minutes must be taken after approx. 50 consecutive compressions to allow the appliance to cool down
- You can find the exact allocation of the connection components in the current price list

GENERAL INFORMATION AND TOOLS

General information

For repair and integration work, e.g. to connect heat consumers retrospectively, RAUTHERMEX and RAUVITHERM PE-Xa carrier pipes can be squeezed. Squeezing-off pipe avoids having to empty a larger pipe section and/or prevents full draining of the system.

In addition to the specifications listed here, those of the technical notification DVGW GW332 must be observed, as well as the information provided by the manufacturer of the squeeze-off tool.

Tools and material

The following types of commercially available squeeze-off tools can be used according to pipe type and dimension:

1. Mechanical squeezing for pipes up to dimensions of 63 x 5.8 mm.
2. Hydraulic/mechanical squeezing from dimensions 75 x 6.8 mm to 160 x 14.6 mm.



Fig. 1 Example squeeze-off tools for various pipe dimensions. Mechanical and/or hydraulic/mechanical

When cutting to length and laying pipes, they can be subject to linear expansion due to temperature and production conditions.

In order to be able to close any gaps which may appear between pipe ends after cutting, two additional pipe sections must be prepared along with the appropriate shroud, accessories and required fittings.

These pipe sections can be either RAUTHERMEX, RAUVITHERM or RAUTHERM FW, as long as they are suitable for heating applications. They will have to be approx 0.5m long and must match the size of the main spine.

The following materials are required for insulating the pipe joint and squeezing points:

Type of connection:	Accessories required for insulation:
T-branch with RAUTHERMEX:	one T-clip shroud, two I-clip shrouds
T-branch with RAUVITHERM:	one T-heat-shrink shroud, four additional heat-shrink sleeves
Connection to blind end with RAUTHERMEX:	two I-clip shrouds
Connection to blind end with RAUVITHERM:	one I-heat-shrink shroud, two additional heat-shrink sleeves

Tab. 1: Material required for insulating when squeezing



- Squeezing-off can be carried out at outdoor temperatures above 5 °C.

- All dimensions of carrier pipe can be squeezed-off, provided the available line pressure can be sufficiently reduced
- The relevant installation instructions 'Clip shroud' and 'Heat-shrink shroud' are to be observed

PREPARATORY WORK STEPS

1. Exposing pipe

For retrospective installation of a T-branch: 4.5 m long; minimum 0.8 m wide (see trench dimensions in Fig. 2 and section (A) Fig. 3); 0.15m working space under the pipe.

For retrospective connection to a blind end: minimum 0.5 m main pipe on both sides and expose blind ends (see trench dimensions in Fig. 8); 0.15m working space under the pipe.

The pipe can be propped up in the working area to improve accessibility.

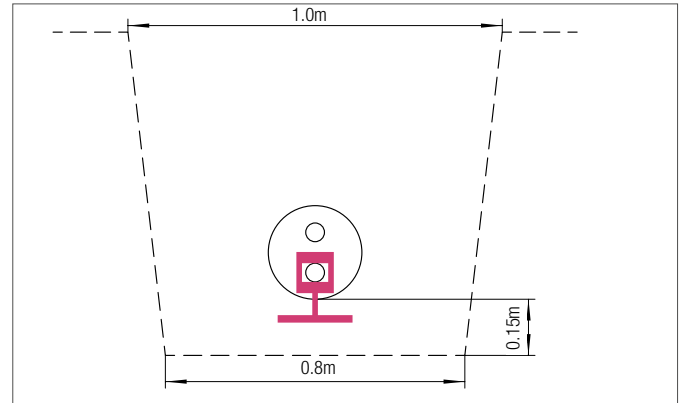



Fig. 2

2. Laying house connection pipe

Lay pipe route from header pipe connection to building entrance including building entrance fitting and ball valve.

3. Further preparations

In order to keep the squeezed-off pipe length to a minimum, installation step 1 (stripping) should be carried out before the squeezing-off process is begun, as well as preparing the other work steps where possible.

 Symbol for squeeze-off tool

INSTALLATION STEPS

(A) Retrospective installation of a T-branch

1. Stripping the insulation

Strip the insulation from the house connection pipe on the end to be connected and the header pipe in three places as per the diagram on Fig 3. This will ensure squeezing-off takes place at a sufficient distance from the pipe ends.

For RAUVITHERM, the removed insulation can be used again later.

For RAUTHERMEX, carefully remove and peel off the outer jacket. Then remove the foam.

Remove left-over PU foam from the carrier pipe with the help of sand paper.

Take care not to damage the carrier pipe in the process.

Clean the pipe sections in the working area (see image on Fig. 4) to prevent contamination of the heat-shrink sleeve and/or sealing rings during installation.

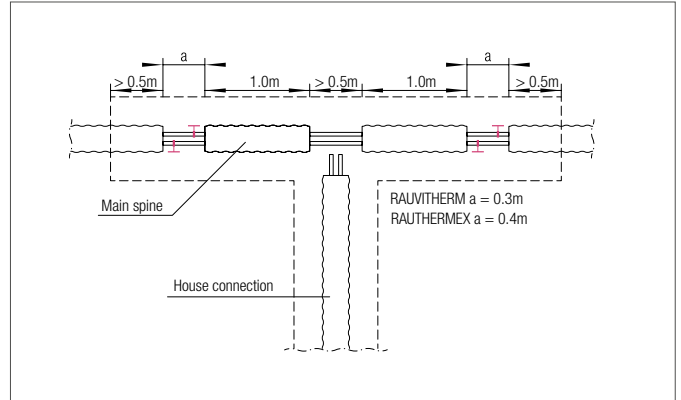



Fig. 3 DUO pipe rotated to show both pipes for illustration purposes.



Fig. 4

2. Squeezing-off

-  - Carrier pipe and squeezing axle must be free from sand and dirt at the squeezing point. Only squeeze-off tools which are in full working order and comply with the requirements specified in GW 332 may be used.
- The squeezing-off point must be a distance of at least 5x the outer diameter of the carrier pipe from the next pipe joint. There must be a distance of at least 6x the outer diameter of the carrier pipe from a previous squeezing-off point.

Adjust the squeeze-off tool to the wall thickness of the pipe using the limit stop and position the squeeze-off tool over the centre of the carrier pipe. Squeezing-off should be performed quickly until the limit stop is reached. When using more than one squeeze-off tool, position according to space available.

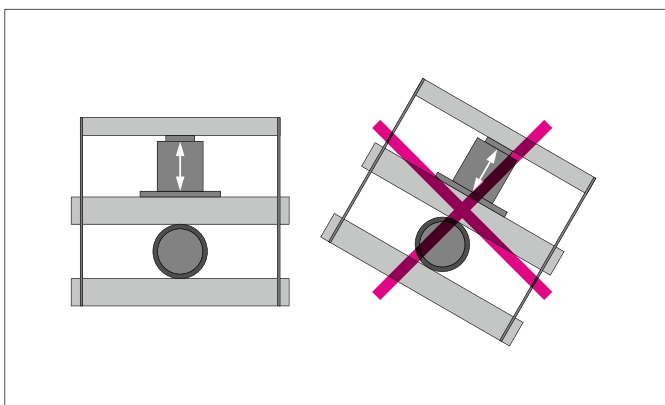
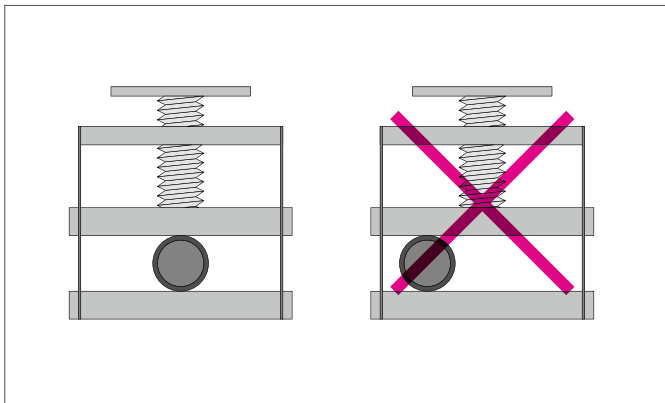

Fig. 5 Hydraulic squeeze-off tool must be kept in an upright position.



3. Cutting through



Scalding hazard

When cutting through pipes, hot water may spray out and injure persons. Exercise caution when cutting through pipes and wear suitable protective clothing.

Risk of accident!

Pipes under pressure may spring out. It must be ensured that the pipes are free from stresses during trimming. The pipe sections to be cut may need to be secured.

Cut through the carrier pipe using a suitable tool. It must be ensured that the cuts run perpendicular to the pipe axis. Burrs and unevenness of the cut surface are to be removed using a suitable tool.



Important: once the pipe has been cut, it contracts to a certain extent. This creates a gap. For this reason, wait for around 10 minutes until no further changes in length can be observed. Only then should the carrier pipes be cut, if required, and fitting inserted.

If the gap becomes too big for the fitting, the pipe can be extended accordingly using an additional coupling and a carrier pipe section.

4. Preparing sleeves/insulation

Before connecting the carrier pipes, the relevant shroud accessories (heat-shrink sleeve and heat-shrink shroud and/or sealing rings) should be slid onto the pipe ends. The installation instructions 'Heat-shrink shroud' or 'Clip shroud' should be observed, as well as installation instructions 'Compression sleeve joint'.

- Main spine: push three heat-shrink sleeves (when using heat-shrink shrouds) onto every pipe end or three sealing rings appropriately aligned (when using clip shrouds) onto every pipe end.
- House connection pipe: push heat-shrink sleeve and opened heat-shrink shroud or sealing ring (when using clip shrouds) onto the pipe end.



When using clip shrouds, pay attention to the alignment of the sealing rings. After final positioning of the sealing rings (see point 7), each of the sealing lips must be pointing towards the inside of the sleeve.

 Symbol for heat-shrink sleeve (for installation of heat-shrink sleeve) respectively sealing ring (for installation of clip shroud)

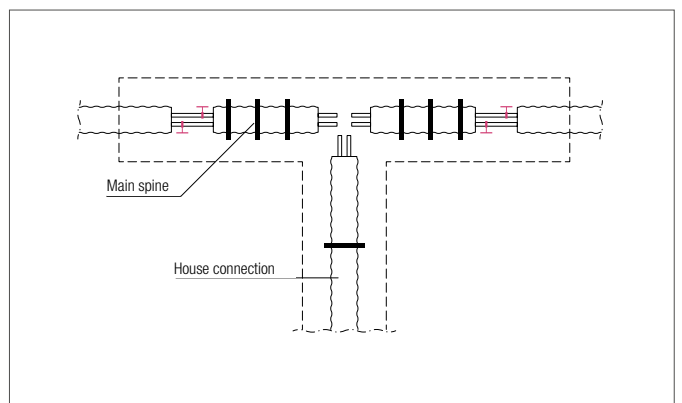

Fig. 6 Arrangement of the heat-shrink sleeves/sealing rings BEFORE jointing

5. Completing the compression sleeve joint

Connect pipes as per installation instructions 'Compression sleeve joint'.

First connect the main pipe, then connect the branch.



Take note of the position of flow and return.



6. Release the squeeze-off tool and aerate the house connection pipe



Risk of water escaping!

When releasing the squeeze-off tool with the house connection open, water may escape. Check that the house connection pipe is fully isolated at the building. Carefully open the shut-off device for subsequent aeration.

- Release the first squeeze-off tool in each flow direction (note the flow and return)
- Connected pipe is still pressurised!
- Carefully open the shut-off device in the house and aerate the pipe
- Release the second squeeze-off tool
- Mark the squeezing point on the carrier pipe

The carrier pipe returns to its original shape due to temperature, pressure and the memory effect of the material PE-Xa .



7. Insulating and sealing

Squeezing-off points are to be subsequently insulated and sealed, once the pipe sections have been pressurised and checked for tightness.

The installation instructions 'Clip shroud' and 'Heat-shrink shroud' are to be observed.

For a RAUVITHERM connection only, the original insulating layers removed during stripping can be used again. The insulating layers can be attached using adhesive tape. Before shrink wrapping the heat-shrinking area, clean again and rough with an abrasive cloth, if required. Warm up surface of pre-insulated pipe before shrink wrapping.

Seal squeezing-off points with two overlapping heat-shrink sleeves each.

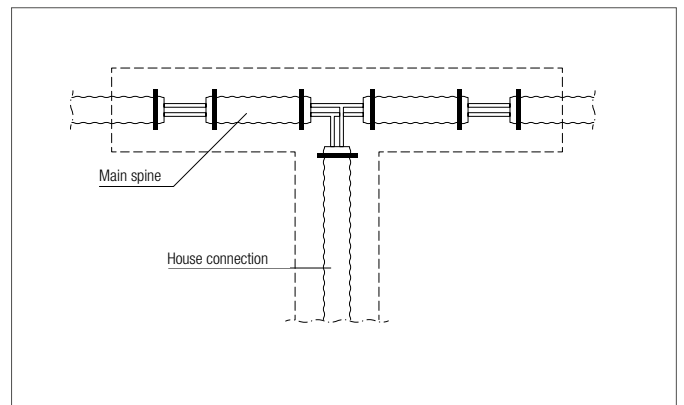

Fig. 7 Arrangement of the heat-shrink sleeve/sealing rings AFTER releasing the squeeze-off tool

(B) Retrospective connection to a blind end

The blind end must be stripped in two places as per the diagram to Fig. 8; the house connection pipe only needs to be stripped on the end to be connected.

For retrospective connection to a blind end, after the step 'Stripping' follow the same procedure as for point A: 'Retrospective installation of a T-branch'.

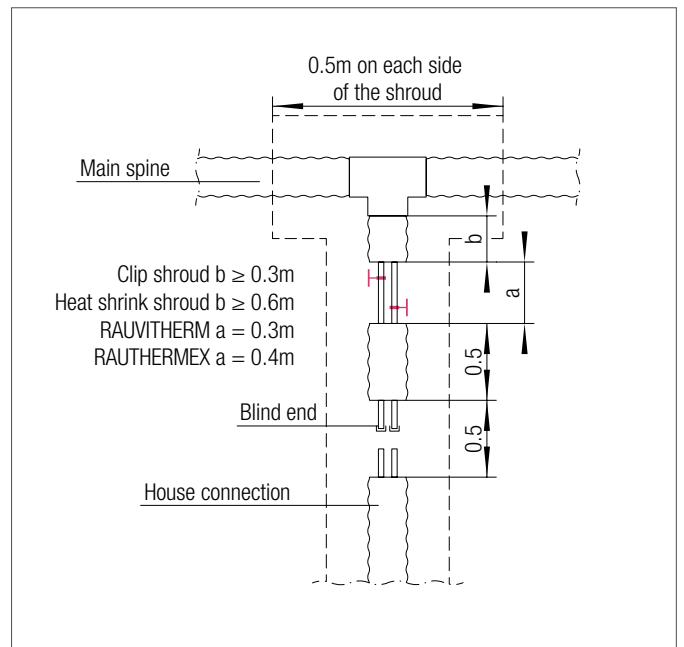

Fig. 8 Connection to a blind end

This document is protected by copyright. All rights based on this are reserved. No part of this publication may be translated, reproduced or transmitted in any form or by any similar means, electronic or mechanical, photocopying, recording or otherwise, or stored in a data retrieval system.

Our verbal and written advice relating to technical applications is based on experience and is to the best of our knowledge correct but is given without obligation. The use of REHAU products in conditions that are beyond our control or for applications other than those specified releases us from any obligation in regard to claims made in respect of the products. We recommend that the suitability of any REHAU product for the intended application should be checked. Utilization and processing of our products are beyond our control and are therefore exclusively your responsibility. In the event that a liability is nevertheless considered, any compensation will be limited to the value of the goods supplied by us and used by you. Our warranty assumes consistent quality of our products in accordance with our specification and in accordance with our general conditions of sale.

REHAU SALES OFFICES

AE: Middle East, +971 4 8835677, dubai@rehaus.com **AR: Buenos Aires**, +54 11 48986000, buenosaires@rehaus.com **AT: Linz**, +43 732 3816100, linz@rehaus.com **Wien**, +43 2236 24684, wien@rehaus.com **Graz**, +43 361 403049, graz@rehaus.com **AU: Adelaide**, +61 8 82990031, adelaide@rehaus.com **Brisbane**, +61 7 55271833, brisbane@rehaus.com **Melbourne**, +61 3 95875544, melbourne@rehaus.com **Perth**, +61 8 94564311, perth@rehaus.com **Sydney**, +61 2 87414500, sydney@rehaus.com **AZ: Baku**, +99 412 5110792, baku@rehaus.com **BA: Sarajevo**, +387 33 475500, sarajevo@rehaus.com **BE: Bruxelles**, +32 16 399911, bruxelles@rehaus.com **BG: Sofia**, +359 2 8920471, sofia@rehaus.com **BR: Arapongas**, +55 43 31522004, arapongas@rehaus.com **Belo Horizonte**, +55 31 33097737, belohorizonte@rehaus.com **Caxias do Sul**, +55 54 32146606, caxias@rehaus.com **Mirassol**, +55 17 32535190, mirassol@rehaus.com **Recife**, +55 81 32028100, recife@rehaus.com **BY: Minsk**, +375 17 2450209, minsk@rehaus.com **CA: Moncton**, +1 506 5382346, moncton@rehaus.com **Montreal**, +1 514 9050345, montreal@rehaus.com **St. John's**, +1 709 7473909, stjohns@rehaus.com **Toronto**, +1 905 3353284, toronto@rehaus.com **Vancouver**, +1 604 6264666, vancouver@rehaus.com **CH: Bern**, +41 31 720120, bern@rehaus.com **Vevey**, +41 21 9482636, vevey@rehaus.com **Zuerich**, +41 44 8397979, zuerich@rehaus.com **CN: Guangzhou**, +86 20 87760343, guangzhou@rehaus.com **Beijing**, +86 10 64282956, beijing@rehaus.com **Shanghai**, +86 21 63551155, shanghai@rehaus.com **Chengdu**, +86 28 86283218, chengdu@rehaus.com **Xian**, +86 29 68597000, xian@rehaus.com **Shenyang**, +86 24 22876807, shenyang@rehaus.com **Qingdao**, +86 32 86678190, qingdao@rehaus.com **CO: Bogota**, +57 1 898 528687, bogota@rehaus.com **CZ: Praha**, +420 272 190111, praha@rehaus.com **DE: Berlin**, +49 30 667660, berlin@rehaus.com **Bielefeld**, +49 521 208400, bielefeld@rehaus.com **Bochum**, +49 234 689030, bochum@rehaus.com **Frankfurt**, +49 6074 40900, frankfurt@rehaus.com **Hamburg**, +49 40 733402100, hamburg@rehaus.com **Leipzig**, +49 34292 820, leipzig@rehaus.com **München**, +49 8102 860, muenchen@rehaus.com **Nürnberg**, +49 9131 934080, nuernberg@rehaus.com **Stuttgart**, +49 7159 16010, stuttgart@rehaus.com **DK: København**, +45 46 773700, københavn@rehaus.com **EE: Tallinn**, +372 6025850, tallinn@rehaus.com **ES: Barcelona**, +34 93 6353500, barcelona@rehaus.com **Bilbao**, +34 94 4538636, bilbao@rehaus.com **Madrid**, +34 91 6839425, madrid@rehaus.com **FI: Helsinki**, +358 9 87709900, helsinki@rehaus.com **FR: Lyon**, +33 4 72026300, lyon@rehaus.com **Metz**, +33 6 8500, metz@rehaus.com **Paris**, +33 1 34836450, paris@rehaus.com **GB: Glasgow**, +44 1698 503700, glasgow@rehaus.com **Manchester**, +44 161 7777400, manchester@rehaus.com **Slough**, +44 1753 588500, slough@rehaus.com **Rosswy**, +44 1989 762643, rowy@rehaus.com **London**, +44 207 3078590, london@rehaus.com **GE: Tbilisi**, +995 32 559909, tbilisi@rehaus.com **GR: Athens**, +30 21 06682500, athens@rehaus.com **Thessaloniki**, +30 2310 633301, thessaloniki@rehaus.com **HK: Hongkong**, +85 2 28987080, hongkong@rehaus.com **HR: Zagreb**, +385 1 3444711, zagreb@rehaus.com **HU: Budapest**, +36 23 530700, budapest@rehaus.com **ID: Jakarta**, +62 21 45871030, jakarta@rehaus.com **IE: Dublin**, +353 1 8165020, dublin@rehaus.com **IN: Mumbai**, +91 22 61485858, mumbai@rehaus.com **New Delhi**, +91 11 45044700, newdelhi@rehaus.com **Bangalore**, +91 80 2222001314, bangalore@rehaus.com **IT: Pesaro**, +39 0721 200611, pesaro@rehaus.com **Roma**, +39 06 90061311, roma@rehaus.com **Treviso**, +39 0422 726511, treviso@rehaus.com **JP: Tokyo**, +81 3 57962102, tokyo@rehaus.com **KR: Seoul**, +82 2 5011656, seoul@rehaus.com **KZ: Almaty**, +7 727 3941301, almaty@rehaus.com **LT: Vilnius**, +370 5 2461400, vilnius@rehaus.com **LV: Riga**, +371 6 7609080, riga@rehaus.com **MA: Casablanca**, +212 522250593, casablanca@rehaus.com **MK: Skopje**, +389 2 2402, skopje@rehaus.com **MX: Celaya**, +52 461 6188000, celaya@rehaus.com **Monterrey**, +52 81 81210130, monterrey@rehaus.com **NL: Nijkerk**, +31 33 2479911, nijkerk@rehaus.com **NO: Oslo**, +47 2 2514150, oslo@rehaus.com **NZ: Auckland**, +64 9 2722264, auckland@rehaus.com **PE: Lima**, +51 1 2261713, lima@rehaus.com **PL: Poznań**, +48 61 8498400, poznan@rehaus.com **PT: Lisboa**, +351 21 8987050, lisboa@rehaus.com **Oporto**, +351 22 94464, oporto@rehaus.com **QA: Qatar**, +974 44101608, qatar@rehaus.com **RO: Bacau**, +40 234 512066, bacau@rehaus.com **Bucuresti**, +40 21 2665180, bucuaresti@rehaus.com **Cluj Napoca**, +40 264 415211, clujnapoca@rehaus.com **RS: Beograd**, +381 11 3770301, beograd@rehaus.com **RU: Chabarowsk**, +7 4212 411218, chabarowsk@rehaus.com **Jekaterinburg**, +7 343 2535305, jekatarinburg@rehaus.com **Krasnodar**, +7 861 2103636, krasnodar@rehaus.com **Nishnij Nowgorod**, +7 831 4678078, nishnijnowgorod@rehaus.com **Nowosibirsk**, +7 3832 000353, nowosibirsk@rehaus.com **Rostow am Don**, +7 8632 978444, rostow@rehaus.com **Samara**, +7 8462 698058, samara@rehaus.com **St. Petersburg**, +7 812 3266207, stpetersburg@rehaus.com **Woronesch**, +7 4732 611858, woronesch@rehaus.com **SE: Örebro**, +46 19 206400, orebro@rehaus.com **SG: Singapore**, +65 63926006, singapore@rehaus.com **SK: Bratislava**, +421 2 68209110, bratislava@rehaus.com **TH: Bangkok**, +66 27635100, bangkok@rehaus.com **TW: Taipei**, +886 2 87803899, taipei@rehaus.com **UA: Dnepropetrowsk**, +380 56 3705028, dnepropetrowsk@rehaus.com **Kiev**, +380 44 4677710, kiev@rehaus.com **Odesa**, +380 48 7800708, odesa@rehaus.com **Lviv**, +380 32 2958920, lviv@rehaus.com **US: Detroit**, +1 248 8489100, detroit@rehaus.com **Grand Rapids**, +1 616 2856867, grandrapids@rehaus.com **Los Angeles**, +1 951 5499017, losangeles@rehaus.com **Minneapolis**, +1 612 2530576, minneapolis@rehaus.com **VN: Ho Chi Minh City**, +84 8 38233030, sales.vietnam@rehaus.com **ZA: Durban**, +27 31 7657447, durban@rehaus.com **Johannesburg**, +27 11 2011300, johannesburg@rehaus.com **Cape Town**, +27 21 9821254, capetown@rehaus.com **East London**, +27 43 7095400, eastlondon@rehaus.com **If there is no sales office in your country**, +49 9131 925888, salesoffice.ibd@rehaus.com

© REHAU AG + Co
Rheniumhaus
95111 Rehaus
www.rehaus.uk

Subject to technical modifications
817611 EN 03.2017