



**IMA SCHELLING**  
GROUP



# Novimat

The Novimat Concept and Systems range for highly efficient production

[imaschelling.com](http://imaschelling.com)



## NOVIMAT R3 | L20

the throughfeed machine for quality, productivity  
and flexibility

All the units of the Novimat are of solid design and have optimal motor power, which ensures excellent repeatability, a high utilization rate and a long life expectancy. The Novimat allows cost-efficient and reliable edgbanding using tape up to 3 mm and lippings up to 20 mm thick.



NOVIMAT  
EN 02/2022



### Energy-efficient production

Protection of the environment and energy efficiency are standard features of the Novimat series: Examples of this include the integrated standby mode, optimized extraction of the processing units, minimal usage of compressed air, and energy-efficient drive technology.



# OVERVIEW



## BASE FRAME

solid and rigid fabricated base frame

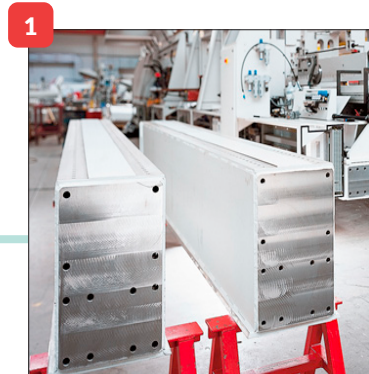

## ICOS OPEN

the ideal controller for single machines and high-performance systems

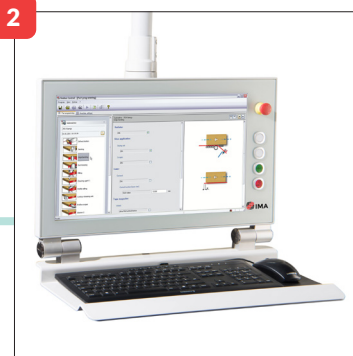

## MACHINE INFEEED

for manual or automated workpiece infeeding



## GLUING AREA

offers various processes for edge banding (also in combination)

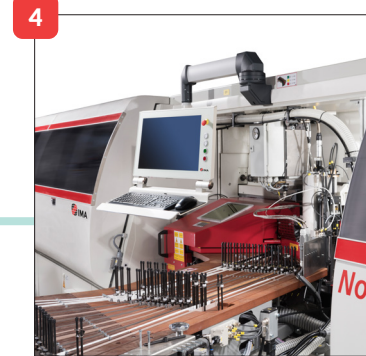

## EDGE MAGAZINE

with up to 24/48-station edges shafts (depending on the range)

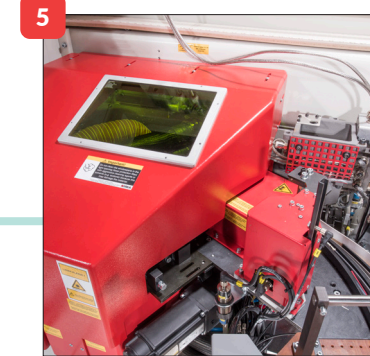

## CONTOUR MILLING UNIT

for a high-quality and aesthetic look for your products

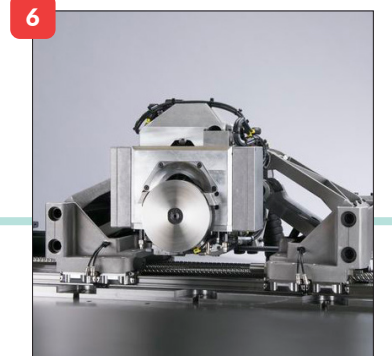





COMPREHENSIVE  
UNIT MODULES  
FOR INDIVIDUAL  
MACHINE EQUIPPING

## DETAILS OF THE RANGE

### Maximum flexibility and quality for a modern variety of materials

Using the single-sided automatic edge processing machine, both roll and strip material can be processed flexibly and to high quality in pass-through. Thanks to a wide variety of units for joining, edge gluing and edge post-processing, the machines of the Novimat range produce perfect results for an aesthetic look and perfect quality of your products.

#### CONTOUR MILLING UNIT (KFA)

- servo/linear system
- processing unit for the leading and trailing edge
- automatic/self-positioning of the milling tool along the profile
- large tracing roller of 140 mm diameter
- direct drive technology and low weight for dynamic performances and high cycle rates
- profile changeovers are possible in between the panel gap
- adaptive parameters for the processing of specific materials (e.g. with regard to lightweight materials, reduction of the tracing force)
- IMA-patent
- up to 4 profiles and chamfers in the outlet

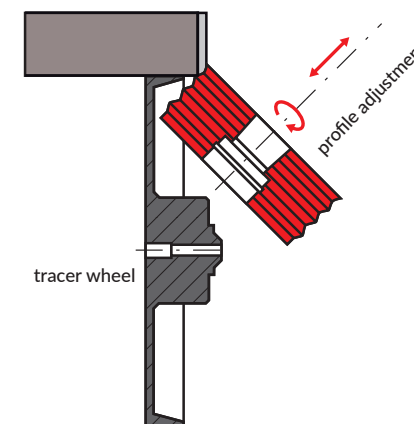

#### CONTOUR TRIMMING UNIT (SKF)

- radius and chamfer milling
- manual positioning of the milling motor for chamfer milling (optional: NC adjustment)
- milling motor with quick-change system for easy setting up for various radii

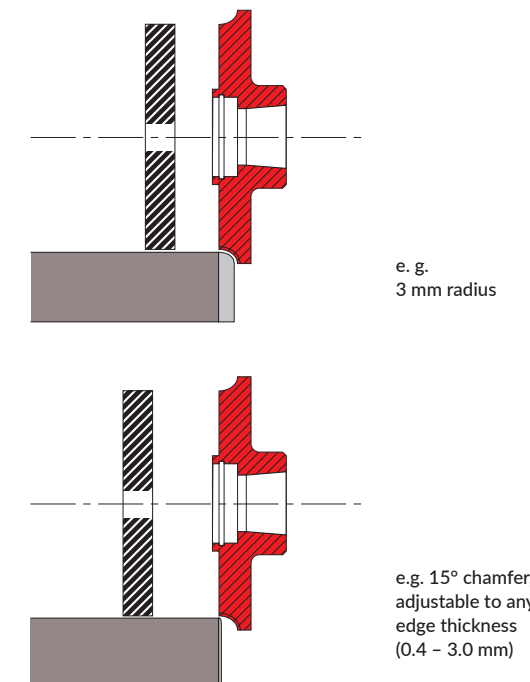



## MACHINING RANGE

### A WORKPIECE FEEDING AND HANDLING

Efficient and precise feeding of workpieces and in panel return conveying systems for one-man operation for optimal structuring of the vicinity of the machine.

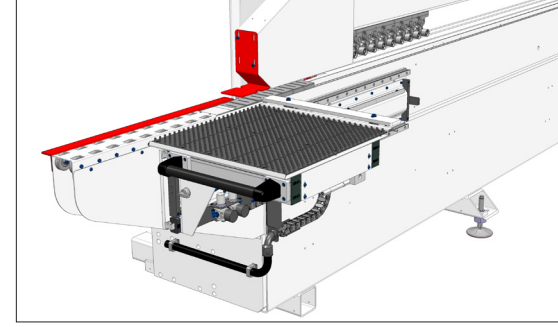

Infeed table small



21.5" wide monitor with touch screen keyboard and mouse operation

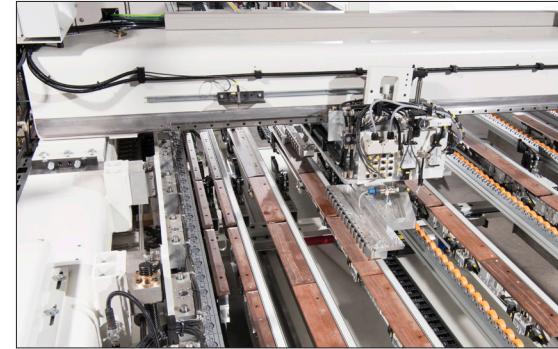

Servo infeed and détente stop system

### 1 JOINING

- two-station, 3-station or 4-station joining matched for perfect joining results with your materials
- tool diameters of 125 or 150 mm possible
- also with hydraulic pickup

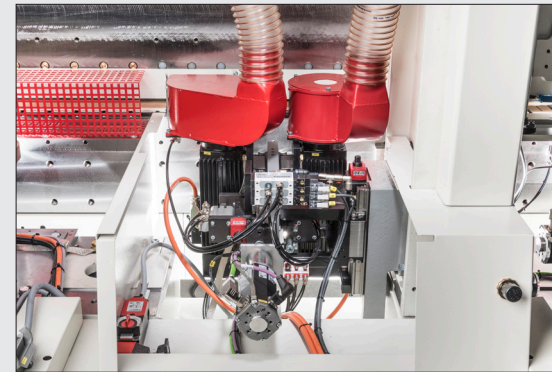

Two-station joint milling

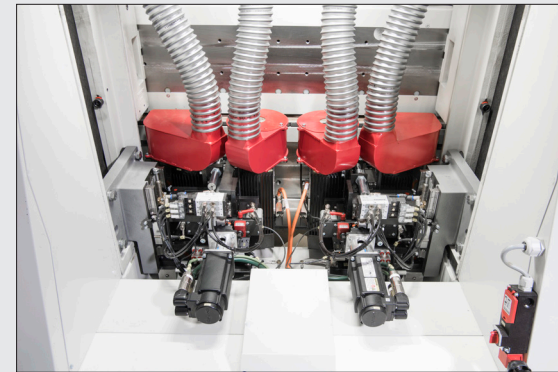

Four-station joint milling

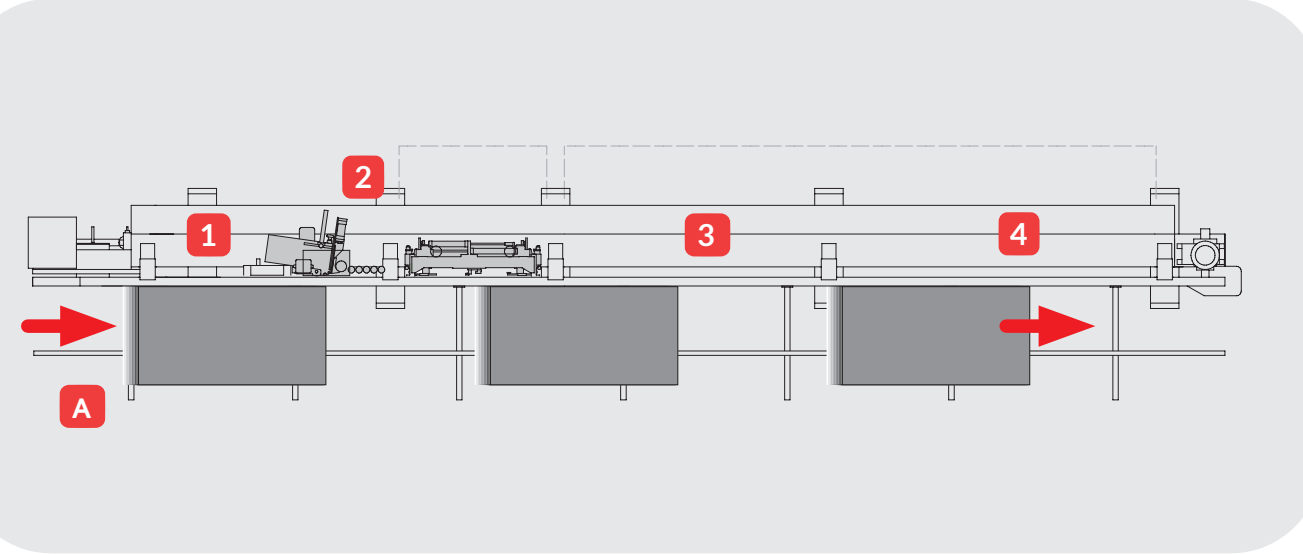

### 2 GLUING AREA

#### Novimat R3

- with quick-lock glue applicator
- for coil material up to 3 mm
- IMALUX, Laser Edging and/or conventional gluing
- melting system for all current melt-type adhesives

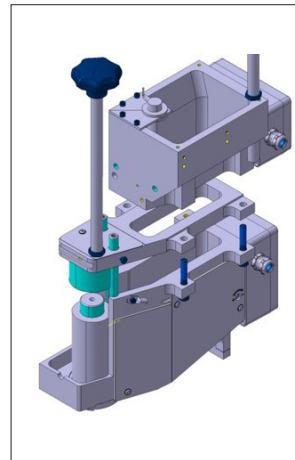

glue applicator with extended cleaning intervals



Edge banding unit with 6-coil magazine

#### Novimat L20

- with Quick-lock glue applicator
- for coil material up to 3 mm and solid wood strips up to 20 mm
- conventional gluing

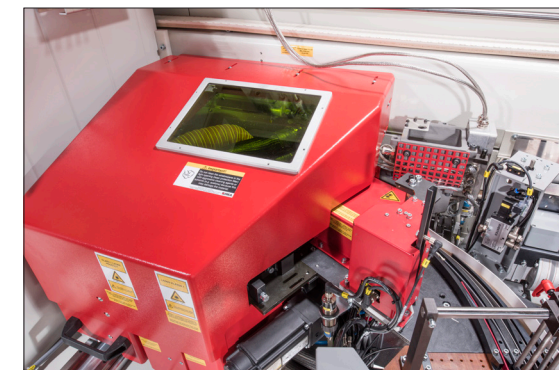

IMALUX laser unit



Laser Edging diode laser

### 3 POST-PROCESSING

#### End trimming, Milling, contour trimming

- end trimming unit for straight and chamfer trimming
- milling unit (pre-milling)
- profile milling unit or multi-profile milling unit
- contour milling unit (KFA)
- contour trimming unit (SKF)

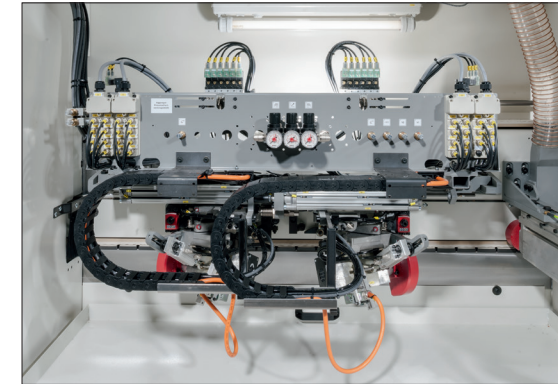

End trimming unit

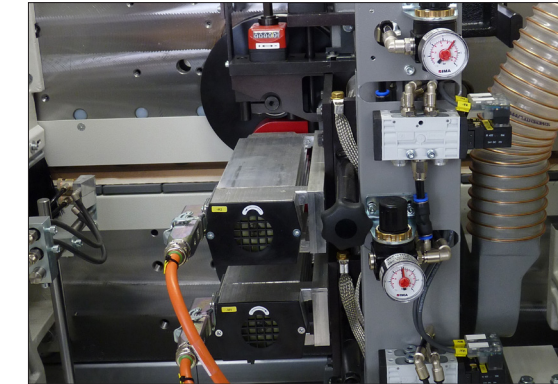

Pre-/flush milling unit

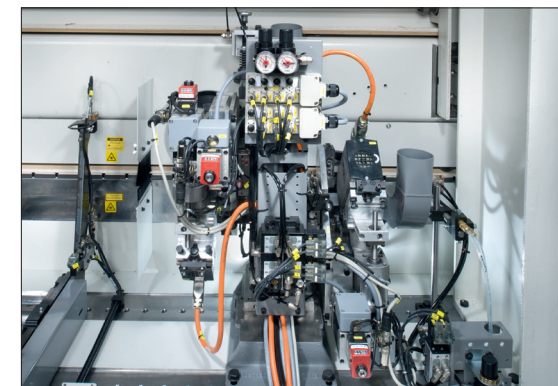

Multi-profile milling unit



Contour milling unit KFA x20

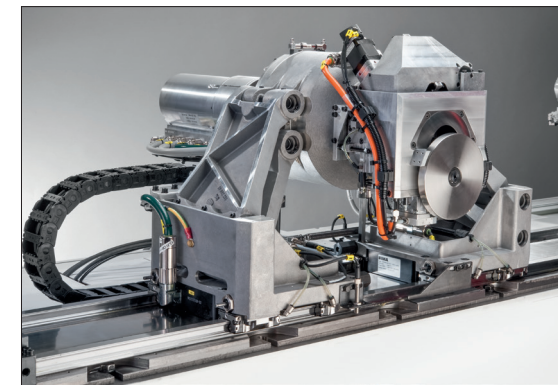

Contour milling unit KFA x30

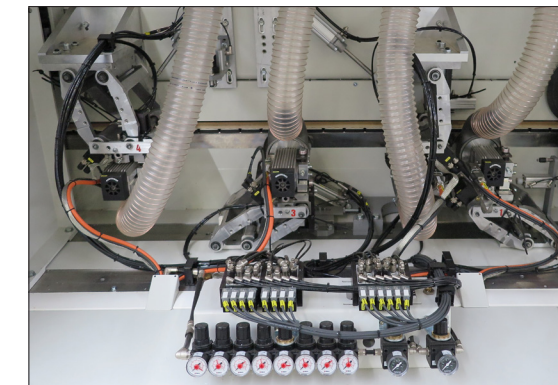

Contour trimming unit (SKF)

### 4 FINE-FINISH AND GROOVING

#### planing, buffing, milling

- profile scraper or Multi-profile scraper unit
- flat scraper unit
- buffing unit oscillating
- corner buffing unit
- buffing unit with 2 or 4 motors
- smoothing unit
- grooving unit
- sanding unit
- profile sanding units (top + bottom)

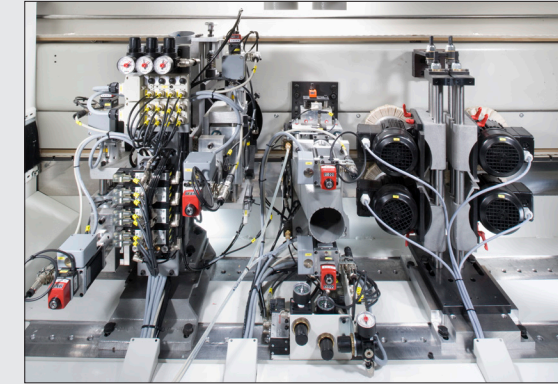

Multi-profile scraper unit  
Flat scraper unit  
Buffing unit with 4 motors

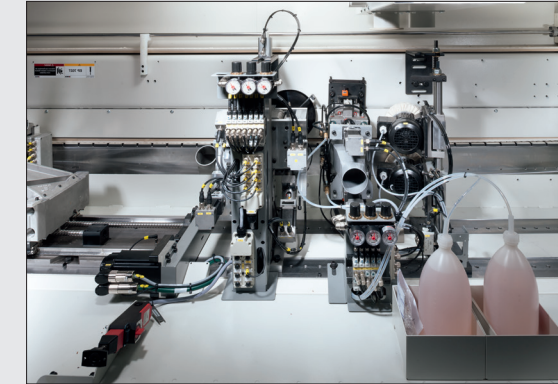

Multi-profile scraper unit  
Flat scraper unit  
Buffing unit with 2 motors

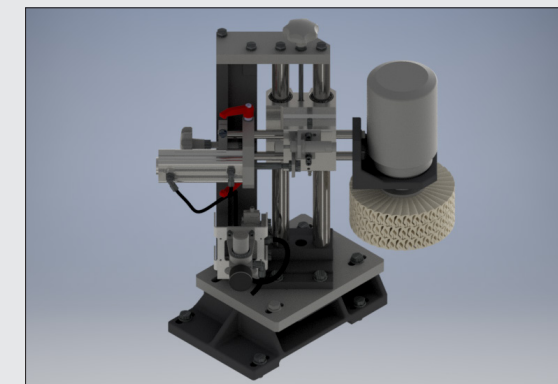

Corner buffing unit

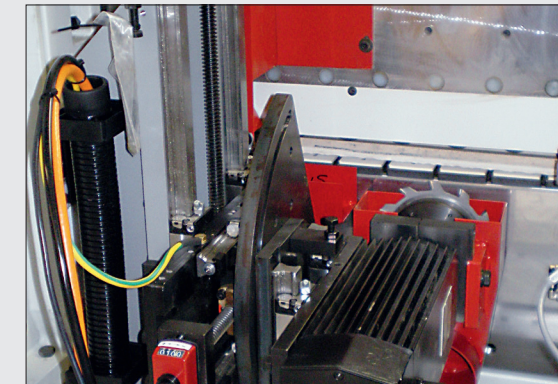

Grooving unit



# INTEGRATION OPPORTUNITIES

Depending on the production work flow and degree of automation of your production, the machines of the Novimat Concept or Systems range can be equipped both with infeed systems and panel return systems. Operation is thus made easier and more efficient. It is also possible to directly connect the machines to the upstream and downstream process steps with no problems.



## FEEDBACK SERIES

Work piece return feed systems in many configurations for various sizes of work pieces and cycle times.

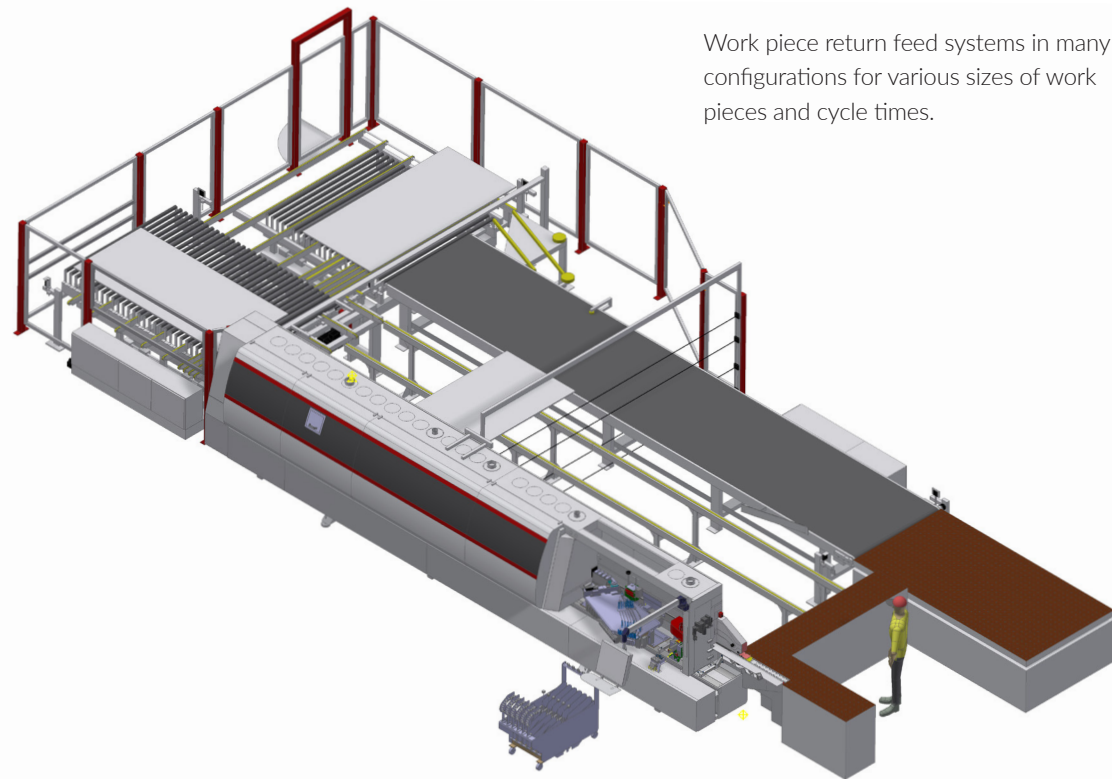

## PERFORMANCE.ONE SOLUTIONS

partially automated solution for efficient batch size 1 production

- modular, future-proof machine concept of IMA Schelling panel sizing and edge processing machines
- modern production technology with simple operation
- high quality production with proven IMA Schelling unit technology
- training options for your operators to ensure efficient production





## ICOS OPEN - HIGHEST EASE OF USE

The ICOS Open PC-controller guarantees the highest performance concerning the optimization of productivity results. The controller guarantees the perfect information flow between operator and machine therefore providing optimal conditions for a smooth production process. The ICOS Open operator system combines the control functionality for the machine and the individual working units. The clearly laid out screen menu is accomplished by icons. The individual processing steps are visually displayed in pictograms. Current machine data (i.e. optimum glue temperature) is imported into the icons.

### ICOS OPEN OVERVIEW

- modern 21,5" wide-screen machine controller
- touch, keyboard or mouse
- Windows® operating system
- two hard drives for additional peace of mind
- uninterrupted Power Supply
- job list function
- program management for main- and sub-programs
- tooling and edgeband data management
- error display in clear text
- MDE
- prepared for tele-service (controls prepared for later addition of IMA Service Portal)

### OPTIONAL

- bar code control
- IMA Maintenance Manager
- IMA Serviceportal
- Remote service via IMA Service Portal with the following functionality
  - service ticket
  - remote diagnostics
- and much more

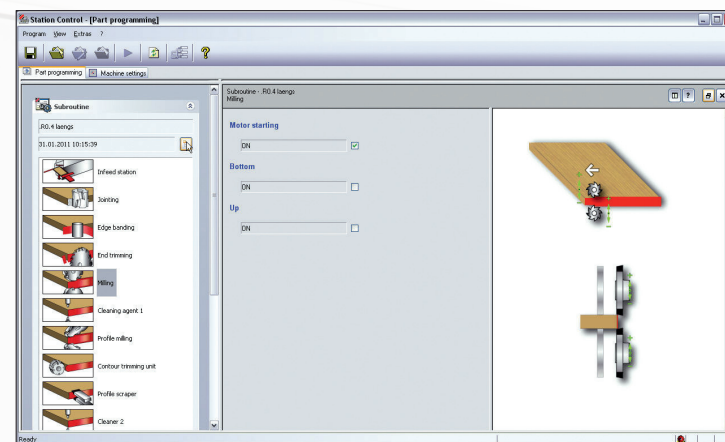





## SERVICE PLATFORM ZIMBA

ZIMBA is an Industrial Internet of Things (IIoT) data collection software and service portal that gives you valuable information and specific recommendations for maximizing efficiency and machine performance. ZIMBA helps achieving the highest productivity of IMA Schelling products throughout their lifecycle.

**ZIMBA**  
MACHINES, HOW ARE YOU?

### ZIMBA ASSISTANCE APP

IMA Schelling stands for innovative and customized solutions providing the highest quality. It requires high quality support all the way from planning stage through engineering and software to assembly, start-up and aftersales services.

The ZIMBA Assistance App connects employees on site with in-house experts in an interactive video conference. That in turn enables us to provide customers with a fast and simple solution.



### ZIMBA TICKET APP

Professional, simple and fast. The ZIMBA Ticket App supports you with any tasks regarding your machines.

The App has been designed for the IMA Schelling service portal in order to have access to machine documents, our ticket and support system as well as maintenance management .





# TECHNICAL DATA

	R3	L20
<b>MACHINE</b>		
Track speed [m/min] (the max. track speed rate depends on the end trimming and contour trimming units)	6 - 30 m/min.	
Fixed panel overhang from the chain track (including the edging)	38 mm	38 mm (with edging thickness 0,3 - 8 mm)
<b>WORKPIECE</b>		
Panel thickness	min. 8 mm max. 60 mm	
Panel length	min. 150 mm	
Panel width	min. 65 mm	min. 65 mm (with edging thickness 0,4 - 3 mm)
<b>EDGE TAPE</b>		
Tape height	min. 14 mm max. 65 mm	
Tape thickness	min. 0,4 mm max. 3 mm	min. 0,4 mm max. 20 mm
<b>POWER SUPPLY + COMPRESSED AIR SUPPLY</b>		
Power supply	3 / N, 400 V +5/ -10 % 50 Hz	
Control voltage	24 V	
Compressed air	7 bar	

## EDGING MATERIAL: COILS

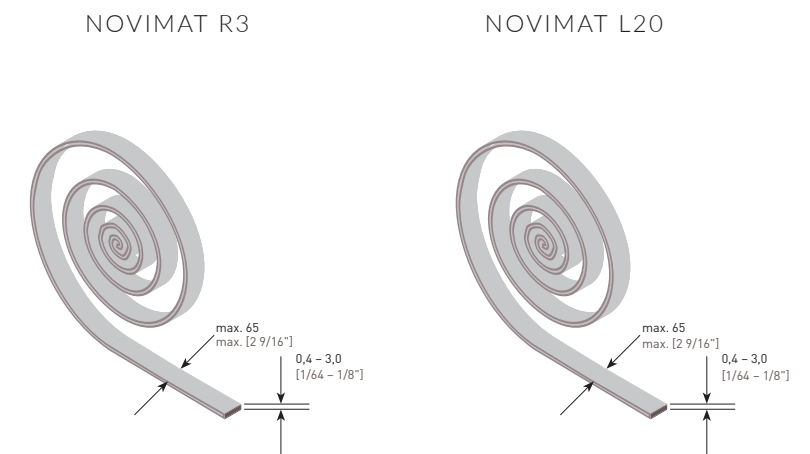

## EDGING MATERIAL: SOLID WOOD LIPPINGS

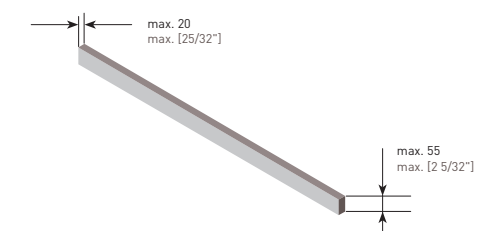

## SMALLEST PANEL (LENGTH WISE PROCESSING):

All dimensions in mm [inch].

All equipment offered is made to metric standards. Dimensions shown in English measure are approximate and for comparison purposes only.

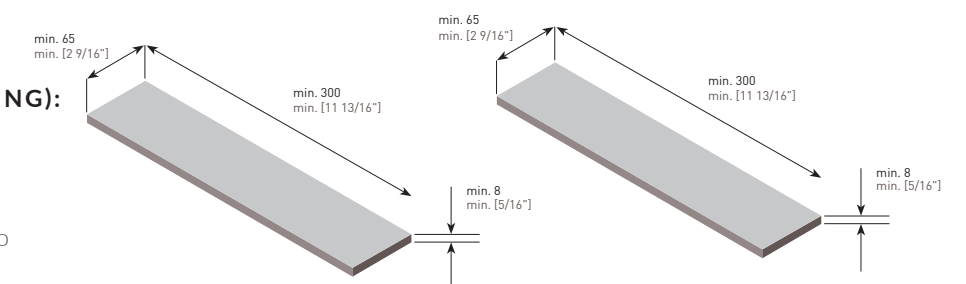



The IMA Schelling Group is a reliable partner for implementing of sophisticated system solutions.  
The demands of our customers are a daily challenge to us, our know-how  
and creativity! We work with you to develop innovative and unique solutions for wood processing.

[www.imaschelling.com](http://www.imaschelling.com)

Modifications and mistakes reserved. Illustrations are approximate. Subject to technical modifications and mendments and to further developments. The offer, respectively the order confirmation is relevant in either case! The picture of the machine could have been taken without complete protection devices.  
The protection device is part of the scope of delivery. Photos could also be options, not being part of the scope of delivery and are not binding in detail.



**IMA SCHELLING**  
GROUP