



Engineering progress
Enhancing lives

REHAU EDGE™

Technical Information



Contents

01 Information and safety advice	4
02 Component overview	6
03 Pipes and fittings	8
04 Installation tools	10
05 Making the EDGE™ connection	12
06 Installation guidelines - General	15
07 System Protection	28
08 Design and operating guidelines	33
09 Pressure testing and commissioning	37
10 Fire safety	40
11 Pressure loss tables	41



This Technical Information **REHAU EDGE™**
- is valid from **January 2023**.

The latest version of this Technical Information can be found at
<https://www.myrehau.com/buildingsolutions/library>

This documentation is copyright protected. The rights of translation, reproduction, drawing of illustrations, broadcasting, and rendering on photomechanical or by similar means as well as the storage in data processing systems, are reserved.

All measurements and weights are of approximate values.
Errors and changes are to be expected.

For further information on the EDGE™ system, please scan the below QR code.



<http://qr.rehau.com/d3c5181a9a>

01. Information and safety advice

Notes on this Technical Information

Validity

This Technical Information is valid for Australia.

Definitions

- **Supply lines or piping** consist of pipes and their joints (e.g. compression sleeves, fittings, threads, or similar). This applies to all pipes in this Technical Information.
- **Piping systems, installations, systems, etc.** consist of the pipes and the necessary components.
- **Connection components** consist of EDGE™ fittings (including pre-assembled components – Clip and inner sleeves) with the corresponding compression sleeves and pipes as well as seals and screw connections.
- **EDGE™ connection** – means a REHAU compression sleeve connection to form a seal between an EDGE™ fitting and EDGE™ pipe
- **EDGE™ fitting** – means REHAU EDGE™ fittings made of engineered polymer or DZR brass with at least one EDGE™ connection (e.g. coupler, elbow, T-piece, adapter, union connector etc)
- **EDGE™ pipe or EDGE™ PE-Xa pipe** – means REHAU EDGE™ pipe SDR 9 made of PE-Xa (silver, red, green and lilac)
- **Pipe support channel** – means REHAU's zinc plated clip-on channel to limit thermal length changes and pipe sagging in EDGE™ pipes

Explanation of symbols



Safety information



Legal information



Important information, which needs to be taken into account



Information on the Internet



Your benefits/advantages

Safety advice and operating instructions

- Please read these safety instructions and technical information carefully and completely for your own safety and other's before beginning the installations.
- If you have any questions or need further clarifications
- on the safety instructions and/or the individual installation instructions, please discuss with REHAU
- **Failure to observe the safety information/instructions can result in damage to property and persons.**

Intended use

The REHAU EDGE™ piping system components and compression sleeve jointing technique is considered as propriety systems and shall be designed, installed and operated in accordance to REHAU's Technical Information. REHAU EDGE™ piping system shall only be used for the following applications:

- EDGE™ silver pipes - hot and cold water supply
- EDGE™ red pipes - hot water supply
- EDGE™ green pipes - rainwater plumbing
- EDGE™ lilac pipes - recycled water plumbing

Any other use that does not fall within the intended use of the system is prohibited.

Further, REHAU EDGE™ piping system shall be operated with the operating parameters set forth in this Technical Information. Not adhering to the operating parameters will void the REHAU warranty.

Piping network calculation

In addition to the information contained in this technical document, various services are offered for the sizing of drinking water and heating systems by REHAU. For extensive advice, please consult your REHAU sales office



When installing this pipe system, please observe all applicable national and international regulations on installation, accident prevention and safety together with the information contained in this Manual.

Also observe the applicable laws, standards, guidelines and regulations (e.g. DIN, EN, ISO, NCC, NZBC, AS/NZS) as well as regulations on environmental protection, provisions of professional associations and regulations of the local public utility companies.

Any applications not described in this Manual - i.e. Non-standard applications - must be discussed with our Technical Applications Department. For more detailed advice, please contact your REHAU Sales Office.

This design and installation information is related solely to the specific REHAU product. Occasionally, references are made to parts of applicable standards and directives. Always observe the current version of any guidelines, standards or directives.

Further standards, directives and guidelines related to the design, installation and operation of drinking water, heating or buildings services systems should also be referred to, but these do not form part of this Technical Information.



General safety measures

- Keep your workplace tidy and free of obstructions.
- Ensure there is always sufficient light.
- Keep children, pets and unauthorised persons away from tools and installation areas. This is especially important when carrying out refurbishment/repair work in occupied areas.
- Only use the corresponding components in the piping system that have been generally approved by REHAU. Using components which are not part of the system or tools which do not originate from the respective REHAU installation system can lead to accidents or other hazards.

Fire protection

Pay particular attention to the applicable fire protection regulations and the correspondingly valid building regulations/ regional building regulations/ building codes, especially when:

- penetrating through ceilings and walls
- working in areas with specific requirements of preventative fire protection measures (observe national regulations)

Trades qualifications

- Only authorised and trained persons are allowed to install REHAU systems.

Work clothing

- Wear eye protection, adequate work clothing, protective shoes, and a hairnet if you have long hair.
- Do not wear loose clothing or jewellery as these can be caught by moving parts.
- A safety helmet must be worn especially when carrying out installation work at face level or overhead.

Follow the installation instructions





- Read carefully and observe at all times the Operating Manual for the REHAU installation tool which is being used.
- Incorrect handling of tools can cause cuts, crush or sever limbs.
- Incorrect handling of tools can damage jointing components and cause leaks.
- The REHAU pipe cutters have a sharp blade. Store and handle them in such a way that the REHAU pipe cutters will not create any risk of injury.
- When cutting the pipe to the desired length, keep a safe distance between the holding hand and the tool (pipe cutter).
- When cutting, do not reach into the cutting zone of the tool or near its moving parts.
- Keep your hands away from movable parts or the tools pressing area during jointing.
- Before the joint is completed, the fitting may fall out of the pipe. This is an injury hazard.

Operating parameters

- If the operating parameters are exceeded, the pipes and joints may become overstrained. Not adhering to the operating parameters is thus not allowable.
- Keeping within the operating parameters must be ensured by safety control equipment (e.g. pressure reducers, safety valves, etc.)

02. Component overview

2.1 System components

	Size 16 – 25	Size 32
Pipes	 <p>EDGE silver (hot and cold water)</p> <p>EDGE red (hot water)</p> <p>EDGE green (rain water)</p> <p>EDGE lilac (recycled water)</p>	
Compression sleeves	 <p>Material: Engineered polymer, Colour: Black, Characteristics: Identical ends, protruding ribs</p>	
Polymer fittings	 <p>Material: Engineered polymer Colour: Black, Connection Type: Threadless</p>	
Brass fittings	 <p>Material: DZR brass, Colour: Brass, Connection type: Threadless, Screwing , Compressing</p>	
RAUTOOLS	<p>Manual and battery operated compression tools and pipe cutters. Refer to Chapter 4.</p>	

2.2 System Identification

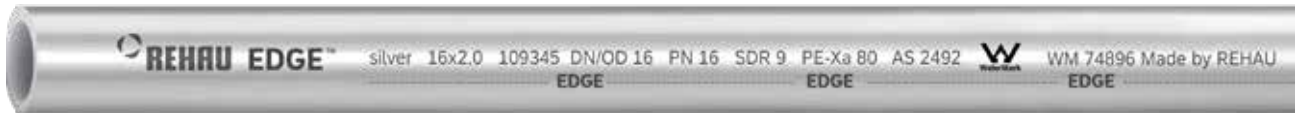

EDGE™ pipes are clearly identified by their marking. All pipes bear a print line as shown above with the word EDGE™ repeated at regular intervals. The print lines on EDGE™ pipes are black, whereas RAUTITAN pipes print lines are white. In addition, compared to the REHAU RAUTITAN Pipes, the standard EDGE™ hot and cold water pipe is silver as opposed to platinum.



EDGE™ Sleeve with protruding ribs



RAUTITAN PX Sleeve with smooth surface.

EDGE™ sleeves are similar in appearance to the RAUTITAN System's PX Sleeves however they have protruding ribs on the sleeve outer surface in the direction of flow and are also slightly shorter in length.

i **EDGE™ and RAUTITAN PX Sleeves are not interchangeable and shall only be used for their respective systems.**

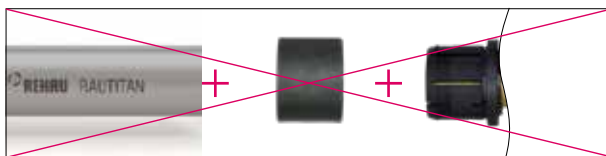

i EDGE™ fittings and sleeves are only compatible with EDGE™ Pipe and must not be used with other systems, including other REHAU systems.

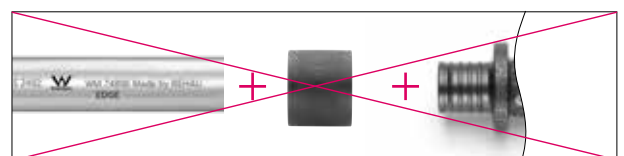

EDGE™ pipe must not be used with RAUTITAN fittings.

03. Pipes and fittings

3.1 PE-X materials

- ✓ - Corrosion resistance of the pipes: No pitting
- No tendency for deposits
- Polymer pipe material reduces sound transmission along the pipe
- Good resistance to abrasion
- All EDGE™ pipes with WaterMark registration comply with AS/NZS 4020 (Components in contact with potable water)

Peroxide-crosslinked polyethylene

Peroxide-crosslinked polyethylene is designated PE-Xa. Individual polyethylene molecules are cross-linked to form a three-dimensional network, under high temperature and pressure with the aid of peroxides. **This method ensures an even and very high degree of crosslinking over the entire cross-section of even, thick-walled, flexible and kink resistant pipes.**

3.2 Technical data of pipes

	Pipe dimensions			
	16	20	25	32
Volume l/m	0.113	0.186	0.295	0.482
Pipe weight, empty (kg/m)	0.091	0.131	0.198	0.317

Tab. 3-1 Technical data of pipes

Technical data	Unit	Hot and cold water pipe		Hot water pipe		Rainwater pipe		Recycled water pipe	
		EDGE Silver		EDGE Red		EDGE Green		EDGE Lilac	
Material	-	PE-Xa		PE-Xa		PE-Xa		PE-Xa	
Surface colour	-	Silver		Dark red		Green		Lilac	
Operating pressure (maximum)	[bar]	10	8	10	8	10	8	10	8
	[kPa]	1000	800	1000	800	1000	800	1000	800
Operating temperature (ISO 15875 classes 1,2) Refer to Section 8.3 for installation in ring mains	[°C]	60	70	60	70	60	70	60	70
Short-term maximum temperature (malfunction)	[°C]	95		95		95		95	
Maximum/minimum installation temperature	[°C]	+50 / -5		+50 / -5		+50 / -5		+50 / -5	
Pipe roughness	[mm]	0.007		0.007		0.007		0.007	
Available sizes	[mm]	[ID]		[ID]		[ID]		[ID]	
		16 x 2.0	12	16 x 2.0	12	16 x 2.0	12	16 x 2.0	12
		20 x 2.3	15.4	20 x 2.3	15.4	20 x 2.3	15.4	20 x 2.3	15.4
		25 x 2.8	19.4	25 x 2.8	19.4	25 x 2.8	19.4	25 x 2.8	19.4
		32 x 3.6	24.8						
EDGE™ system appraisals and certificates		WaterMark to AS 2492, AS/NZS 2537, AS/NZS 4020, AS 2345, ISO 15875 Class 1 / 10 bar and Class 2 / 8 bar (further compliance certificates available on request)							

Tab. 3-2 Technical data of pipes (approximate values)



Pipes can be subjected to maximum operating temperature or maximum operating pressure, but not both.

3.2 EDGE™ fitting components



- All fittings and compression sleeves for EDGE™ can be used for water services.
- Do not combine EDGE™ fittings or compression sleeves with components from other ranges.
- Please note the dimensions of the fittings and compression sleeves.
- The inner sleeve is removable by design, and can be clipped back into place.

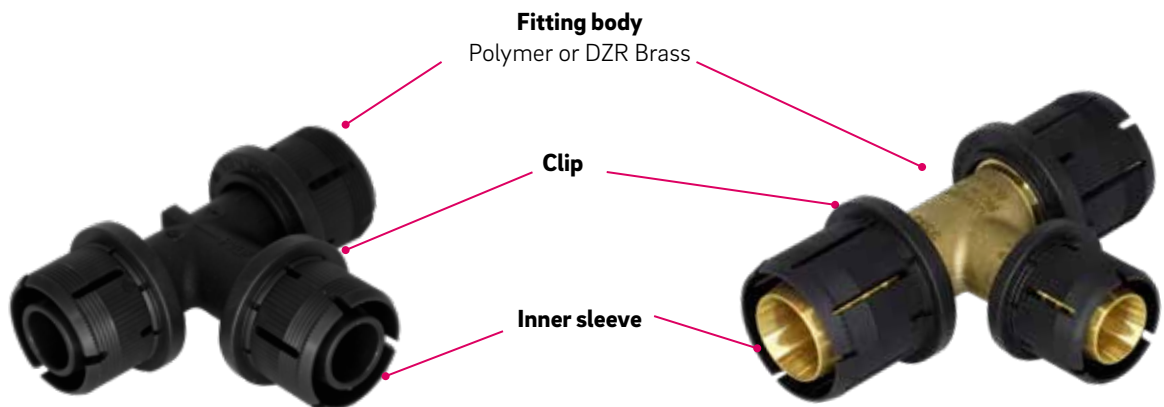

All elements pictured are supplied pre-assembled

Dezincification resistance

Under the effects of certain types of drinking water, a particular form of corrosion known as dezincification can occur in standard brass alloys, e.g. free-cutting brass.

EDGE™ brass fittings are made of special dezincification-resistant brass and are tested for drinking water installation according to ISO 6509 and AS 2345.

04 Installation tools



Before using tools, read and observe the information in the operating instructions completely. If these operating instructions are no longer present with the tool or are no longer available, order a copy or download them from the internet. Do not use damaged tools or partially functioning tools; send these for repair to your local distribution network. Tool servicing needs to be carried out at the specified time to ensure reliable tool performance.



Operating instructions can be downloaded online from www.rehau.com.au or www.rehau.co.nz.

4.1 Compression sleeve tools: RAUTOOL

For EDGE™ system

4.1.1 RAUTOOL L1



Fig. 4-1 RAUTOOL L1

- Manual tool
- Able to compress sizes 16-32mm



When using L1 tool, use only compression jaws that are specifically approved for EDGE™ Sleeves and Fittings (black colour). Refer to Figure 4-4.

4.1.2 RAUTOOLA-light2



Fig. 4-2 RAUTOOL A-light2

- Battery-operated hydraulic tool
- Able to compress sizes 16-32mm
- Drive with battery-operated hydraulic unit located directly at the tool cylinder



When using A-Light2 tool, use only compression jaws that are specifically approved for EDGE™ Sleeves and Fittings (black colour).

4.1.3 RAUTOOLA3



Fig. 4-3 RAUTOOLA3

- Battery-operated hydraulic tool
- Able to compress sizes 16-32mm
- Drive with battery-operated hydraulic unit



When using A3 tool, use only compression jaws that are specifically approved for EDGE™ Sleeves and Fittings (black colour).

4.1.4 Rothenberger Romax Axial

EDGE™ connections can be made using the Rothenberger Romax Axial tool in combination with EDGE™ jaws ALight2 in black colour



Fig. 4-4 Rothenberger Romax Axial

4.1.5 EDGE™ Jaws



Fig. 4-5 EDGE™ jaws suitable for RAUTOOL L1



Fig. 4-6 EDGE™ Dual jaws suitable for RAUTOOL A-Light 2 and Rothenberger Romax Axial tool

4.2 Pipe cutters

When cutting EDGE™ pipes, observe the following:

- Cut the pipe square and without burrs.
- Pipe cutters must be in good working condition.

Approved pipe cutters for EDGE™ pipe:

		Pipe Dimensions			
		16	20	25	32
Hot and cold water pipe	EDGE Silver				
Hot water pipe	EDGE Red				
Rainwater pipe	EDGE Green				
Recycled water pipe	EDGE Lilac				

Pipe cutters:

Pipe cutter	Image	16	20	25	32
Pipe cutter 16/20 (stabil)		✓	✓	✗	✗
Pipe cutter 25		✓	✓	✓	✗
Pipe cutter 40		✓	✓	✓	✓
Rothenberger Rocut TC32		✓	✓	✓	✓

Tab. 4-1 Approved pipe cutters for EDGE™ pipe

05 Making the EDGE™ connection

5.1 EDGE™ Installation Steps – General overview



1 Push the sleeve over the pipe

- ✓ EDGE™ compression sleeves can be fitted from both sides



2 Insert pipe into the fitting and push fully home

- ⚠ Check the inspection window on the inner sleeve to ensure the pipe is visible inside.



3 Make the compression



4 Fully compressed joint

- ✓
 - Permanently sealed joint
 - Without O-ring (self-sealing pipe material)
 - Easy visual inspection
 - Can be immediately pressurized
 - Pipe doesn't need to be calibrated or deburred
 - Robust jointing technology, highly suitable for construction sites
 - Connection leaks when not compressed
 - Compression can be carried out with water inside, but must be pressure-less

- ⚠ Only make connections using RAUTOOL. Please observe the Technical Information and the corresponding operating instructions and instruction leaflets for information on handling the tools and making connections. Do not use dirty or damaged connection components or tools. The range of connection components can be found in the latest product book.

Installation temperature

- Minimum installation temperature is -5 °C.
- Maximum installation temperature is +50 °C.

For maximum operation temperature refer to Chapter 8.

5.2 Cutting the pipe

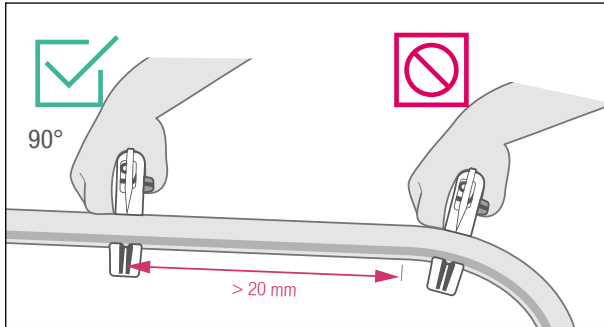

Fig. 5-1 Cut the pipe at 90° and without burrs

1. Prior to cutting the pipe ensure the cut length accounts for the insertion depth of the pipe into the EDGE™ Fitting (Approximately 1 sleeve length).
2. Select the appropriate pipe cutter (refer to Tab 4-1).
3. Cut the pipe at 90° and without burrs.



- Check the blade of the pipe cutters regularly for damage and replace the blade or the cutters as necessary.
- If the pipe was cut improperly, re-cut the pipe to ensure a square and burr-free cut.

5.3 Sliding the EDGE™ sleeve onto the pipe

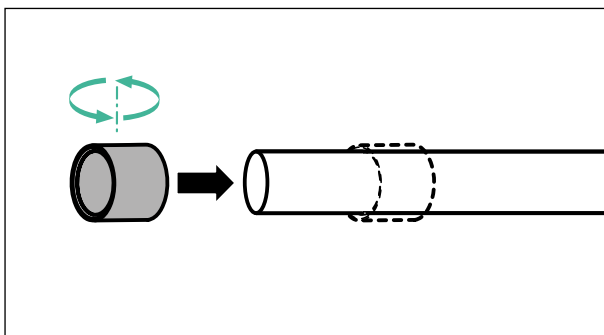
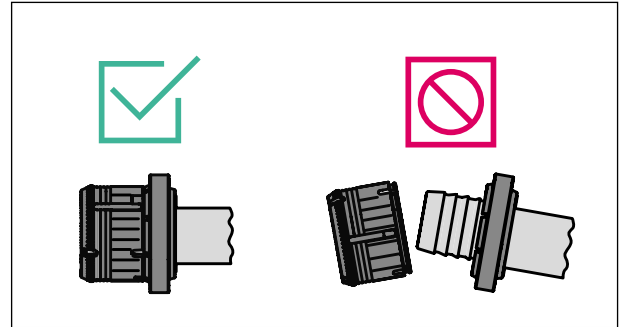

Fig. 5-2 Sliding EDGE™ sleeves onto the pipe

EDGE™ Sleeves are reversible and can be put onto the pipe in either direction.

5.4 Checking the Fittings



Check that the inner sleeve is in the correct position. If necessary, re-insert the loose inner sleeve onto the clip.

- Note the direction of insertion: Inner sleeve groove facing the clip, chamfer on the other side.
- Push the inner sleeve back onto the clip by hand.
- Check the correct position of the inner sleeve: Hold the clip and turn the inner sleeve at the same time. The inner sleeve shall be easy to turn and shall be fully assembled before making the joint.

Check the entire fitting to ensure there is no damage. Replace the fitting if the barb, or any other component, is damaged.

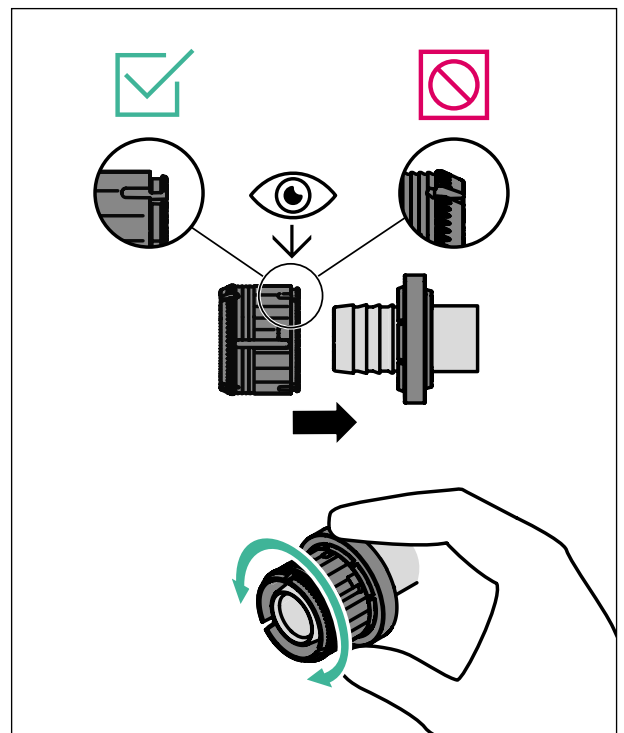

5.5 Inserting the pipe

Insert the pipe into the fitting and push until it is fully home. There should be a slight resistance when inserting the pipe.

After insertion, check the correct insertion depth via the inspection windows. Make sure the inspection window is completely filled by the pipe.

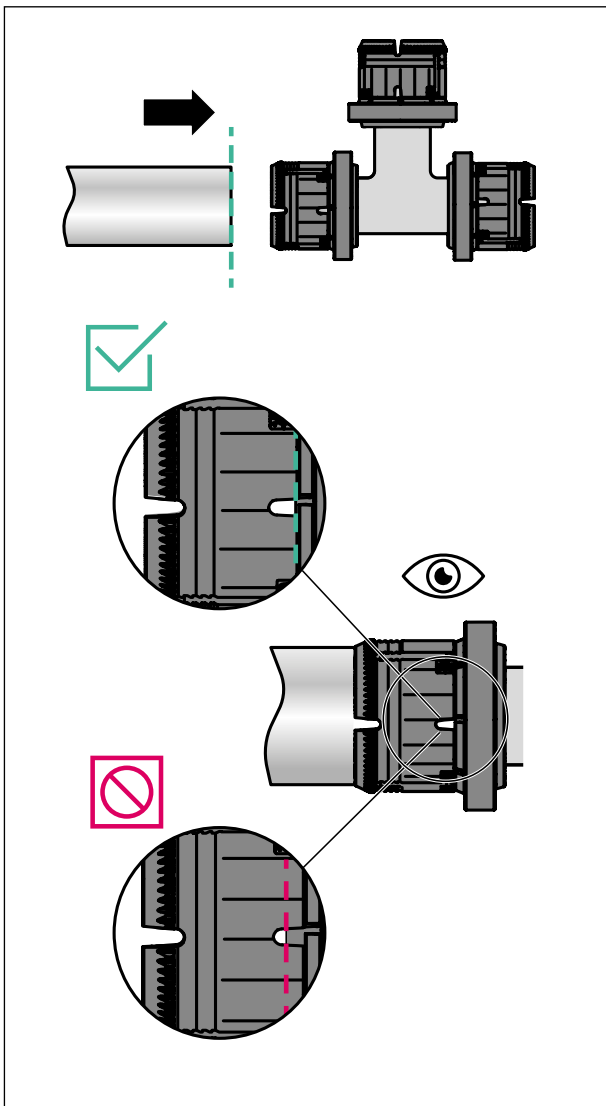

5.6 Compressing the joint

Push the compression sleeve towards the inner sleeve far enough that you are able to place the jaws on the outside edge of the sleeve and the outside edge of the clip.

Place the tool jaws over the pipe, so that it is in firm contact with the pipe and fitting body, as well as the outer edge of the sleeve and outer edge of the clip.

Double check the insertion depth of the pipe through the inspection windows prior to compression.

Compress the joint.

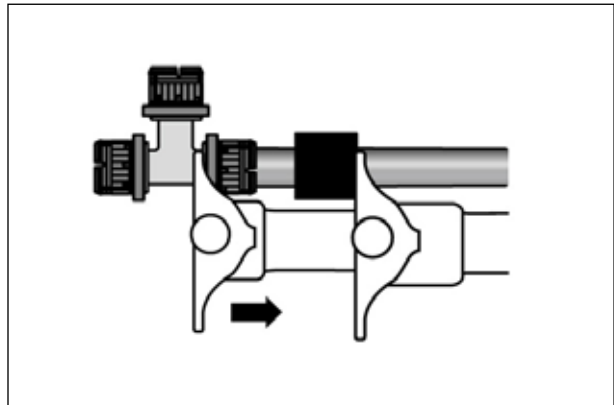

Joint before compression

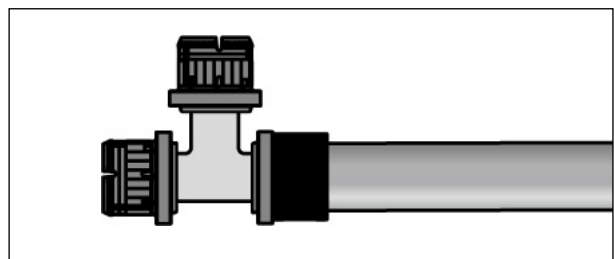

Joint after compression

06 Installation guidelines – general

6.1 Reusing jointing components

EDGE™ fittings and sleeves are not reusable and must not be detached for the purpose of reinstallation. Dispose of all compressed jointing components after installation has been attempted.

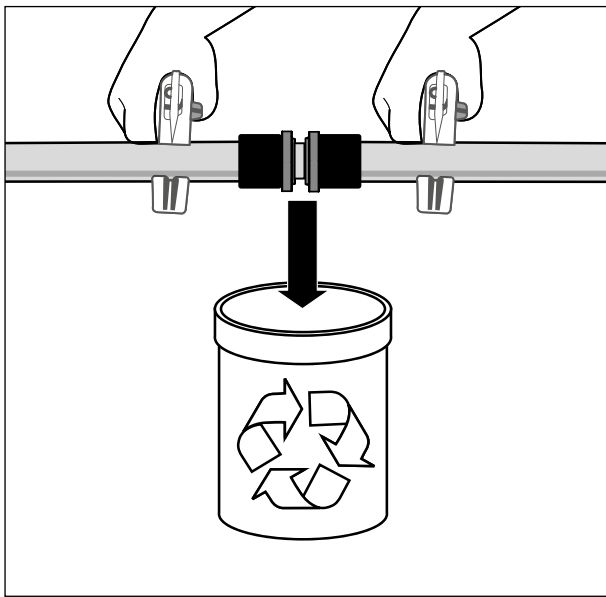

6.2 Installing threaded fittings

General installation requirements

- Avoid over-tightening threaded joints.
- Only use sealants approved for water installation.
- Do not apply excessive hemp to threaded joints. The thread tips must be visible.
- Use open-end wrenches in the right size. Do not clamp fitting too tightly into the vice.
- Do not extend the leverage of installation tools, e.g. with pipes

Compatibility of different thread types

- Only the following thread types may be used with the REHAU EDGE™ system:

Sealing threads in accordance with ISO 7-1 (AS 1722.1) and EN 10226-1:

- Rp = cylindrical female thread
- R = tapered male thread

Fastening pipe threads in accordance with ISO 228 (AS 1722.2):

- G = cylindrical thread, non-sealing in thread

- Check compatibility of different thread types before screwing them together, e.g. tolerances, free movement.
- Only use an appropriate G male connector with flat sealing thread fittings with G female thread.
- If using long threads, ensure the maximum possible screwing depth and sufficient thread depth in opposing parts with inside threads.

6.3 Transition to other pipe materials



Fig. 6-1 EDGE™ copper adapter for transitions to copper pipes AS 1432



Brazing connections

Do not perform brazing on or near the transition adapter of EDGE™.

If repair works or piping network extensions include a change from an existing system to EDGE™ system (or vice versa), threaded joints or connection barbs must be used as clear division between the different systems and to maintain warranty.

6.3.1 Transition to copper system

For transitions from EDGE™ system to copper pipes, use EDGE™ copper adapters. The spigot end of EDGE™ copper adapters is the same size as copper pipes that comply with AS 1432. They can be joined using an additional copper crimp fitting (ie. coupler, elbow or T-piece) as an interim connection.

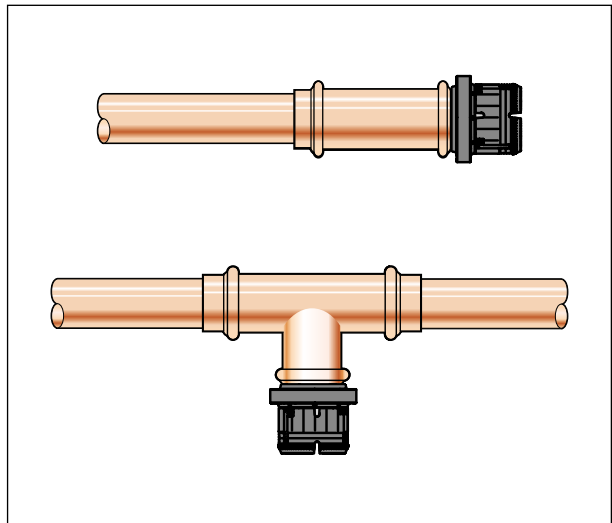

Fig. 6-2 Adapter with a copper interim piece

- REHAU does not approve using EDGE™ copper adapter as a direct transition piece to EDGE™ PE-Xa pipe from any other pipe material (Fig 6-3).
- Do not braze/solder the EDGE™ copper adapter to copper pipe.
- Keep EDGE™ copper adapter away from flames and heat.

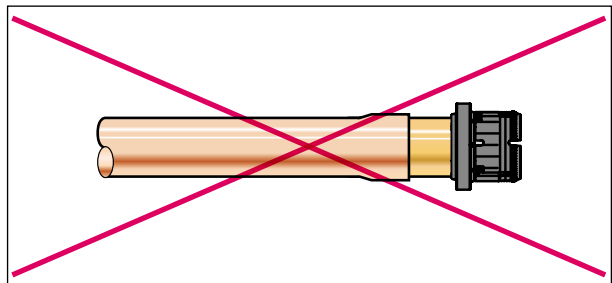

Fig. 6-3

6.3.2 Transition to stainless steel system

There is a great difference in strength between stainless steel and dezincification-resistant brass.



- Direct transition between EDGE™ system and stainless steel installation systems may cause leaks or damage to fittings
- Only connect EDGE™ system to other systems made of stainless steel by interconnecting fittings with a high wall thickness. (e.g. flush-mounted valves or water meters).

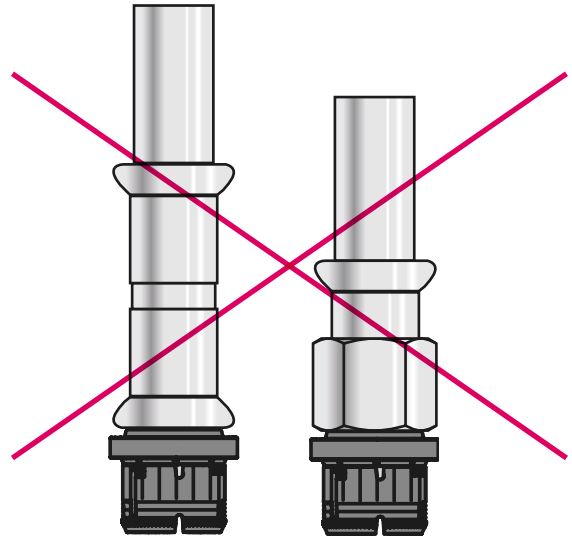

Fig.6-4 Do not connect stainless steel system directly to EDGE™ threaded adapter or EDGE™ copper transition adapter.

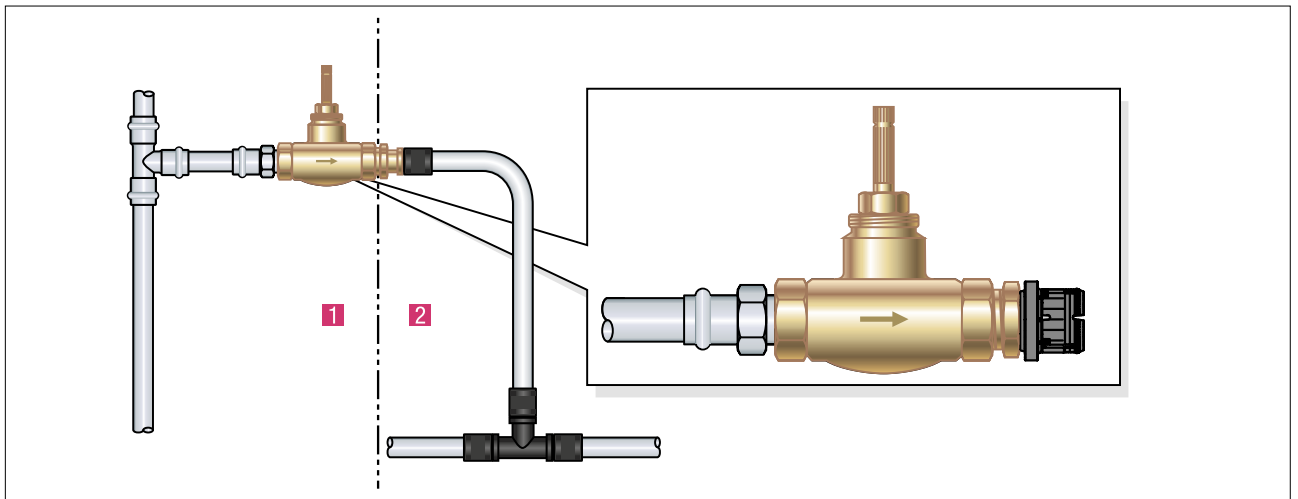

Fig. 6-5 Installation situation of a system adapter to a flush mounted valve (example)

- 1** Stainless steel system with flush-mounted valve **2** EDGE™ system with threaded EDGE adapters/fittings.

6.4 Pipe bending

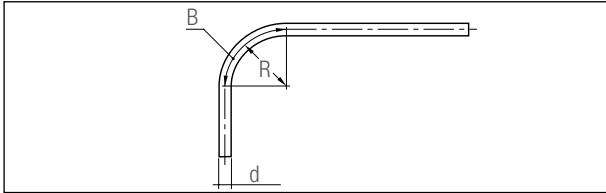

Fig. 6-6 Pipe bend

R Bending radius
B Arc
d Pipe diameter

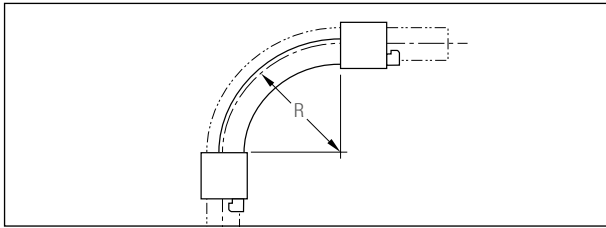

Fig. 6-7 Pipe bend bracket for plumbing 90 degrees, for size 16– 32 and pipe bend bracket for plumbing/heating 5 x d 90 degree for size 32

R Bending radius

EDGE™ pipes can be bent by hand and installed with or without a bend bracket depending on the desired radius as per table 6-1.

Minimum bending radius

- The minimum bending radius is five times the pipe diameter.
- When bending with a spiral spring, the minimum bending radius is three times the pipe diameter.
- The minimum bending radius is measured with respect to the centre of the pipe.
- After bending, ensure that there are no kinks, wrinkles or bulges. Replace the pipe if any of these kinds of damages are visible.

 Only cold bending of EDGE™ pipes is allowed.

Bending EDGE™ Pipes

	Using pipe bend brackets for plumbing/ heating (90°) 5 x d	Bent by hand (90°) 8 x d
Pipe sizes	Bending radius R [mm]	Bending radius R [mm]
EDGE Silver		
EDGE Red		
EDGE Green		
EDGE Lilac		
16	80	128
20	100	160
25	125	200
32	160	256

Tab. 6-1 Minimum bending radii of EDGE™ PE-Xa pipes

6.5 Pipe bends directly at a fitting

REHAU's recommended best practice is to install a joint such that the pipe entering the fitting is straight and not on a bend.

When installing a joint on a bent pipe:

- The distance measured perpendicularly from the bottom of the outer edge of the sleeve to the outer edge of the bent pipe must be at least 2.5 sleeve lengths (approx. 35mm for EDGE™ 16 / approx. 38mm for EDGE™ 20).
- As such, the maximum deflection of a branch pipe from the straight axis shall not exceed the following limits as shown in the images

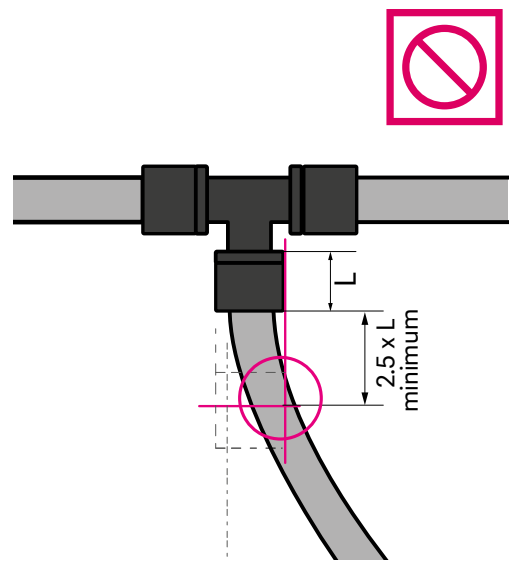
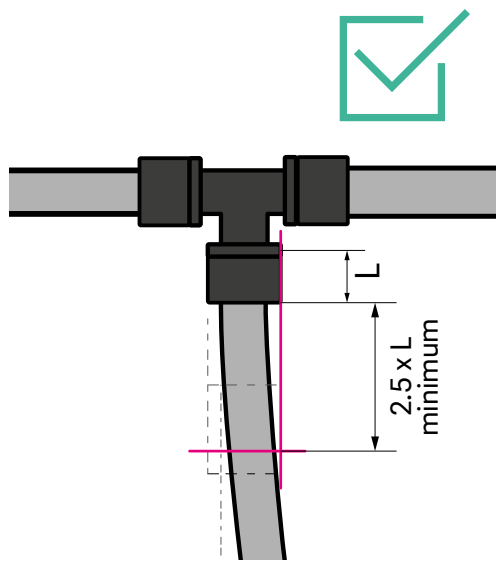

6.6 Pipe support and fixing

6.6.1 Pipe brackets and clips

Use only pipe brackets and clips with the following properties:

- Suitable for plastic pipes
- Improved acoustic properties through rubber lining
- Correct size (to allow easy gliding of pipe without pulling the rubber lining out)
- Free of burrs

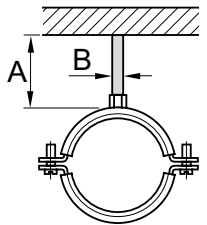
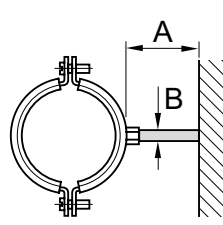
	B	A
Pipe size [mm]	Thread diameter or pipe nipple diameter	Maximum distance of wall/ceiling to the pipe clamp [mm]
		
16	M8	100
	M10	150
	M12	200
	M16	300
20	M10	100
	M12	150
	M16	250
25	M12	100
	M16	200
32	M16	100
	R ½	150

Tab. 6-2 Guideline values for fixing parameters of anchor points

6.6.2 Anchor points

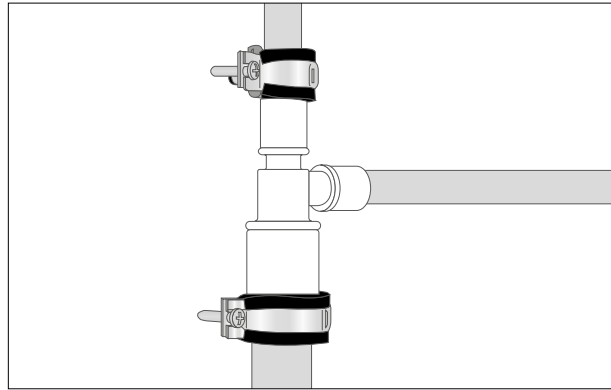

Fig. 6-8 Anchor point made by pipe clamps

- Anchor points can be used to restrict the thermal linear expansion into one direction.
- Long pipe runs can be divided into several sections by adding several anchor points.
- Anchor points can be fixed at tees, elbows or connectors. Anchor points can be fixed by installing a pipe bracket directly before each compression sleeve of the fitting.
- For installation without pipe support channel, install anchor points at 6 m intervals. Please refer to section 6-8 for more information on pipe support channels.



Pipe brackets shall not be installed on compression sleeves

6.6.3 Spacing between brackets and clips

Choose the correct pipe spacing intervals according to the guideline values (see Table 6-3) for installation with or without pipe support channels. AS NZS 3500 guidelines for bracket and clip spacing are also approved for EDGE™ pipes.

EDGE™ PE-Xa installation pipes	Size	Horizontal Installation			Vertical Installation		
		Concealed	Exposed	REHAU support channel	Concealed	Exposed	REHAU support channel
		Max. recommended spacing of brackets and clips (m)			Max. recommended spacing of brackets and clips (m)		
EDGE Silver							
EDGE Red							
EDGE Green	16	0.60	0.30	2.0	1.20	1.20	2.0
EDGE Lilac	20	0.70	0.40	2.0	1.40	1.40	2.0
	25	0.75	0.50	2.0	1.50	1.50	2.0
	32	0.85	0.70	2.0	1.70	1.50	2.0

Tab. 6-3 Recommended spacings of pipe bracket/clip for EDGE™ PE-Xa pipes

6.7 Installation in wooden joists or steel frames

Avoid holes and notches in wooden joists wherever possible. If crossing wooden joists or steel frames:

- Adequately size pipe penetrations in wooden joists or steel frames.
- Use pipe grommets or similar to protect the pipe from damage.
- For specific information on hole size and spacing for wooden joists and steel frames, refer to AS/NZS 3500.

6.8 Pipe support channel

When installing pipes in exposed areas or installing long piping without change in direction, we recommend using pipe support channel for EDGE™ PE-Xa pipes.

REHAU pipe support channel is clipped onto and firmly holds on the pipe. It stabilizes the pipe against sagging and improves the visual appeal in exposed areas. When using pipe support channel, bracket spacing can be increased to 2m regardless of the pipe size.

Due to its axial clamping forces, pipe support channel also reduces thermal expansion, therefore reduces the number of deflection legs required.

 For installation of EDGE™ PE-Xa pipes without pipe support channel, pipe sagging is to be anticipated.

6.8.1 Functionality

The pipe support channel covers the pipe by about 60 % and is shaped to closely encase the pipe without additional fastenings. This strong clamping effect prevents the pipe from bending and reduces thermal expansion in length.

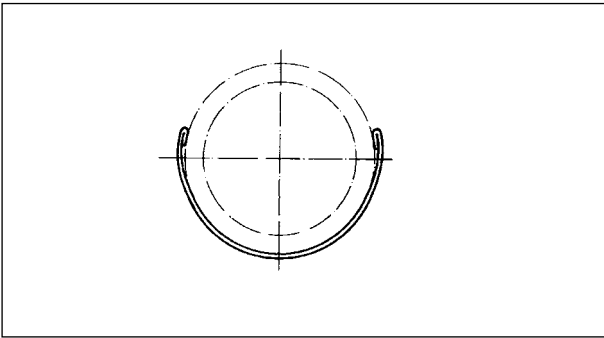

Fig. 6-9 Cross-section of pipe support channel

6.8.2 Assembly of the pipe support channel

Do not fit pipe support channel or pipe fasteners close to the deflection legs so the pipe can still bend.
Pipe cover

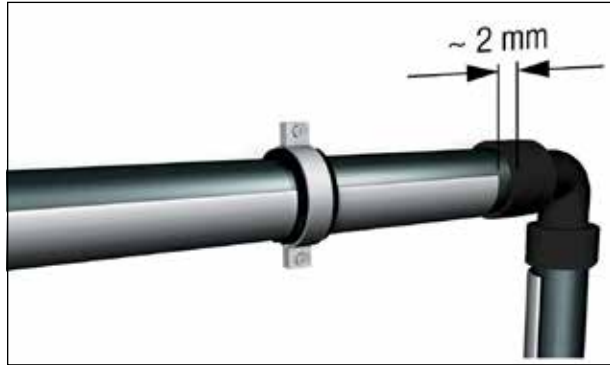

Fig. 6-10 Let the pipe support channel end approx. 2 mm before compression sleeve

The pipe support channel must be fitted over the entire length of the piping up to 2 mm before the compression sleeve, as only this ensures reduction of the thermal expansion length.

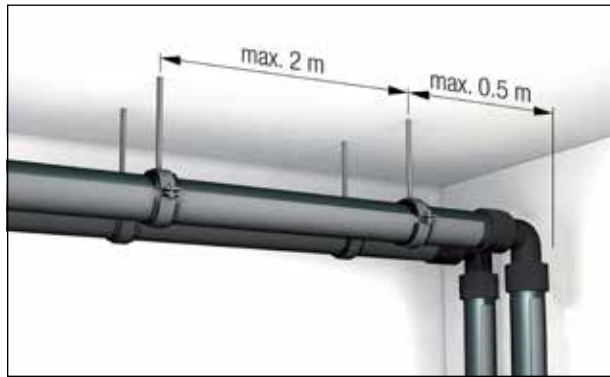

Fig. 6-11 Maximum pipe clamp intervals

The maximum pipe clamp interval when using the pipe support channel is 2m for all sizes. The distance from the pipe end, or when changing direction, to the first pipe fastener may not exceed 0.5 m. This way, pipe brackets for pipe routing or in cellars can be attached in a uniform and effective manner.

6.8.3 Fitting cover

Clipping over the fitting is not possible with EDGE Fittings.

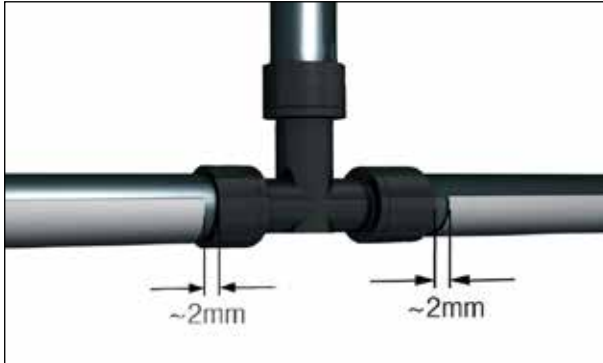

Fig. 6-12 Do not clip over EDGE™ Fittings

6.8.4 Assembly of the pipe support channels

Reduced retaining force of the pipe support channel can cause greater thermal expansion of the pipe.

Do not lessen the retaining force of the pipe support channels by storing or assembling them improperly.

1. Cut off the pipe support channel with a metal saw. Maintain a safe distance between your holding hand and the cutting tool. Saw pipe support channels from the rounded rear side, not the open side so that they are not bent open at their bordered ends.

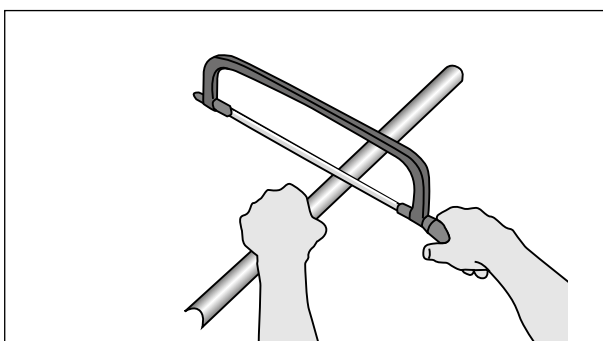

Fig. 6-13 Cutting off pipe support channel

2. If the pipe support channel has been bent inwards or outwards when it was cut to length, bend the pipe support channel back to its original shape.

3. Deburr the ends of the pipe support channel.

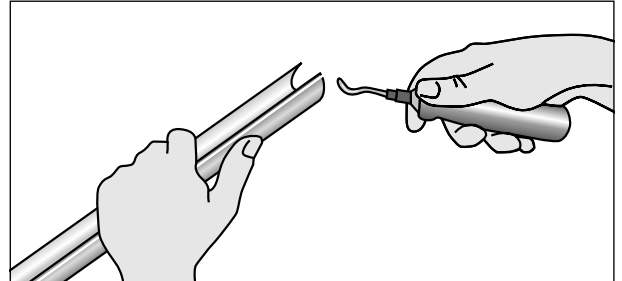

Fig. 6-14 Deburring of pipe support channel

4. Clip the pipe support channel onto the pipe (by hand or using a pliers or pipe wrench with plastic jaws). Do not overlap the ends of pipe support channels.

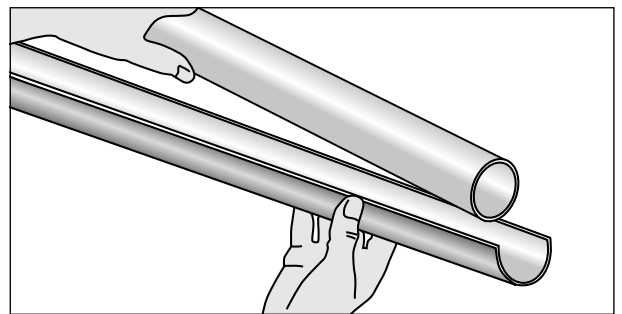

Fig. 6-15 Clipping in pipe support channel

5. To join support channels together, use cut-offs clipped over both ends.

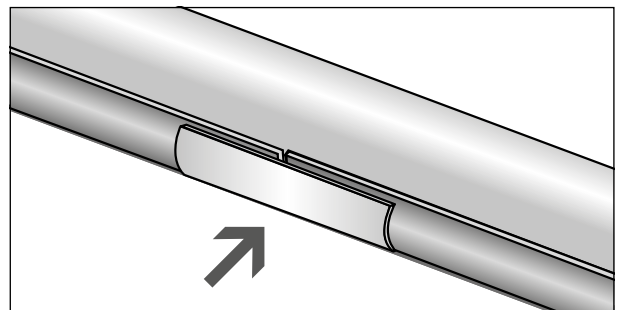

Fig.6-16 Joining two pipe support channels

Even short cut-offs of the pipe support channel can be used for clipping over joints, ensuring an almost waste-free installation.

6.9 Provision for thermal expansion

6.9.1 Calculating thermal length changes

Due to the changing operational temperatures, especially in hot water pipes, any pipe material will undergo thermal expansion. This thermal expansion needs to be managed in a safe way to avoid tension in unwanted locations along the pipe length.

Any fixed points that restrict the free expansion and contraction of the pipe must be avoided. Such fixed points may inadvertently be created when fittings are installed close to penetrations in walls, floors, joists or other fixed building elements.

Make sure that the piping has sufficient scope for movement (e.g. from deflection legs).

The thermal change in pipe length is calculated with the following equation:

$$\Delta L = \alpha \cdot L \cdot \Delta T$$

- ΔL = Length change in mm
- α = Coefficient of linear thermal expansion in $\frac{mm}{m \cdot ^\circ C}$
- L = Length of piping in m
- ΔT = Temperature difference in $^\circ C$

The ΔL value resulting from this equation is the change in length of a pipe due to thermal expansion. Excessive length changes may cause potential stress on joints in the system. The effects of this stress can be mitigated by using deflection legs. EDGE™ PE-Xa pipes are particularly suitable for this due to their flexibility.

The coefficient of linear thermal expansion must be selected according to the installed pipe type and if pipe support channel is installed.

Determining the pipe length

The pipe length L is the actual installed pipe length on site between anchor points, expansion bends or loops. Sometimes it may be necessary to divide the pipe run into several sections by adding anchor points or expansion bends and loops to limit the change in length per section.

Determining the temperature ΔT

To determine the temperature difference ΔT , the following shall be taken into consideration:

- Installation temperature or minimum operating temperature (e.g. when the system is out of service)
- Maximum operating temperature (e.g. thermal disinfection)

Pipe type	Pipe size	Coefficient of linear thermal expansion α [$\frac{mm}{m \cdot ^\circ C}$]	Material constant C
		$\Delta L = \alpha \cdot L \cdot \Delta T$	$L_{DL} = C \cdot \sqrt{d_o \cdot \Delta L}$
EDGE Silver	16-32 without REHAU support channel	0.15	12
EDGE Red			
EDGE Green	16-32 with REHAU support channel	0.04	12
EDGE Lilac			

Tab.6-4 Coefficient of linear thermal expansion (approximate values) and material constants for deflection leg calculation (approximate values)

6.9.2 Deflection legs

A deflection leg is the freely moveable pipe length, which can take up the required thermal length changes. The length of the deflection leg is influenced mainly by the material (material constant C).

Deflection legs result mostly from changes in direction of the piping. For long piping lengths, additional deflection legs must be installed in the piping to compensate the thermal length changes.



Do not fit pipe support channels or pipe brackets on deflection legs as this would restrict their flexibility.

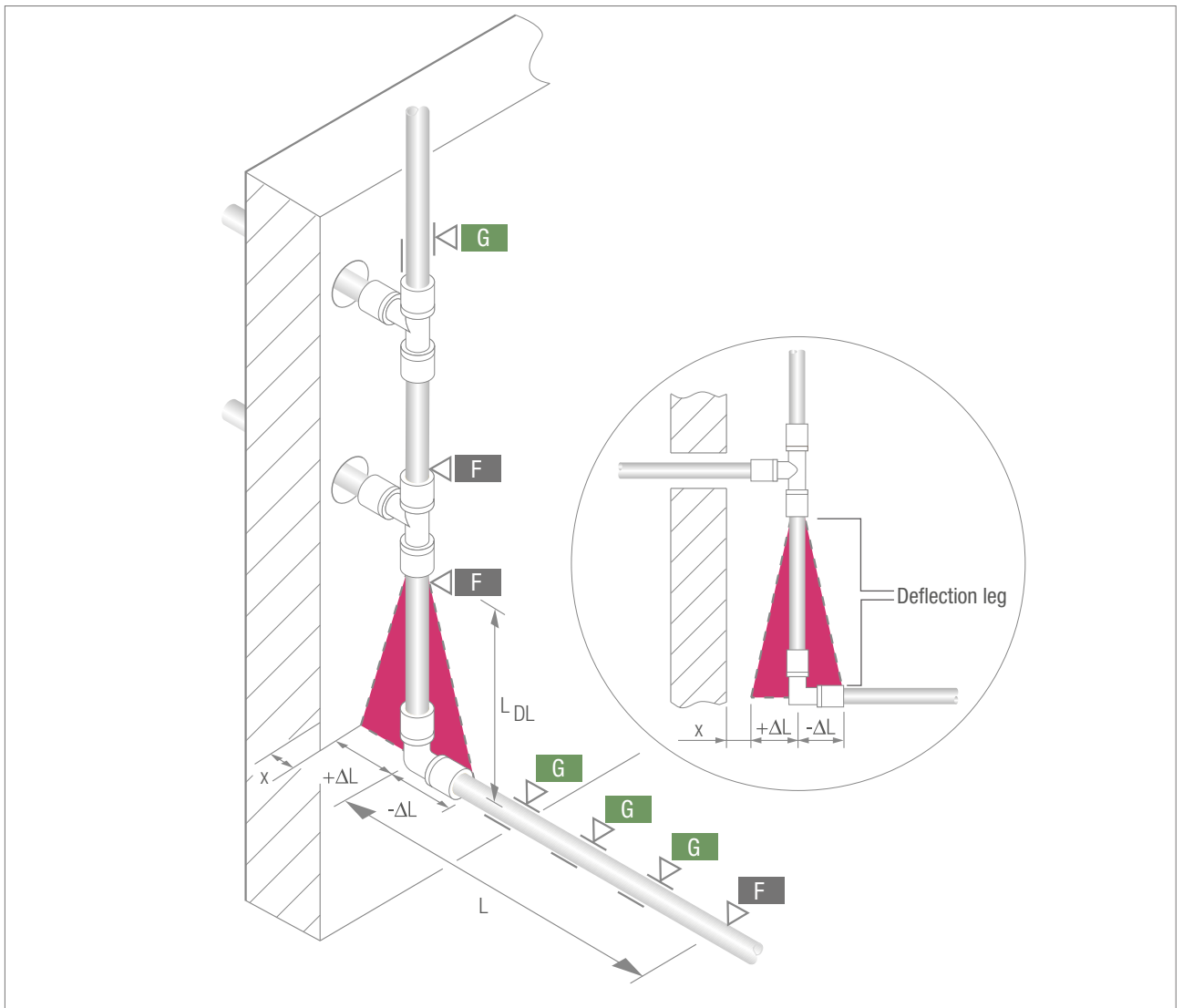

Fig. 6-17 Deflection legs

- L_{DL} Length of deflection leg
- ΔL Thermal length change
- L Pipe length
- x Minimum distance of the pipe from the wall
- F** Fixed/anchor point (tight)
- G** Gliding point (loose)

6.9.3 Calculation of deflection leg length

The minimum length of deflection length (DL) is calculated by the following formula:

$$L_{DL} = C \cdot \sqrt{d_o \cdot \Delta L}$$

- L_{DL} = Length of deflection leg
- d_o = Outer pipe diameter in mm
- ΔL = Length change in mm
- C = Material constant of piping material

i For approximate values for material constant C, see Table 6-4.

Do not fit pipe support channels or pipe brackets close to the deflection legs so it will not be prevented from bending.

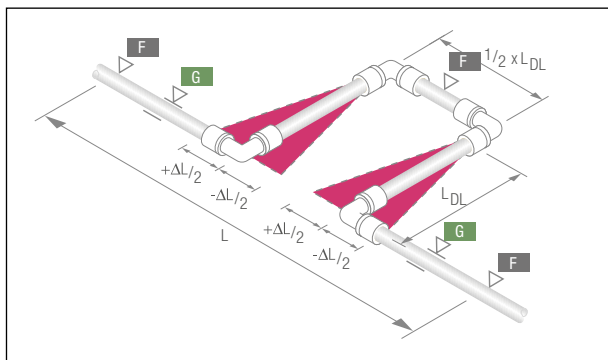

Fig. 6-18 U expansion bends
 L_{DL} Length of deflection leg
 ΔL Thermal length change
 L Pipe length

6.9.4 Calculation examples

The pipe length L, for which the thermal length changes is to be accommodated at a deflection length, is 7m.

The temperature difference between the minimum and maximum values (installation temperature and subsequent operating temperature) is 50 °C. The installed pipe outer diameter is 25mm.

What length of deflection leg is required according to the installed pipe type?

Calculation of deflection leg length with EDGE™ pipe

$$\Delta L = \alpha \cdot L \cdot \Delta T$$

$$\Delta L = 0.04 \frac{mm}{m \cdot ^\circ C} \cdot 7m \cdot 50^\circ C$$

$$\Delta L = 14 mm$$

$$L_{DL} = C \cdot \sqrt{d_o \cdot \Delta L}$$

$$L_{DL} = 12 \cdot \sqrt{25mm \cdot 14 mm}$$

$$L_{DL} = 224 mm$$

For metallic pipe materials, a substantially larger deflection leg is required for the same operating parameters during installation, due to the significantly higher material constant (C), than for EDGE™ pipes system.

6.10 Thermal insulation

Thermal insulation requirements for hot and cold water services are specified in the National Construction Code NCC and in AS/ NZS 3500.

In cold water applications, the likelihood of pipe damage due to freezing can be reduced. It is, however, not possible to prevent static water from freezing completely. For longer periods during which freezing is likely to occur, pump warm water periodically through the pipe system. Alternatively, the complete system should be drained.

6.11 Noise reduction

Effects of water hammer:

The low elastic modulus of PE-Xa pipes and their ability to expand quickly and contract slowly enables the pipes to absorb water hammer effectively.

In cold water service installations, the water hammer effect can be reduced by up to 75% compared to metal pipe installations.

6.12 Water heater connection

EDGE™ silver and EDGE™ red system can be used for recirculating hot water systems provided the operating temperature, pressure and level of disinfectants does not exceed the capabilities of the piping system. Refer to Chapter 8.

REHAU recommends the installation of both isolation valve and non-return valve connected directly to the inlet of every water heater or with metallic piping between the valves and the water heater. REHAU recommends that the non-return valve be connected closest to the water heater and with the isolation valve at the up-stream of the non-return valve.

6.12.1 Storage water heaters

All storage water heaters should be fitted with operational temperature and pressure relief valves for safety in the event of malfunction of the heater's operation. The rating of the temperature and pressure relief valve must be determined by the storage water heater manufacturer in terms of maximum temperature and pressure as required for the design and operational requirements of the water heater.

If the storage water heater does not have provision on the heater for fitting such a valve, REHAU recommends the installation of a temperature and pressure relief valve on the tee-connection of the heater's hot water outlet and its outlet piped to a drain location. This will allow the release of hot water during the heater's normal operation and in the event of safety operation of the valve. REHAU also recommends that the valve be operated manually every six months.



Outlets of storage water heaters must be fitted with a minimum of 1 meter of metallic piping prior to the installation of EDGE™ silver or EDGE™ red system.

6.12.2 Instantaneous water heater

Before connecting EDGE™ piping system to either electric or gas-fueled instantaneous water heaters, the installer must check the appliance manufacturer's instructions regarding the connection of polymer pipes. The appliance operational temperature and pressure may exceed the capabilities of EDGE™ piping and might cause failure of the piping system. Some manufacturers of instantaneous water heaters state that connection of their appliances to polymer piping systems is not suitable or subject to restrictions.

The installer must confirm with the appliance manufacturer that the maximum operational limits of the appliance will not exceed those of the piping system. REHAU recommends that only appliances with temperature control devices which can, at all times, restrict the outlet water temperature to within EDGE™ piping system's capabilities, be installed in conjunction with EDGE™ piping system.

6.12.3 Water heaters with uncontrolled energy sources

EDGE™ silver and EDGE™ red pipes should not be used with uncontrolled energy sources and installation of a tempering valve is required.

6.12.4 Solar water heaters

As per AS/NZS 3500 requirement, polymer pipe systems must never be used on the flow and return piping to any solar panel.



Solar collectors and other uncontrolled heat sources generally have operating conditions which exceed those of EDGE™ pipe system.

- Never use EDGE™ pipes in the flow and return piping to any solar collectors/panels.
- Do not install EDGE™ pipes in the flow and return of any uncontrolled heat source (e.g. wood fire heaters, etc.).
- If a heat storage tank is used, EDGE™ pipes can be used after the tempering valve. Potential back siphoning of super heated water through the cold port of the tempering valve from cold feed to the uncontrolled heat source (including solar panels) must be prevented through adequate measures, e.g. fitting a suitable high temperature rated non-return valve between the cold feed to the solar panels and the tempering valve.

07 System protection

7.1 General

- Prior to any installation, ensure all components being used are REHAU EDGE™ components only
- Do not use dirty or damaged system components, pipes, fittings, compression sleeves or seals.
- Make sure that the connection components are free of inadmissible stress during assembly and when in operation. Make sure that the piping has sufficient scope of movement (e.g. from deflection legs).
- Protect the system against damage (e.g. during the construction phase and when installed in areas with vehicles and machines)

Installation temperature

- Minimum installation temperature is -5°C
- Maximum installation temperature is +50°C

For maximum operation temperature refer to Chapter 8.

7.2 Protection against corrosion and damage

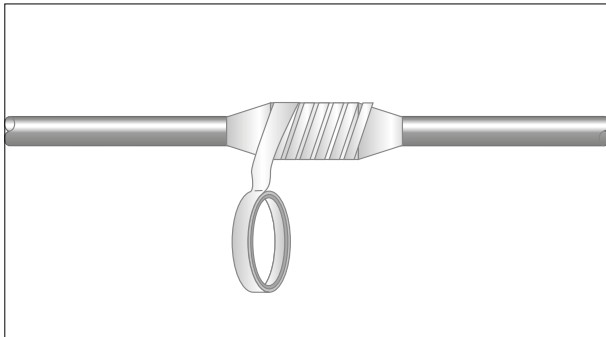
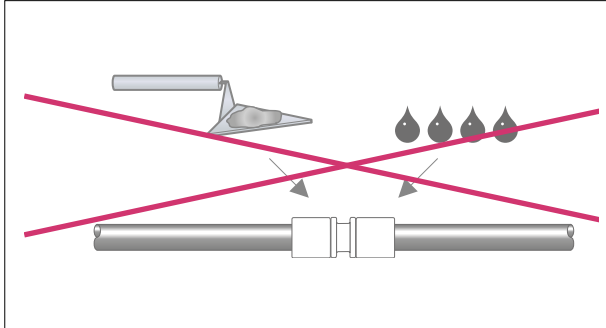

Fig. 7-1 Protect connection components against corrosion and damage



- Screed, cement, mortar, plaster, bonding agents and other materials and substances may cause corrosion. Where a contact with such substances is foreseeable, protect fittings and compression sleeves from contact, e.g. by wrapping with RAUTITAN protective tape, silicone tape or another suitable tape. Petrolatum tapes, or tapes containing solvents are NOT suitable.
- Do not install pipes and fittings, pipes and compression sleeves in wet areas (e.g. green houses, indoor pools, or conditions where water or condensation on the surfaces must be expected on a regular basis)

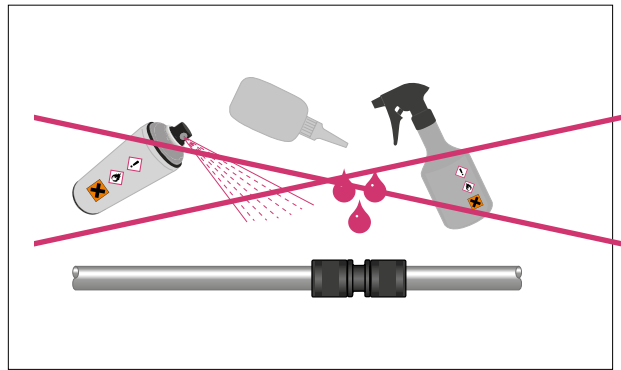

Fig. 7-2 Avoid contact with solvents and oils including paints, lacquer, liquid thread sealant and tapping oil.

EDGE™ polymer fittings

- EDGE™ polymer fittings are solvent resistant and have excellent resistance against most aliphatic and aromatic hydrocarbons and Chlorine. Solvent resistant means that EDGE™ polymer fittings are not susceptible to environmental stress cracking when in contact with solvents found in glues, primers and thread sealants commonly used on building sites. Only use leak detection agents (e.g. foaming agents), sealants, thread sealants, cleaning agents, building foams, insulation, protective tape, adhesive tape and flux, which were approved by the respective manufacturer for PVDF.
- When using the connection components, check the compatibility of materials for the corresponding area of application.
- Contact with basic environments with $\text{pH} \geq 12$ is not permitted.

Protect EDGE™ pipe and fittings from contact with:

Substance*	Examples*
Alcohol	Isopropanol, Ethanol, Methylated Spirits
Acetic Acid	Dyes, Ink, Paints
Glues/adhesives	Liquid thread sealant, PVC glue, insulation glue, some gypsum board glues, some adhesive tape, other glues or tapes which are not specifically approved for polymer materials
Grease and Oil	Most cutting oils and other oils, greases, Petrolatum
Paint and Lacquer	Most paints and lacquers, including water based
Primers	PVC primer, paint primers, other primers
Solvents	Cleaning agents, acetone, ketone, ether, MEK, some marker pens, some PUR building foams, other substances containing aromatic or oxygenated solvents
Other	Avoid contact with any substance that cause stress cracking or corrosion, i.e. Plasticizers, ammonia, halogenated hydrocarbons or chloride ions that can leach.

* The substances mentioned above reflect our current knowledge of substances that may be part of chemicals used on construction sites which can cause stress cracking or corrosion to fittings or pipes; any new substance that may be forthcoming in the future may not be compatible will be excluded from our warranty upon notification.

If incidental contact occurs, confirm compatibility with EDGE™ pipes and fittings.

When installing EDGE™ components and in aggressive environments (e.g. exposed to cleaning agents, aggressive gases, chloride mediums), protect pipes and fittings against corrosion adequately and in such a way that they are sealed against vapours.

7.3 Transport and storage

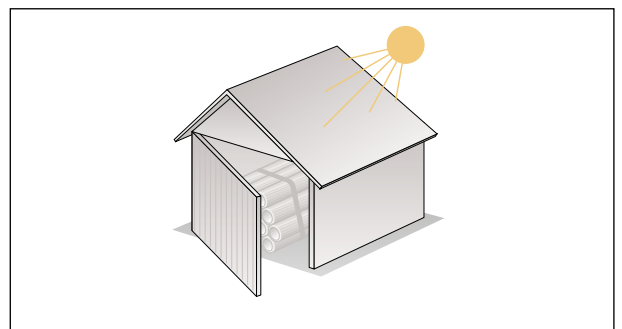

Fig. 7-3 Protect pipes against sunlight

Protect pipes and fittings against UV radiation during storage and transportation. When installing in areas where UV-radiation (e.g. sunlight, neon light) can occur, cover the piping fully with UV-proof material.

Avoid damaging the pipes and system components:

- Load and unload with due care.
- Only transport in a fashion suitable for the material.
- Do not drag over floors or concrete surfaces.
- Store on a flat surface with no sharp edges.
- Protect against mechanical damage.
- Protect against dirt, drilling dust, mortar, grease, oil, paint, solvents, chemicals, humidity, etc.
- Protect against sunlight, e.g. with an opaque film or similar material.
- Protect against long sunlight exposure during the construction phase.
- Only unpack shortly before installing.
- For hygiene reasons, cap or seal open pipe ends and protect pipes and fittings from contact with harmful substances.

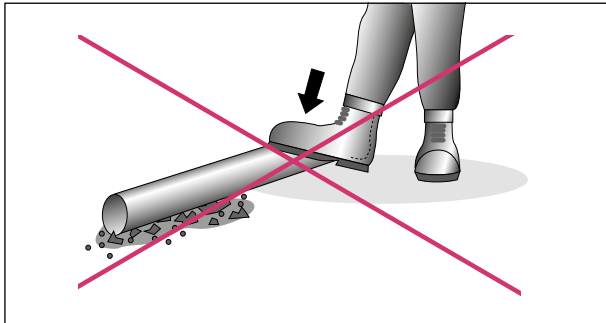

Fig. 7-4 Do not store pipes on sharp-edged surface

7.4 Installation within concrete/screed floors and walls

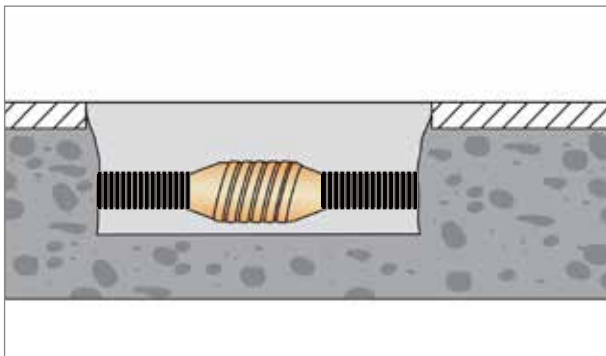

Fig. 7-5 Installation of EDGE™ system within concrete/screed floor with corrosion protection system

Installation of EDGE™ systems within concrete/screed floors and walls are allowed, provided specific requirements from local installation standards are fulfilled and adequate protection from mechanical damage and chemical damage are provided. Fittings shall be wrapped with suitable tape to avoid direct contact with concrete. Pipe must be laid in conduit.

7.5 Installation beneath a concrete slab

Water service pipes located beneath concrete slabs on ground shall conform to the following:

- There shall be a minimum distance of 75mm between the top of the pipe and the underside of the slab or slab-stiffening beam. In addition, hot water pipes shall be insulated in accordance with Clause 7.2 of 3500.4
- The ends shall be capped off prior to pouring of the concrete. The exposed pipe shall be protected from damage.
- Any pipework that penetrates the slab shall be at right angles to the surface of the slab and lagged for the full depth of the slab penetration with:

- An impermeable flexible material of not less than 6mm thickness, or
- Impermeable plastics sleeve or conduit providing equivalent protection

NOTE: where termite protection is required, the integrity of the chosen termite protection method should not be compromised.

- The number of joints shall be kept to a minimum

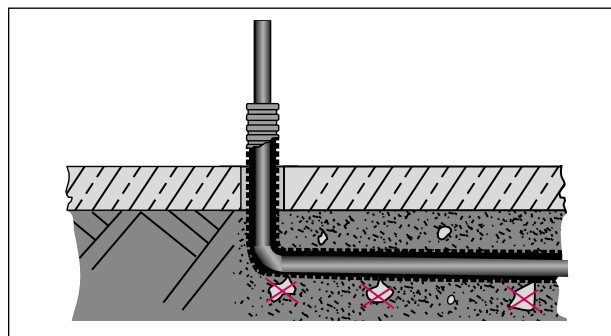

Fig. 7-6 Installation of EDGE™ system beneath concrete/screed floor with corrosion protection system

7.6 External installation above ground

All external installations shall follow the applicable water installation standards.

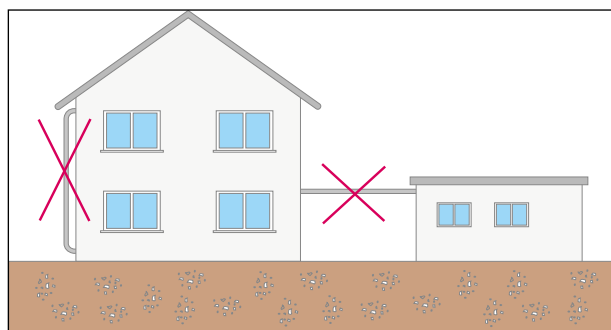

Fig. 7-7 External installation prohibited

REHAU EDGE™ system components shall in general not be installed above ground, except for the following:

- Short pipe length after connection to water meter before going in ground
- Connection to an externally located water heater

For the above exceptions, the following must be ensured:

- The length of pipe installed above ground shall be kept to an absolute minimum not exceeding 2 metres. Below ground installation should always be preferred.
- All pipe and connections must be adequately protected from corrosion, frost and excessive temperature.
- The system components must be protected from any mechanical and physical damages. Consideration shall be given to the type and level of damage that is likely to occur during the long term operation of the system, e.g. UV-radiation, lawn mower, etc.

7.7 Installation below ground



All below ground installations shall follow the applicable water installation standards

General

REHAU EDGE™ system components can be installed in the ground if they are adequately protected against mechanical and chemical damage and contamination.

Installation of EDGE™ pipes in contaminated soil (ie. petrol, benzene, paint, solvent etc.) is not permitted.



If chemical damage is likely to occur, e.g. from termite treatments, EDGE™ pipes and fittings shall be adequately protected using a suitable conduit, e.g. PVC pipes or equivalent.

Bedding and backfill

The quality of bedding and backfill material must be in accordance with valid national water installation standards.

Corrosion protection

All joints in ground must be protected against corrosion using a recognized corrosion protection system, such as the Denso DEKOTEC N15/PE5 system or equivalent. Do not use protective tapes containing Petrolatum, solvents or other harmful substances.

The corrosion protection system shall cover a minimum of 150 mm of the pipe on each side of the joint. Ensure mechanical protection is provided to avoid any damage to the corrosion protection tape e.g. by backfill material.



Inadequate corrosion protection of joints may cause corrosion of EDGE™ brass fittings and lead to leakage

EDGE™ polymer fittings and compression sleeves when installed with EDGE™ PE-Xa pipes must be mechanically protected, i.e. by laying in a sand bed or by sliding a piece of pipe with larger diameter over the joint.

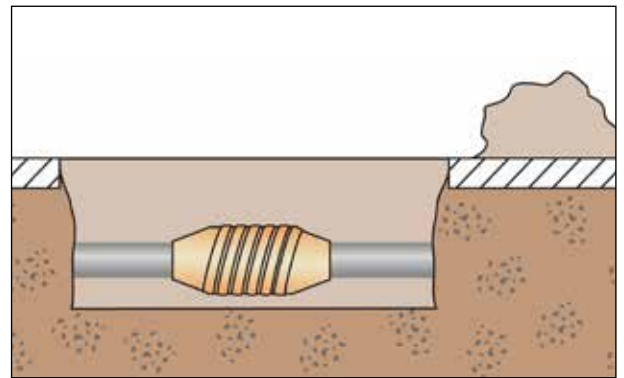

Fig.7-8 Installation of EDGE™ system below ground with fittings wrapped with corrosion protection system

7.8 Installation in areas exposed to UV radiation and light

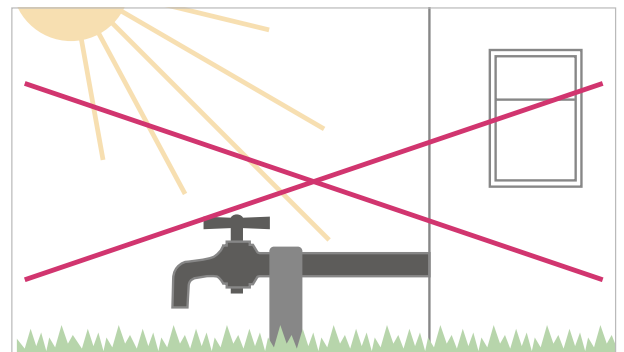

Fig. 8-9 Unprotected installation in areas exposed to UV radiation is not permitted
Example: Outdoors

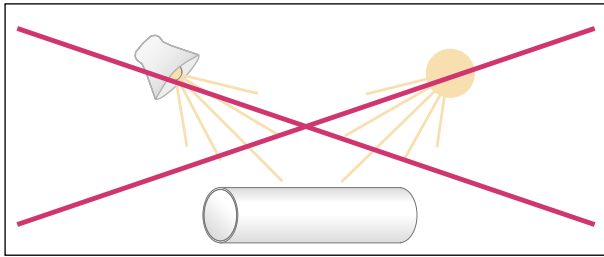

Fig. 7-10 Unprotected installation in areas exposed to UV radiation or light is not permitted. E.g. indoors



- Pipes and fittings must be protected against UV radiation during storage and transportation
- Protect piping from UV rays in areas where UV radiation can occur (e.g. sunlight, neon light) i.e by installing in black conduit.
- EDGE PE-Xa pipes shall be installed in dark areas or protected in conduit to avoid biofilm growth.

7.9 Exposure to excessive heat

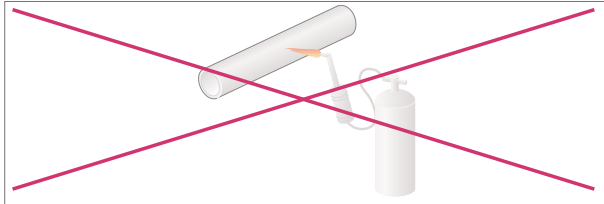

Fig. 7-11 Protect piping against exposure to excessive heat

During construction, maintenance or repair work in close proximity to heat, care must be taken not to expose EDGE™ system components to a naked flame (soldering), flood lights or other localised heat sources. This can result in permanent damage or a significant reduction in performance life.

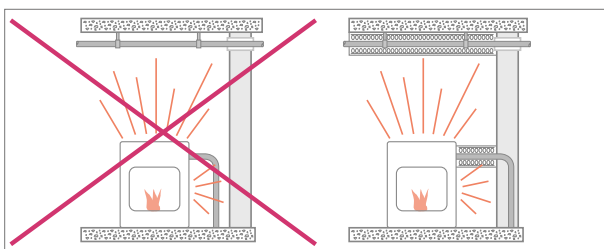

Fig. 7-12 Protection against temperature-induced stress

7.10 Heat trace

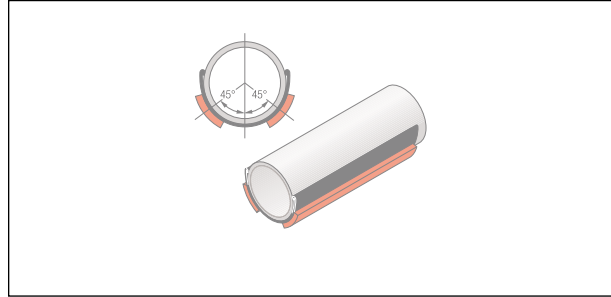

Fig. 7-13 Example of trace heating fitted to EDGE™ pipe with support channel

The use of heat trace on EDGE™ pipes is permissible provided the heat trace temperature is limited to 60°C at any point.

In pipes installed with pipe support channel, the heat trace must be attached to the outside of the pipe support channel.

Observe the installation manual of the auxiliary heating manufacturer and ensure that any tape used to fix the heat trace to the pipe is suitable for contact with EDGE™ components.

7.11 Potential equalisation

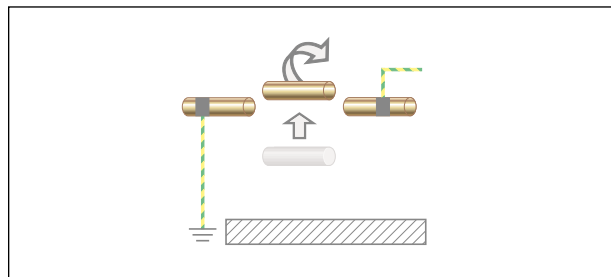

Fig. 7-14 Potential equalisation while replacing pipes



EDGE™ piping shall not be used as an earthing conductor.

After replacement of existing metal pipe installations with the EDGE™ system, the function of potential equalization and the effectiveness of the electrical safety devices must be verified by an electrician.

08 Design and operating guidelines

8.1 Standards and guidelines

§ EDGE™ system for water services must be planned, calculated, installed and operated according to AS/NZS 3500 and other relevant standards.

8.2 Operating parameters

The following operating parameters must not be exceeded.

Application:

Hot water supply : 60°C / 1 MPa (10 bar)
or 70°C / 800 kPa (8 bar)
(Application class 1-2 acc. ISO 10508)

The above operating parameters are based on a life span of 50 years and allow for short periods of higher temperatures as listed in the following table:

Design Temperature T_D / Time T_D	70°C / 49 years
Short-term maximum temperature T_{max} / Time T_{max}	+ 80°C / 1 year
Short-term malfunction temperature T_{mal} / Time T_{mal}	+ 95°C / 100 h
Total	= 50 years

Tab. 8-1 Operating parameters according to DIN EN 806-2, DIN 1988-200 and ISO 10508 (Application classes 1 and 2)

8.3 Hot water ring mains

EDGE™ pipes and fittings are suitable for installation in hot water circulatory flow and return line (ring main) applications, with or without copper pipes installed in the same line, provided the temperature does not exceed 60°C and the operating pressure is limited to 6 bar (600kPa). The maximum permissible water velocity under those conditions is 3.0 m/s. Note - AS/NZS 3500.4 limits the maximum permissible velocity to 2.0 m/s.

Refer to Chapter 8.6 for maximum allowable levels of disinfectants.

These operating conditions are limited to ring main applications only, and do not apply to general hot water applications, including branch lines from a ring main. Refer to section 8.2 for operating parameters for normal hot water applications.

In a scenario where a non-REHAU system is used as the main circulation line in a ring main application and EDGE™ is used as a branch line, ensure that there is a distance of at least 200 mm between ring main line and the EDGE™ system.

8.4 Drinking water requirements

The drinking water must comply with the currently valid limits of the following standards:

- Australian Drinking Water Guidelines

Nonetheless, no material exists that can be used for every application.

In some specific cases, even drinking water qualities within the permitted range of the drinking water guideline and standards have properties that may negatively affect DZR brass fittings and lead to corrosion.

The maximum disinfection agent concentration mentioned in above guidelines shall only be applied during temporary disinfection and not continuously. Refer to table 8.2.

In locations with highly corrosive water composition, e.g. in volcanic areas, installations using bore/well water etc., the suitability of EDGE™ pipe system must be checked with REHAU. In some cases, the available water quality may void the REHAU warranty unless appropriate water treatment is provided.

8.5 Water chemistry limitations

High levels of chloride content combined with low levels of hydrogen carbonate content may negatively influence the corrosiveness of the drinking water and lead to dezincification of DZR brass materials.

To avoid corrosion of EDGE™ MX Brass fittings in drinking water application, the following limits shall not be exceeded:

- Chloride contents (Cl-) ≤ 200 mg/l
- Sulphate content (SO₄²⁻) ≤ 240 mg/l
- Calculated calcite solubility capacity (achieved as soon as pH value ≥ 7.7) ≤ 5 mg/l



Treated drinking water (e.g. softened water) may be corrosive to EDGE™ components.

- Verify supplied water from the treatment plant suits to all materials used in EDGE™ water installation system.
- REHAU explicitly recommends to consult an expert or the system manufacturer for an assessment of the individual situation and to ensure correct design, installation and operation of water treatment plants. It is the responsibility of the system designer to ensure that the above-mentioned factors and parameters are taken into account to prevent corrosion and scaling. If the drinking water quality is outside the limits of the drinking water guidelines or above limits, or if previous experience indicates corrosive tendencies of the supplied water, consult REHAU before using EDGE™ system.

8.6 Disinfection of water services

EDGE™ pipes intended for drinking water together with the EDGE™ jointing technique without an O-ring help to keep the hygiene level of drinking water installation. They correspond to the requirements of AS/NZS 4020. Thus, they are suitable for contact with drinking water. It has been proven by KIWA that PEX pipes for water services and heating installation do not cause any multiplication of micro-organisms and thus do not support microbial contamination or legionella growth.

8.6.1 Thermal disinfection in case of contamination

For drinking water installations in compliance with the latest technical standards (no stubs, etc.), removal of dirt can be done by thorough water rinsing as long as the dirt is water-soluble or remains soluble in water.

If contamination is suspected, an additional thermal disinfection as per DVGW worksheet W 551 is possible as a sensible and urgent measure. According to the latest technological standards, for water with temperature of at least 70°C, it is very likely that germs and bacteria, including legionella which is found freely in water will be killed off. It is important that the appropriate measures have to be taken to avoid scalding to people.

All EDGE™ piping system for water services and heating installation are suitable for multiple thermal disinfections according to DVGW worksheet W 551 at 70°C. It must be ensured that the allowable operating pressure is not exceeded during thermal disinfection.

8.6.2 Chemical disinfection in the case of contamination

Alongside with thermal disinfection, chemical disinfection is being used more and more. Chemical and thermal disinfection measures always strain the materials used in water services installation. According to today's level of awareness, some disinfection measures are not suitable for standard materials in installation technology. This also applies to materials, for which it was previously assumed that they were sufficiently corrosion-resistant, e.g. stainless steel, copper and some synthetic materials.

Before introducing these types of process measures, it needs to be ensured that all parts of the installation system are thermally and chemically suited for the corresponding measure. This is regulated by DVGW worksheet 551. If necessary, please have the suitability of the disinfectant approved by the disinfectant's manufacturer for all system parts of the installation.

8.6.3 Chemical "Postrinse disinfection"

For short-term chemical disinfection (postrinse disinfections), only special active ingredients may be used which are specified in corresponding rules and standards.

Carrying out the disinfection measures according to the specifications of DVGW worksheet W 291 can be done without impairing the functionality of REHAU drinking water installation if the active ingredients, concentrations, application duration and maximum temperatures are observed (as listed in Table 8-2)

It should be noted that combining thermal-chemical disinfection at temperatures of higher than 25°C, as well as permanent or regular disinfection cycles (e.g. monthly), are not permitted.

In relation to the lifespan of the piping, the total number of disinfection cycles is limited to five "postrinse disinfections". Otherwise, it cannot be guaranteed that the specified lifespan will be reached.

The person carrying this out must guarantee that the water is not used for human consumption (e.g. as drinking water) at any time during the disinfection phase, including the subsequent rinsing phase.

Description	Commercial size and packing	Storage	Safety advice ¹⁾	Max application concentration ²⁾
				Application duration and temperature in the piping
Hydrogen peroxide H₂O₂	Hydrous solution with maximum 150g/l chlorine	Light-protected, cool, avoid contamination at all costs	With >5% solutions, protective equipment necessary	150 mg/l H ₂ O ₂ Max. 24h Tmax ≤ 25°C
Sodium hypochlorite NaOCl	Hydrous solution with maximum 150g/l chlorine	Light-protected, cool, sealed and in a collecting reservoir	Alkaline, corrosive, toxic, protective equipment necessary	50 mg/l chlorine Max. 12h Tmax ≤ 25°C
Chlorine dioxide ClO₂	Two components (Sodium chloride, sodium peroxide sulphate)	Light-protected, cool and sealed	Oxidizing effect, do not inhale chlorine dioxide, protective equipment necessary	6 mg/l ClO ₂ Max. 12h Tmax ≤ 25°C

Tab. 8-2 Chemical postrinse disinfections, active ingredients and concentrations according to DVGW W 291

¹⁾ The corresponding notes in the safety data sheets of the manufacturer must be adhered to.

²⁾ REHAU approval: this value may not be exceeded at any stage of the entire application duration of the installation.

8.6.4 Continuous chemical disinfection

To ensure the life span of EDGE™ pipes is not reduced by inappropriate use of disinfectants, ensure the maximum concentration and application duration of chemical disinfection consisting of either free Chlorine or Chlorine Dioxide, as shown in Tab. 8-3 are not exceeded at any time. The maximum application duration refers to the maximum accumulated duration during the entire lifespan of the system.

- 1) The corresponding notes in the safety data sheets of the manufacturer must be adhered to.
- 2) REHAU approval: this value may not be exceeded at any stage of the entire application duration of the installation.
- 3) Maximum lifespan application duration is an accumulation of the entire system lifespan.

Operating pressure 600 kPa assumed for all conditions.

In hot water applications above 50°C, the maximum permissible concentration of free Chlorine depends on the operating conditions (temperature, usage pattern) and water quality (pH value, ORP). Consult REHAU for advice.

Contact your local REHAU office for advice on operating conditions other than outlined above.

We generally exclude other non-listed disinfectants from being used, especially strong oxidants (e.g ozone), Chloramine etc.

Description ¹⁾	Application temperature in the piping	Max. application concentration ²⁾	Max. application duration in the piping ³⁾
Chlorine	Max. 50°C	Max. 5 mg/L	continuously
	> 50°C	Consult REHAU	
Chlorine Dioxide ClO ₂	Max. 60°C	Max. 0.2 mg/L ClO ₂	4 months

Table 8-3 Chemical disinfection with finite period



Chemical and thermal disinfection procedures when carried out incorrectly can lead to permanent damage to drinking water installation components.

Prior to commencing such procedures, it needs to be ensured that all parts of the installation system are thermally and chemically suitable for the corresponding measure. If necessary, have this approved by the disinfectant's manufacturer.

With thermal disinfection, it is important that the appropriate measures be taken to ensure that people are not scalded.

When carrying out discontinuous chemical disinfection it must be guaranteed that water is not used for human consumption (e.g. as drinking water) at any time during the disinfection phase, including the subsequent flushing/rinsing phase.

The safety advice from the disinfectant manufacturers must be observed.

8.7 Rainwater application



Pipe identification

EDGE™ green pipes are clearly identified as rainwater plumbing pipes by its special green outer coating and the marking "RAINWATER" as required by AS/NZS 3500 regulation.

System integration

For applications where rainwater is also used for drinking water, the local council or water authority may have imposed special restrictions regarding water treatment and compliance with the Australian Guidelines for Drinking Water. Conduct a careful check on the local requirements before contacting REHAU with regard to the suitability of EDGE™ green for this application.

System installation

Installation must be carried out by a licensed plumber, adhering to the requirements of AS/NZS 3500 and that of the local water provider.

The installation of filters or screens on tank inlets and outlets is recommended to protect the appliances and the rainwater plumbing system from becoming clogged with sludge from sediments and organic materials.



Periodically check the pH level of tank water and ensure a pH level of 6.5 to 9 is maintained. This can be done by e.g. fitting a suitable inline filter system at the tank outlet. Recommended hardness; 3-14° dH (53 - 250 ppm CaCO₃). Do not add kerosene into the rainwater tank for mosquito control as this can have an adverse effect on your tank and the polymer piping.

System maintenance

Guidelines on rainwater tanks from your local authority should be observed.

Rainwater varies in its chemical composition with the geographical location and aggressive water can accelerate wear and tear on metal components of the system.

- Periodically check the pH level of tank water and ensure a pH level of 6.5 to 9 is maintained.
- Do not add kerosene into the rainwater tank for mosquito control as this can have an adverse effect on your tank and the polymer piping.

8.8 Recycled water application



Pipe identification

EDGE™ lilac pipes are clearly identified as recycled water plumbing pipes by its special lilac outer coating and the marking "RECYCLED OR RECLAIMED - WATER - DO NOT DRINK" as required by AS/NZS 3500 regulation.

System installation

Installation must be carried out by a licensed plumber, adhering to the requirements of AS/NZS 3500 and that of the local water provider.

System limitations and water quality

The main application for EDGE™ lilac plumbing systems are dual reticulation systems. Different states in Australia may have different guidelines for recycled water applications, adhere to the state-specific guidelines.

EDGE™ lilac system shall only be used with highly treated recycled/reclaimed water (Class A and higher) and dual reticulation system. EDGE™ lilac system is not suitable for use with Class B - D treated recycled/reclaimed water and direct untreated water reuse on domestic dwellings.

Typical applications for Class A recycled/reclaimed water are:

- Residential (non-potable)
- Garden watering
- Toilet flushing
- Car washing
- Irrigation food crops to be consumed raw
- Municipal with uncontrolled public access
- Primary contact recreation

Corrosive water can accelerate wear and tear on metal components of the system. Refer to chapter 8 for specific water quality requirements to prevent corrosion in EDGE™ system.

In some cases, the available water quality may void the REHAU warranty unless appropriate water treatment is provided.

09 Pressure testing and commissioning

9.1 Water services flushing and pressure test

9.1.1 Flushing and pressure test

A visual check shall be carried out prior to pressure testing to ensure all compression sleeve joints have been secured completely.

Flushing of the system shall occur prior to and after pressure testing.

Flushing and pressure testing may be conducted in accordance with AS/NZS 3500, or by following the REHAU recommendations below.



The successful execution and documentation of a pressure test is a prerequisite for any warranty claims from REHAU.

Notes

The temperature difference between the pipe and test medium may influence the pressure test and may give false readings. A temperature change of 10°C corresponds approximately to a pressure change of 0.5 to 1 bar (50 to 100 kPa). For this reason, every effort should be made to ensure that the temperature of the test medium remains constant during the pressure test.

In this context, it is important to carry out a visual inspection of all joints while the pressure test is in progress, since experience has shown that minor leakages cannot always be detected simply by monitoring the pressure gauge.

9.1.2 REHAU Pressure test with water

The REHAU recommended pressure test procedure is an alternative solution to the requirements as described in AS/NZS 3500.

General requirements and notes:

- Conduct the pressure test on the completed but not yet concealed piping before commissioning.
- During pressure test, conduct a visual check of all unconcealed pipe work as the system's leak-tightness can't be derived from the pressure fluctuation (constant, decreasing, increasing) alone.
- Subdividing the piping system into smaller test sections may increase the test accuracy.

Preparation

1. Piping shall be accessible and not be concealed.
2. Dismount safety devices and meters as necessary and replace with pipes or pipe stoppers.
3. Fill the piping system from the lowest point with filtered drinking water and purge all air. Ensure all outlets are closed.
4. Connect the pressure testing equipment at the lowest point on the drinking water installation. The measurement precision shall be 100 hPa (0.1 bar) or better.
5. During pressure test, ensure temperature fluctuations are kept to a minimum.

Pressure test for installations with EDGE™ PE-Xa pipes

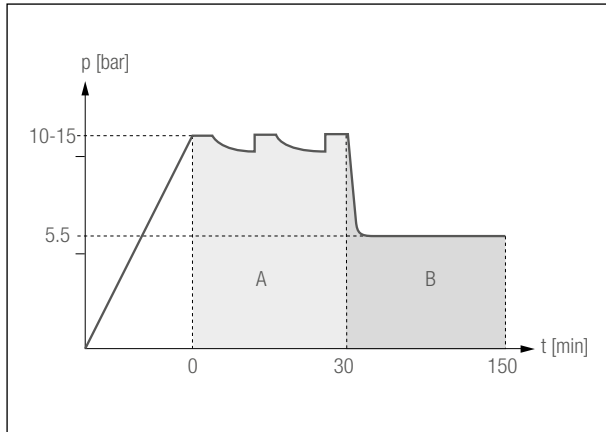

Fig. 9-1 Pressure test diagram

- A Adaptation time (if necessary restore the pressure)
 B Pressure test for installations with EDGE™ PE-Xa and installations with EDGE™ PE-Xa pipes mixed with metal pipes

1. Determine an initial test pressure "X" between 10 and 15 bar (1,000 - 1,500 kPa).
2. Slowly build up test pressure to "X" bar.
3. Maintain initial test pressure "X" during the 30 minute adjustment period.
4. Perform a initial visual inspection on all joints and pipe work for leaks.
5. Slowly decrease the test pressure from the initial test pressure "X" bar to 5.5 bar (550 kPa).
6. Perform a second visual check.
7. Record pressure in the piping system after a test period of 2 hours.

If test pressure has fallen:

- Repeat visual inspection of the installation, outlets and joints.
- After resolving the cause of the drop in pressure, repeat steps 1 - 6.

Completion of REHAU pressure test with water

1. Fill and sign pressure test protocol
2. Detach the pressure test equipment.
3. Thoroughly flush and empty the drinking water pipes for hygiene purposes
4. Reinstall all removed safety devices and meters.

9.1.3 REHAU Pressure test with air

The REHAU recommended pressure test procedure is an alternative solution to the requirements as described in AS/NZS 3500.

Important information on tests with pressurised air and inert gas:

- Use only oil free pressurised air or inert gas.
- Small leaks may only be detected using leak detection agents at high test pressures (load test) and visual inspection.
- Temperature fluctuations may affect the test result (pressure loss or increase).
- Pressurised air and inert gas are compressed gases. This means that the piping volume has a lot of influence on the shown pressure result. A high piping volume reduces the determination of small leaks using pressure reduction.



Leak detection agents

Only use leak detection agents (e.g. foaming agents) with current DVGW certification, which are also approved by the for PVDF materials.

General requirements and notes:

- Conduct the pressure test on the completed but not yet concealed piping before commissioning.
- During pressure test, conduct a visual check of all unconcealed pipe work as the system's leak-tightness can't be derived from the pressure fluctuation (constant, decreasing, increasing) alone.
- Subdividing the piping system into smaller test sections may increase the test accuracy.

Preparation

1. Piping shall be accessible and not be concealed.
2. Dismount safety devices and meters as necessary and replace with pipes or pipe stoppers.
3. Install air purges in appropriated locations to allow a safe drain after completion of the test. Ensure all outlets are closed.
4. Connect the pressure testing equipment. The measurement precision shall be 1 hPa (1 mbar) or better.
5. During pressure test, ensure temperature fluctuations are kept to a minimum.

Pressure test with air step 1 – leak test

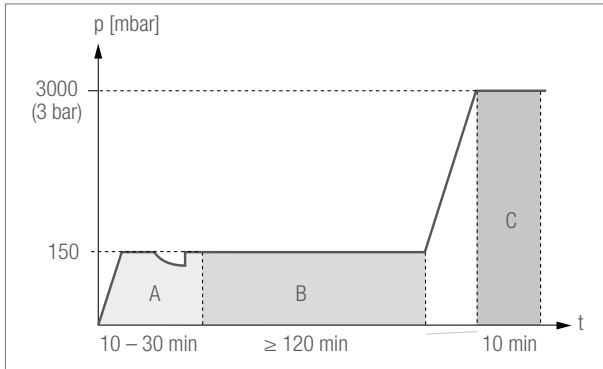

Fig 9-2 Pressure test diagram for with pressure air or inert gas

- A Adaptation time, see table below
- B Leak test
- C Load test

Pipe volume	Adaption time ¹⁾	Test time ¹⁾
< 100 l	10 min	120 min
≥ 100 < 200 l	30 min	140 min
≥ 200 l	60 min	+ 20 min per 100 l

¹⁾Approximate values, depending on the piping volume

Tab 9-1 Pipe volume, adaptation time time and test time

1. Slowly build up the test pressure to 150 mbar in the piping system.
2. Let the adaptation time (refer to Tab. 9-1) pass. If necessary restore the test pressure.
3. During the pressure test, perform a visual check on all joints and pipe work using a suitable leak detection agent
4. Record pressure in the piping system after the test time (refer to Tab. 9-1).

If the test pressure has fallen:

- Repeat visual inspection of the installation, outlets and joints.
 - After resolving the cause of the drop in pressure, repeat steps 1 - 5.
5. Pressure test is complete once the visual inspection confirms no leaks.
 6. Test protocol is found in Appendix A8.

Pressure test with air step 2 – load test

1. Slowly build up the test pressure to 3 bar (300 kPa) in the piping system.
2. If necessary, restore the test pressure after the pressure has stabilised.
3. During the pressure test, perform a visual check of all joints and pipe work using a suitable leak detection agent

4. Record pressure in the piping system after 10 minutes. If the test pressure has fallen:
 - Repeat visual inspection of the installation, outlets and joints.
 - After resolving the cause of the drop in pressure, repeat steps 1 - 5.
5. Pressure test is complete once the visual inspection confirms no leaks.
6. Test protocol is found in Appendix A8.
7. Securely drain the air out of the pipe system.

Completion of REHAU pressure test with air

1. Fill and sign pressure test protocol in Appendix A8.
2. Detach the pressure test equipment.
3. Thoroughly flush and empty the drinking water pipes for hygiene purposes (see chapter 9.1.4).
4. Reinstall all removed safety devices and meters.

In sub-zero conditions or if the drinking water installation is commissioned at a later stage, thoroughly drain all pipe work for hygienic reasons. Repeat flushing the pipe system before commissioning, or periodically if water stays in the pipe system for longer periods.

9.1.4 Purging and commissioning

Before commissioning the drinking water system, dirt from the construction phase has to be flushed out:

1. Open all outlets in sequential order and for several minutes.
2. If purging with drinking water alone is not efficient or if coarse dirt is visible in the piping system, it is recommended to purge the system alternating with water and pressurised air for several minutes or until all dirt has been flushed out. If the drinking water system won't be operated immediately after commissioning, it is recommended to completely drain the drinking water lines for hygiene purpose. Purge the drained system thoroughly before recommissioning.
3. If water has to stay in the piping a long time before the system is put into operation, purging of the installation has to be periodically repeated for hygiene reasons.
4. In sub-zero conditions it is recommended to completely drain the drinking water lines to avoid freezing. Purge the drained system thoroughly before commissioning.

10 Fire safety

The Building Codes of Australia and New Zealand both stipulate that service penetrations must not reduce the fire resistance level/rating of the building element they penetrate.

In Australia, the verification requirements for service penetrations are specified in the National Construction Code (NCC) Vol. 1 under Specification C 3.15 "Penetrations of walls, floors and ceilings by services".

The approved Document for New Zealand Building Code Fire Safety Clause C lists - under Paragraph 6.17 and Appendix C 6.1 - the requirement tests to prove a selected combination of the fire stop and pipe achieve the required fire resistance rating.

Applicable test methods are detailed in AS 1530.4 (methods for fire tests on building materials, components and structures – Part 4: Fire-resistant tests of elements of building construction).

Every service penetration reacts differently in the event of fire. As this is the case, test results are only applicable to the tested wall or floor construction, installed pipes and the applied fire stops.

A fire safety engineer responsible for a particular building can, at their discretion, accept test results from a different setup, if they deem the construction in question to be achieving a better fire rating than the one that was tested.

REHAU recommends to only use the fire protection methods which have been specifically tested with the EDGE™ pipe system. REHAU cannot accept responsibility or liability for the correct manufacture or installation of fire protection systems.

§ When planning and assembling fireproof collars, the requirements of the general building construction approval and the specifications of the assembly instructions must be observed. When using fireproof collars, the applicable national regulations must be observed.

The following passive fire protection manufacturers may have approved solutions. Please enquire directly to confirm.

Promat
(1800 PROMAT or 1800 776 628 or www.promat.com.au)

Hilti
(131 292 or www.hilti.com.au)

Contact the manufacturer of the fire collar for information on fire test results and assembly/installation instructions to determine which solution suits your requirements.

PRESSURE LOSS TABLES FOR REHAU EDGE™

Cold water at 25°C

Peak Flow Rate Qs (L/s) (0.01 to 0.5)	PN16		PN16		PN16		PN16	
	16 x 2		20 x 2.3		25 x 2.8		32 x 3.6	
	D _o (mm) = 16 D _i (mm) = 12		D _o (mm) = 20 D _i (mm) = 15.4		D _o (mm) = 25 D _i (mm) = 19.4		D _o (mm) = 32 D _i (mm) = 24.8	
	Head Loss (kPa/m)	Velocity (m/s)	Head Loss (kPa/m)	Velocity (m/s)	Head Loss (kPa/m)	Velocity (m/s)	Head Loss (kPa/m)	Velocity (m/s)
0.01	0.0193	0.088	0.0060	0.054	0.0021	0.034	0.0007	0.021
0.02	0.0615	0.177	0.0191	0.107	0.0065	0.068	0.0021	0.041
0.03	0.1226	0.265	0.0378	0.161	0.0128	0.101	0.0040	0.062
0.04	0.2008	0.354	0.0617	0.215	0.0208	0.135	0.0066	0.083
0.05	0.2952	0.442	0.0905	0.268	0.0304	0.169	0.0096	0.104
0.06	0.4051	0.531	0.1238	0.322	0.0415	0.203	0.0130	0.124
0.07	0.5300	0.619	0.1617	0.376	0.0541	0.237	0.0170	0.145
0.08	0.6695	0.707	0.2038	0.429	0.0681	0.271	0.0213	0.166
0.09	0.8233	0.796	0.2502	0.483	0.0835	0.304	0.0261	0.186
0.10	0.9911	0.884	0.3007	0.537	0.1002	0.338	0.0313	0.207
0.11	1.1727	0.973	0.3553	0.591	0.1183	0.372	0.0369	0.228
0.12	1.3679	1.061	0.4139	0.644	0.1376	0.406	0.0429	0.248
0.13	1.5765	1.149	0.4764	0.698	0.1583	0.440	0.0493	0.269
0.14	1.7984	1.238	0.5428	0.752	0.1801	0.474	0.0560	0.290
0.15	2.0334	1.326	0.6130	0.805	0.2033	0.507	0.0631	0.311
0.16	2.2815	1.415	0.6871	0.859	0.2276	0.541	0.0707	0.331
0.17	2.5425	1.503	0.7649	0.913	0.2532	0.575	0.0785	0.352
0.18	2.8164	1.592	0.8464	0.966	0.2799	0.609	0.0868	0.373
0.19	3.1030	1.680	0.9316	1.020	0.3079	0.643	0.0954	0.393
0.20	3.4022	1.768	1.0205	1.074	0.3370	0.677	0.1043	0.414
0.21	3.7141	1.857	1.1130	1.127	0.3673	0.710	0.1136	0.435
0.22	4.0384	1.945	1.2091	1.181	0.3988	0.744	0.1233	0.455
0.23	4.3753	2.034	1.3088	1.235	0.4314	0.778	0.1333	0.476
0.24	4.7245	2.122	1.4122	1.288	0.4651	0.812	0.1436	0.497
0.25	5.0862	2.210	1.5190	1.342	0.5000	0.846	0.1543	0.518
0.26	5.4601	2.299	1.6294	1.396	0.5360	0.880	0.1653	0.538
0.27	5.8463	2.387	1.7433	1.450	0.5732	0.913	0.1767	0.559
0.28	6.2447	2.476	1.8607	1.503	0.6114	0.947	0.1884	0.580
0.29	6.6552	2.564	1.9816	1.557	0.6508	0.981	0.2004	0.600
0.30	7.0780	2.653	2.1060	1.611	0.6913	1.015	0.2128	0.621
0.31	7.5128	2.741	2.2338	1.664	0.7329	1.049	0.2255	0.642
0.32	7.9597	2.829	2.3651	1.718	0.7755	1.083	0.2385	0.662
0.33	8.4186	2.918	2.4998	1.772	0.8193	1.116	0.2519	0.683
0.34	8.8896	3.006	2.6379	1.825	0.8641	1.150	0.2655	0.704
0.35	9.3725	3.095	2.7795	1.879	0.9100	1.184	0.2795	0.725
0.36	9.8674	3.183	2.9244	1.933	0.9570	1.218	0.2938	0.745
0.37	10.3742	3.272	3.0728	1.986	1.0051	1.252	0.3085	0.766
0.38	10.8930	3.360	3.2245	2.040	1.0542	1.286	0.3234	0.787
0.39	11.4236	3.448	3.3796	2.094	1.1045	1.319	0.3387	0.807
0.40	11.9661	3.537	3.5380	2.147	1.1557	1.353	0.3543	0.828
0.41	12.5204	3.625	3.6998	2.201	1.2080	1.387	0.3702	0.849
0.42	13.0865	3.714	3.8650	2.255	1.2614	1.421	0.3864	0.869
0.43	13.6645	3.802	4.0334	2.309	1.3159	1.455	0.4029	0.890
0.44	14.2542	3.890	4.2053	2.362	1.3713	1.489	0.4197	0.911
0.45	14.8558	3.979	4.3804	2.416	1.4279	1.522	0.4369	0.932
0.46	15.4690	4.067	4.5589	2.470	1.4854	1.556	0.4543	0.952
0.47	16.0940	4.156	4.7406	2.523	1.5441	1.590	0.4721	0.973
0.48	16.7308	4.244	4.9257	2.577	1.6037	1.624	0.4902	0.994
0.49	17.3792	4.333	5.1141	2.631	1.6644	1.658	0.5085	1.014
0.50	18.0393	4.421	5.3058	2.684	1.7261	1.692	0.5272	1.035

PRESSURE LOSS TABLES FOR REHAU EDGE™

Cold water at 25°C

Peak Flow Rate Qs (L/s) (0.51 to 1.0)	PN16		PN16		PN16		PN16	
	16 x 2		20 x 2.3		25 x 2.8		32 x 3.6	
	D _o (mm) = 16 D _i (mm) = 12		D _o (mm) = 20 D _i (mm) = 15.4		D _o (mm) = 25 D _i (mm) = 19.4		D _o (mm) = 32 D _i (mm) = 24.8	
	Head Loss (kPa/m)	Velocity (m/s)	Head Loss (kPa/m)	Velocity (m/s)	Head Loss (kPa/m)	Velocity (m/s)	Head Loss (kPa/m)	Velocity (m/s)
0.51	18.7112	4.509	5.5007	2.738	1.7889	1.725	0.5462	1.056
0.52	19.3947	4.598	5.6989	2.792	1.8527	1.759	0.5655	1.076
0.53	20.0898	4.686	5.9005	2.845	1.9175	1.793	0.5851	1.097
0.54	20.7966	4.775	6.1052	2.899	1.9833	1.827	0.6050	1.118
0.55	21.5150	4.863	6.3133	2.953	2.0501	1.861	0.6252	1.139
0.56	22.2451	4.951	6.5246	3.006	2.1180	1.895	0.6457	1.159
0.57	22.9867	5.040	6.7392	3.060	2.1869	1.928	0.6665	1.180
0.58	23.7400	5.128	6.9570	3.114	2.2568	1.962	0.6876	1.201
0.59	24.5049	5.217	7.1781	3.168	2.3278	1.996	0.7090	1.221
0.60	25.2813	5.305	7.4024	3.221	2.3997	2.030	0.7307	1.242
0.61	26.0694	5.394	7.6299	3.275	2.4726	2.064	0.7527	1.263
0.62	26.8690	5.482	7.8607	3.329	2.5466	2.097	0.7749	1.284
0.63	27.6801	5.570	8.0947	3.382	2.6216	2.131	0.7975	1.304
0.64	28.5028	5.659	8.3320	3.436	2.6975	2.165	0.8204	1.325
0.65	29.3371	5.747	8.5725	3.490	2.7745	2.199	0.8436	1.346
0.66	30.1828	5.836	8.8162	3.543	2.8525	2.233	0.8671	1.366
0.67	31.0402	5.924	9.0631	3.597	2.9315	2.267	0.8908	1.387
0.68	31.9090	6.013	9.3132	3.651	3.0115	2.300	0.9149	1.408
0.69	32.7893	6.101	9.5666	3.704	3.0925	2.334	0.9392	1.428
0.70	33.6812	6.189	9.8231	3.758	3.1744	2.368	0.9639	1.449
0.71	34.5846	6.278	10.0829	3.812	3.2574	2.402	0.9888	1.470
0.72	35.4994	6.366	10.3458	3.865	3.3414	2.436	1.0140	1.491
0.73	36.4258	6.455	10.6120	3.919	3.4264	2.470	1.0396	1.511
0.74	37.3636	6.543	10.8813	3.973	3.5123	2.503	1.0654	1.532
0.75	38.3129	6.631	11.1539	4.027	3.5993	2.537	1.0915	1.553
0.76	39.2737	6.720	11.4297	4.080	3.6872	2.571	1.1178	1.573
0.77	40.2459	6.808	11.7086	4.134	3.7761	2.605	1.1445	1.594
0.78	41.2296	6.897	11.9907	4.188	3.8661	2.639	1.1715	1.615
0.79	42.2248	6.985	12.2760	4.241	3.9570	2.673	1.1987	1.635
0.80	43.2314	7.074	12.5645	4.295	4.0489	2.706	1.2263	1.656
0.81	44.2495	7.162	12.8562	4.349	4.1417	2.740	1.2541	1.677
0.82	45.2790	7.250	13.1510	4.402	4.2356	2.774	1.2822	1.698
0.83	46.3199	7.339	13.4491	4.456	4.3305	2.808	1.3106	1.718
0.84	47.3723	7.427	13.7503	4.510	4.4263	2.842	1.3393	1.739
0.85	48.4361	7.516	14.0546	4.563	4.5231	2.876	1.3683	1.760
0.86	49.5114	7.604	14.3622	4.617	4.6209	2.909	1.3976	1.780
0.87	50.5980	7.692	14.6729	4.671	4.7196	2.943	1.4271	1.801
0.88	51.6961	7.781	14.9867	4.724	4.8194	2.977	1.4569	1.822
0.89	52.8056	7.869	15.3038	4.778	4.9201	3.011	1.4870	1.842
0.90	53.9265	7.958	15.6240	4.832	5.0218	3.045	1.5174	1.863
0.91	55.0588	8.046	15.9473	4.886	5.1245	3.079	1.5481	1.884
0.92	56.2026	8.135	16.2739	4.939	5.2281	3.112	1.5791	1.905
0.93	57.3577	8.223	16.6035	4.993	5.3327	3.146	1.6103	1.925
0.94	58.5242	8.311	16.9364	5.047	5.4383	3.180	1.6419	1.946
0.95	59.7021	8.400	17.2723	5.100	5.5449	3.214	1.6737	1.967
0.96	60.8914	8.488	17.6115	5.154	5.6525	3.248	1.7058	1.987
0.97	62.0921	8.577	17.9538	5.208	5.7610	3.282	1.7381	2.008
0.98	63.3042	8.665	18.2992	5.261	5.8704	3.315	1.7708	2.029
0.99	64.5276	8.754	18.6478	5.315	5.9809	3.349	1.8037	2.049
1.00	65.7624	8.842	18.9995	5.369	6.0923	3.383	1.8370	2.070

PRESSURE LOSS TABLES FOR REHAU EDGE™

Hot water at 60°C

Peak Flow Rate Qs (L/s) (0.01 to 0.5)	PN16		PN16		PN16		PN16	
	16 x 2		20 x 2.3		25 x 2.8		32 x 3.6	
	D _o (mm) = 16 D _i (mm) = 12		D _o (mm) = 20 D _i (mm) = 15.4		D _o (mm) = 25 D _i (mm) = 19.4		D _o (mm) = 32 D _i (mm) = 24.8	
	Head Loss (kPa/m)	Velocity (m/s)	Head Loss (kPa/m)	Velocity (m/s)	Head Loss (kPa/m)	Velocity (m/s)	Head Loss (kPa/m)	Velocity (m/s)
0.01	0.0154	0.088	0.0048	0.054	0.0016	0.034	0.0005	0.021
0.02	0.0502	0.177	0.0155	0.107	0.0052	0.068	0.0016	0.041
0.03	0.1012	0.265	0.0310	0.161	0.0104	0.101	0.0033	0.062
0.04	0.1672	0.354	0.0510	0.215	0.0170	0.135	0.0053	0.083
0.05	0.2474	0.442	0.0751	0.268	0.0251	0.169	0.0078	0.104
0.06	0.3413	0.531	0.1034	0.322	0.0344	0.203	0.0107	0.124
0.07	0.4486	0.619	0.1355	0.376	0.0450	0.237	0.0140	0.145
0.08	0.5689	0.707	0.1715	0.429	0.0568	0.271	0.0177	0.166
0.09	0.7020	0.796	0.2112	0.483	0.0699	0.304	0.0217	0.186
0.10	0.8478	0.884	0.2546	0.537	0.0841	0.338	0.0261	0.207
0.11	1.0061	0.973	0.3015	0.591	0.0995	0.372	0.0308	0.228
0.12	1.1768	1.061	0.3521	0.644	0.1161	0.406	0.0359	0.248
0.13	1.3597	1.149	0.4062	0.698	0.1337	0.440	0.0413	0.269
0.14	1.5548	1.238	0.4638	0.752	0.1525	0.474	0.0470	0.290
0.15	1.7619	1.326	0.5248	0.805	0.1724	0.507	0.0531	0.311
0.16	1.9810	1.415	0.5893	0.859	0.1934	0.541	0.0595	0.331
0.17	2.2120	1.503	0.6572	0.913	0.2155	0.575	0.0663	0.352
0.18	2.4549	1.592	0.7284	0.966	0.2386	0.609	0.0733	0.373
0.19	2.7097	1.680	0.8031	1.020	0.2628	0.643	0.0807	0.393
0.20	2.9761	1.768	0.8810	1.074	0.2881	0.677	0.0884	0.414
0.21	3.2543	1.857	0.9623	1.127	0.3144	0.710	0.0964	0.435
0.22	3.5442	1.945	1.0469	1.181	0.3417	0.744	0.1047	0.455
0.23	3.8458	2.034	1.1348	1.235	0.3701	0.778	0.1133	0.476
0.24	4.1589	2.122	1.2260	1.288	0.3995	0.812	0.1222	0.497
0.25	4.4836	2.210	1.3204	1.342	0.4300	0.846	0.1315	0.518
0.26	4.8199	2.299	1.4181	1.396	0.4615	0.880	0.1410	0.538
0.27	5.1677	2.387	1.5191	1.450	0.4940	0.913	0.1508	0.559
0.28	5.5270	2.476	1.6232	1.503	0.5275	0.947	0.1609	0.580
0.29	5.8978	2.564	1.7306	1.557	0.5620	0.981	0.1714	0.600
0.30	6.2801	2.653	1.8413	1.611	0.5975	1.015	0.1821	0.621
0.31	6.6738	2.741	1.9551	1.664	0.6341	1.049	0.1931	0.642
0.32	7.0789	2.829	2.0721	1.718	0.6716	1.083	0.2044	0.662
0.33	7.4954	2.918	2.1923	1.772	0.7101	1.116	0.2161	0.683
0.34	7.9233	3.006	2.3157	1.825	0.7496	1.150	0.2280	0.704
0.35	8.3626	3.095	2.4423	1.879	0.7901	1.184	0.2401	0.725
0.36	8.8133	3.183	2.5721	1.933	0.8316	1.218	0.2526	0.745
0.37	9.2753	3.272	2.7050	1.986	0.8741	1.252	0.2654	0.766
0.38	9.7486	3.360	2.8411	2.040	0.9176	1.286	0.2785	0.787
0.39	10.2333	3.448	2.9803	2.094	0.9620	1.319	0.2918	0.807
0.40	10.7293	3.537	3.1227	2.147	1.0074	1.353	0.3054	0.828
0.41	11.2366	3.625	3.2682	2.201	1.0538	1.387	0.3193	0.849
0.42	11.7552	3.714	3.4169	2.255	1.1012	1.421	0.3335	0.869
0.43	12.2851	3.802	3.5687	2.309	1.1495	1.455	0.3480	0.890
0.44	12.8263	3.890	3.7236	2.362	1.1988	1.489	0.3628	0.911
0.45	13.3787	3.979	3.8817	2.416	1.2491	1.522	0.3778	0.932
0.46	13.9424	4.067	4.0429	2.470	1.3004	1.556	0.3932	0.952
0.47	14.5174	4.156	4.2072	2.523	1.3526	1.590	0.4088	0.973
0.48	15.1036	4.244	4.3746	2.577	1.4057	1.624	0.4247	0.994
0.49	15.7011	4.333	4.5452	2.631	1.4599	1.658	0.4408	1.014
0.50	16.3098	4.421	4.7188	2.684	1.5150	1.692	0.4573	1.035

PRESSURE LOSS TABLES FOR REHAU EDGE™

Hot water at 60°C

Peak Flow Rate Qs (L/s) (0.51 to 1.0)	PN16		PN16		PN16		PN16	
	16 x 2		20 x 2.3		25 x 2.8		32 x 3.6	
	D _o (mm) = 16 D _i (mm) = 12		D _o (mm) = 20 D _i (mm) = 15.4		D _o (mm) = 25 D _i (mm) = 19.4		D _o (mm) = 32 D _i (mm) = 24.8	
	Head Loss (kPa/m)	Velocity (m/s)	Head Loss (kPa/m)	Velocity (m/s)	Head Loss (kPa/m)	Velocity (m/s)	Head Loss (kPa/m)	Velocity (m/s)
0.51	16.9297	4.509	4.8956	2.738	1.5710	1.725	0.4740	1.056
0.52	17.5609	4.598	5.0755	2.792	1.6280	1.759	0.4910	1.076
0.53	18.2033	4.686	5.2584	2.845	1.6860	1.793	0.5083	1.097
0.54	18.8568	4.775	5.4445	2.899	1.7449	1.827	0.5259	1.118
0.55	19.5216	4.863	5.6337	2.953	1.8047	1.861	0.5437	1.139
0.56	20.1977	4.951	5.8259	3.006	1.8656	1.895	0.5618	1.159
0.57	20.8849	5.040	6.0213	3.060	1.9273	1.928	0.5802	1.180
0.58	21.5833	5.128	6.2197	3.114	1.9901	1.962	0.5989	1.201
0.59	22.2929	5.217	6.4212	3.168	2.0537	1.996	0.6178	1.221
0.60	23.0137	5.305	6.6259	3.221	2.1183	2.030	0.6370	1.242
0.61	23.7456	5.394	6.8336	3.275	2.1839	2.064	0.6565	1.263
0.62	24.4888	5.482	7.0443	3.329	2.2504	2.097	0.6762	1.284
0.63	25.2431	5.570	7.2582	3.382	2.3179	2.131	0.6963	1.304
0.64	26.0086	5.659	7.4751	3.436	2.3863	2.165	0.7166	1.325
0.65	26.7853	5.747	7.6951	3.490	2.4556	2.199	0.7371	1.346
0.66	27.5732	5.836	7.9182	3.543	2.5259	2.233	0.7580	1.366
0.67	28.3722	5.924	8.1444	3.597	2.5971	2.267	0.7791	1.387
0.68	29.1824	6.013	8.3736	3.651	2.6693	2.300	0.8005	1.408
0.69	30.0037	6.101	8.6059	3.704	2.7424	2.334	0.8221	1.428
0.70	30.8362	6.189	8.8413	3.758	2.8164	2.368	0.8440	1.449
0.71	31.6798	6.278	9.0797	3.812	2.8914	2.402	0.8662	1.470
0.72	32.5346	6.366	9.3212	3.865	2.9673	2.436	0.8887	1.491
0.73	33.4006	6.455	9.5657	3.919	3.0441	2.470	0.9114	1.511
0.74	34.2777	6.543	9.8134	3.973	3.1219	2.503	0.9344	1.532
0.75	35.1659	6.631	10.0640	4.027	3.2006	2.537	0.9577	1.553
0.76	36.0653	6.720	10.3178	4.080	3.2803	2.571	0.9812	1.573
0.77	36.9758	6.808	10.5746	4.134	3.3609	2.605	1.0051	1.594
0.78	37.8975	6.897	10.8344	4.188	3.4424	2.639	1.0291	1.615
0.79	38.8303	6.985	11.0973	4.241	3.5249	2.673	1.0535	1.635
0.80	39.7743	7.074	11.3633	4.295	3.6082	2.706	1.0781	1.656
0.81	40.7293	7.162	11.6323	4.349	3.6926	2.740	1.1030	1.677
0.82	41.6955	7.250	11.9044	4.402	3.7778	2.774	1.1281	1.698
0.83	42.6729	7.339	12.1795	4.456	3.8640	2.808	1.1535	1.718
0.84	43.6613	7.427	12.4577	4.510	3.9511	2.842	1.1792	1.739
0.85	44.6609	7.516	12.7389	4.563	4.0391	2.876	1.2051	1.760
0.86	45.6717	7.604	13.0232	4.617	4.1281	2.909	1.2313	1.780
0.87	46.6935	7.692	13.3105	4.671	4.2180	2.943	1.2578	1.801
0.88	47.7265	7.781	13.6009	4.724	4.3088	2.977	1.2845	1.822
0.89	48.7706	7.869	13.8943	4.778	4.4006	3.011	1.3115	1.842
0.90	49.8258	7.958	14.1908	4.832	4.4932	3.045	1.3388	1.863
0.91	50.8921	8.046	14.4903	4.886	4.5868	3.079	1.3663	1.884
0.92	51.9696	8.135	14.7929	4.939	4.6814	3.112	1.3941	1.905
0.93	53.0581	8.223	15.0984	4.993	4.7768	3.146	1.4222	1.925
0.94	54.1578	8.311	15.4071	5.047	4.8732	3.180	1.4505	1.946
0.95	55.2686	8.400	15.7188	5.100	4.9705	3.214	1.4791	1.967
0.96	56.3905	8.488	16.0335	5.154	5.0687	3.248	1.5080	1.987
0.97	57.5235	8.577	16.3512	5.208	5.1679	3.282	1.5371	2.008
0.98	58.6677	8.665	16.6721	5.261	5.2680	3.315	1.5665	2.029
0.99	59.8229	8.754	16.9959	5.315	5.3690	3.349	1.5961	2.049
1.00	60.9893	8.842	17.3228	5.369	5.4709	3.383	1.6260	2.070

REHAU Pty Ltd – National Customer Service Centre

Suite 1.02, Level 1, Quad 1, 8 Parkview Drive,
Sydney Olympic Park, NSW 2127

AUSTRALIA

Tel: 1300 768 033

Fax: 1300 760 665

Email: sales.au@rehau.com

www.rehau.com.au



The information contained herein is believed to be reliable, but no representations, guarantees or warranties of any kind are made as to its accuracy, suitability for particular applications or the results to be obtained therefrom. Before using, the user will determine suitability of the information for user's intended use and shall assume all risk and liability in connection therewith.