

PRODUCT SUBMITTAL 2405

REHAU F1960 LF Brass Copper Press 90° Male Elbows



Product: REHAU F1960 LF Brass Copper Press 90° Elbows

Date: 20 March 2024

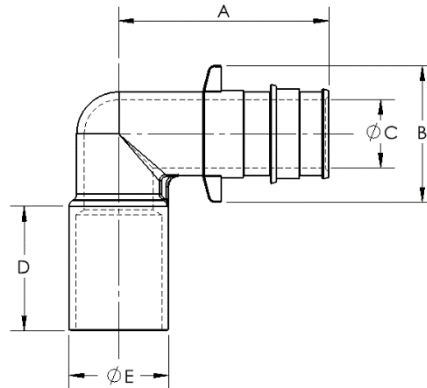

Article No.	Nominal Size in.	A in. (mm)	B in. (mm)	C in. (mm)	D in. (mm)	E in. (mm)
499294-001	1/2 x 1/2 in. Copper Male Press	1.40 (35.56)	0.85 (21.59)	0.378 (9.60)	0.93 (23.62)	0.62 (15.75)
499279-001	3/4 x 3/4 in. Copper Male Press	1.85 (46.99)	1.20 (30.48)	0.595 (15.11)	1.09 (27.69)	0.87 (22.10)

TECHNICAL DESCRIPTION

Specification	ASTM F1960 / CSA B137.5
Material	ECO BRASS® (C69300 or CW724R)
Certifications	cNSFus-pw

FUNCTIONAL DESCRIPTION

REHAU F1960 cold expansion fittings and rings are intended for use with REHAU PEXa pipes. The maximum temperature and pressure ratings of the REHAU F1960 fitting system is in accordance with ASTM F877 and CSA B137.5 for SDR9 PEX, see REHAU pipe product submittals for ratings. Installation is performed with commercially available F1960 cold expansion tools. Follow all published REHAU Technical Guidelines. All REHAU F1960 fittings and rings comply with the lead-free (LF) requirements of the U.S. Safe Drinking Water Act.

For updates to this publication, visit na.rehau.com/resourcecenter

The information contained herein is believed to be reliable, but no representations, guarantees or warranties of any kind are made as to its accuracy, suitability for particular applications or the results to be obtained therefrom. Before using, the user will determine suitability of the information for user's intended use and shall assume all risk and liability

© 2024 REHAU in connection therewith.