

---

# FIREPEX<sup>®</sup> RESIDENTIAL FIRE SPRINKLER SYSTEM

## Design and Installation Guide

---



# CONTENTS

<b>1. Scope</b>	<b>3</b>	<b>6. System Planning</b>	<b>21</b>
		6.1 Determine Local Jurisdiction Requirements	21
<b>2. Design &amp; Applications</b>	<b>4</b>	6.2 Obtain Residence Information	21
2.1 Applications	4	6.3 Identify Water Supply Source, Flow, Pressure	21
2.2 Types of Fire Sprinkler Systems	4	6.4 Determine Layout of Water Supply	22
2.3 Piping Configurations	5	6.5 Determine Sprinkler Requirements	22
2.4 Design Considerations	6	6.6 Design Piping System Layout	23
		6.7 Perform Hydraulic Calculations	23
<b>3. System Overview</b>	<b>7</b>	6.8 Obtain AHJ Approval	23
3.1 Application	7	<b>7. Installation Considerations</b>	<b>24</b>
3.2 Standards and Certifications	7	7.1 Ensuring Design Meets Installation Guidelines	24
3.3 Warranty	7	7.2 Mounting FIREPEX Sprinkler Fittings	24
<b>4. RAUPEX PEXa Pipe</b>	<b>8</b>	7.3 RAUPEX Pipe Packaging	28
4.1 Pipe Properties	8	7.4 EVERLOC+ Fittings Packaging	28
4.2 Pipe Dimensions and Weights	8	7.5 Uncoiling Pipe	28
4.3 Pipe Markings	8	7.6 Bending Pipe	28
4.4 Pressure and Temperature Ratings	9	7.7 Distance Between Fittings	29
4.5 Excessive Temperature and Pressure Capability	9	7.8 Pipe Protection	29
4.6 Corrosion Resistance	9	7.9 Supporting RAUPEX Pipe	30
4.7 Chlorine Resistance	9	7.10 Supporting EVERLOC+ Fittings	30
4.8 Ultraviolet Resistance	9	7.11 Copper Soldering	30
4.9 Bend Radius	10	7.12 Kink Repair	31
4.10 Chemical Compatibility	10	7.13 Installing Sprinklers	31
4.11 Freeze Break Resistance	10	7.14 Pressure Testing	31
4.12 Condensation	10	7.15 Testing System Flow	32
		7.16 Maintaining the System	33
<b>5. EVERLOC+ Compression-sleeve Fittings</b>	<b>11</b>		
5.1 Fitting Scope	11		
5.2 Fitting Assembly	14		
5.3 Installation Considerations	14		
5.4 EVERLOC+ Compression-sleeve Tools	17		
5.5 Fire Sprinklers	19		



For updates to this publication and the most current technical instructions, safety information and manufacturer's recommendations, visit [www.na.rehau.com/resourcecenter](http://www.na.rehau.com/resourcecenter)

# 1. SCOPE

**This technical information applies to the REHAU FIREPEX® residential fire sprinkler system including the assembly and use of the EVERLOC+® compression-sleeve fittings, RAUPEX® white UV shield (PEXa pipe) and EVERLOC+ compression-sleeve tools, intended for use in residential fire sprinkler systems.**

For professional use only. Persons using this guide must be experienced and appropriately licensed fire sprinkler system designers or installers, who have an understanding of the principles and practices for system design and installation.

The information presented in this guide is intended to demonstrate the proper design, assembly method and installation recommendations for the FIREPEX system but is not specific to your project conditions. It is the responsibility of the licensed professional to check the prevailing local codes and to verify that technical information presented in this guide is appropriate for a particular installation.



Nothing in this guide supersedes national or local code requirements or the recommendations of other manufacturers regarding their components. Observe all applicable national, state and local laws, regulations, standards codes and ordinances. If you believe REHAU product information conflicts with applicable code requirements, industry standards, or the recommendations of other manufacturers regarding their components, contact the REHAU distributor in your area and consult with the building authority having jurisdiction before installing the FIREPEX system.

Before starting the design process, read the REHAU *PEXa Limited Warranty*, available at [www.na.rehau.com/warranties](http://www.na.rehau.com/warranties). It can also be obtained from your authorized REHAU distributor or by writing to REHAU Construction LLC, 1501 Edwards Ferry Road NE, Leesburg VA 20176 US.

Proper installation is the responsibility of the installing contractor. Review the REHAU *Technical Guidelines* prior to installation of the FIREPEX system. REHAU *Technical Guidelines* are defined in the REHAU *PEXa Limited Warranty* as: The most current and applicable versions of all the technical literature available on the REHAU North America website at [www.na.rehau.com/resourcecenter](http://www.na.rehau.com/resourcecenter), including, but not limited to, technical manuals, instruction guides, technical bulletins, submittals and REHAU Academy training presentations. Check the REHAU Resource Center for the latest updates ([www.na.rehau.com/resourcecenter](http://www.na.rehau.com/resourcecenter)).

Contact the REHAU distributor in your area if you do not understand the information in this manual or if you have questions about the REHAU *Technical Guidelines*.

This guide contains safety-related information that requires your special attention. It is indicated with the safety alert symbol and the signal words described below:

 <b>DANGER</b>	Indicates a hazardous situation which, if not avoided, will result in death or serious injury.
 <b>WARNING</b>	Indicates a hazardous situation which, if not avoided, could result in death or serious injury.
 <b>CAUTION</b>	Indicates a hazardous situation which, if not avoided, could result in minor or moderate injury.
<b>NOTICE</b>	Indicates a risk of property damage

Only trained personnel should be engaged in the installation process. Follow the instructions in this guide and other REHAU *Technical Guidelines* and use common sense to reduce the risk of injury or property damage.

## **WARNING**



Read the instruction manual for the EVERLOC+ compression-sleeve tools before use and follow all safety precautions — improper use can cause serious personal injury.

## **WARNING**



EVERLOC+ compression-sleeve tools use a strong hydraulic force to expand PEXa pipe and compress components of the REHAU EVERLOC+ compression-sleeve system.

To reduce the risk of crush and laceration injury, keep fingers, hands and all parts of your body away from the expander head, hydraulic slide and compression jaws during operation. Remove the battery before attempting to change or adjust the expander head or compression jaws.

DEWALT® and the DEWALT logo are trademarks of Stanley Black & Decker, Inc., or an affiliate thereof and are used under license.

MAKITA® is a trademark of Makita Corporation, or an affiliate thereof.



# 2. DESIGN & APPLICATIONS

## 2.1 Applications

The FIREPEX residential fire sprinkler system serves the requirements for fire sprinkler systems as defined by National Fire Protection Association (NFPA) *Standard 13D Installation of Sprinkler Systems in One- and Two-Family Dwellings and Manufactured Homes* and the *International Residential Code Section (IRC) P2904*.

The purpose of NFPA 13D and IRC P2904 is to provide a sprinkler system that aids in the detection and control of residential fires, thus offering improved protection against injury and loss of life. A sprinkler system that is designed and installed in accordance with this standard is expected to prevent flashover (total involvement of the fire) in the room of fire origin, where sprinklered, and to improve the chance for occupants to escape or be evacuated.

RAUPEX white UV shield pipe and EVERLOC+ fittings are approved for use in residential fire sprinkler systems as defined by NFPA 13D and IRC P2904 for a variety of residential applications including single- or two-family homes, town homes, modular homes and manufactured housing.



Fig. 2.1: FIREPEX installation

## 2.2 Types of Fire Sprinkler Systems

The NFPA 13D standard categorizes all fire sprinkler systems within two general types: wet pipe systems and dry pipe systems.

- Wet pipe systems are filled with water and installed in areas not subject to freezing.
- Dry pipe systems are not filled with water, and can be located in unheated areas subject to freezing.

### The FIREPEX system is for wet pipe systems only.

Within the wet pipe systems, NFPA 13D defines the layout of systems under the following types, for which the FIREPEX system can be installed:

- Multipurpose Sprinkler System
- Passive Purge Sprinkler System
- Stand-alone Sprinkler System

### 2.2.1 Multipurpose Sprinkler Systems

Multipurpose systems are defined in NFPA 13D and IRC P2904 as a piping system intended to serve both fire sprinklers and domestic plumbing needs. A multipurpose system integrates the piping connected to a water supply with sprinklers that automatically discharge water over a fire area. All piping in a multipurpose system supplying sprinklers must be listed or conform to the piping specifications in NFPA 13D or IRC P2904.

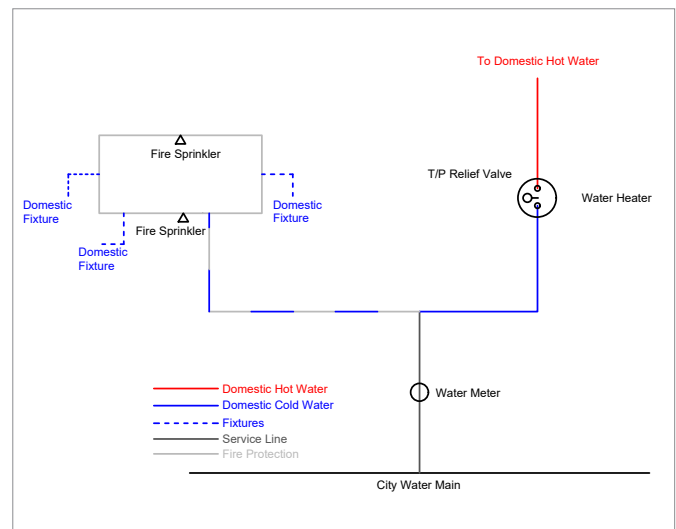

Fig. 2.2: Multipurpose system

### 2.2.2 Passive Purge Sprinkler System

A passive purge system is defined in NFPA 13D as a type of sprinkler system that serves a single toilet in addition to the sprinkler system.

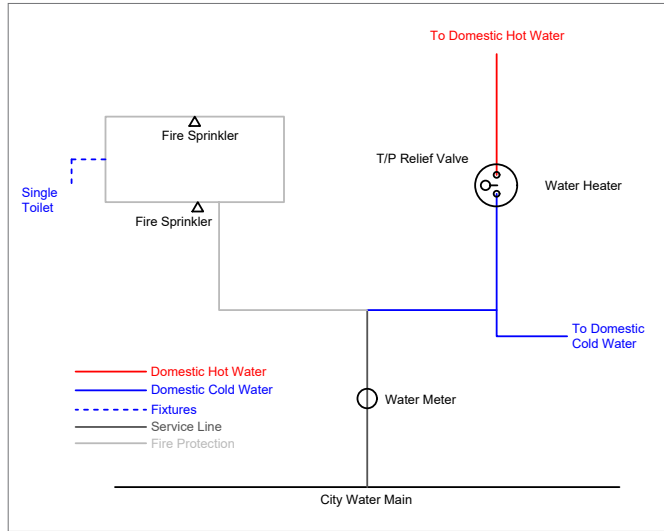

Fig. 2.3: Passive purge system

### 2.2.3 Stand-alone Sprinkler System

A stand-alone system is defined in NFPA 13D as a type of sprinkler system where the above ground piping serves only fire sprinklers.

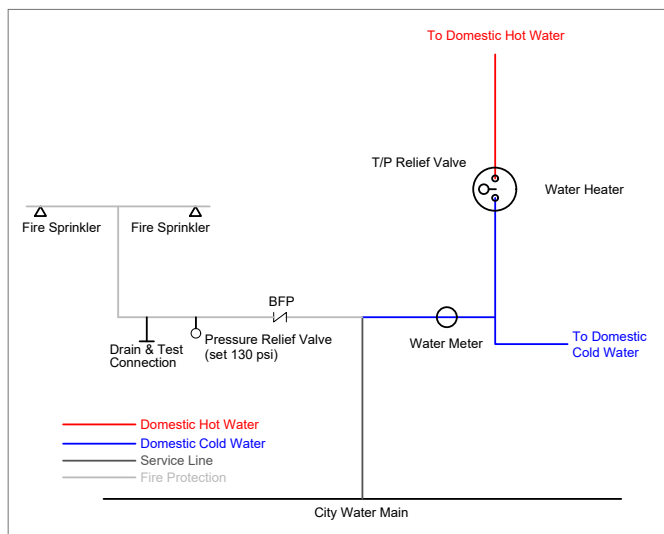

Fig. 2.4: Stand-alone system

## NOTICE

These drawings represent design intent and concept only. This technical information is not intended to be used as final drawings or specifications. It is provided only as an aid in designers' development of the final specification and is not intended as a substitute for sound judgment.

### 2.3 Piping Configurations

The NFPA 13D standard defines three types of piping systems that are allowed to be used in residential occupancies stating that piping configurations shall be permitted to be gridded, looped or straight-run, or to be combinations thereof.

Of the three aforementioned configurations:

- Gridded systems provide the highest level of hydraulic characteristics for pressure/flow calculations.
- Looped systems provide hydraulic characteristics better than straight-run systems, but not as good as gridded systems.
- Straight-run system provide the lowest level of hydraulic characteristics.

#### 2.3.1 Gridded System

A gridded system is a sprinkler system connected by multiple branch lines. An activated sprinkler will be provided with water from both sides, while other branch lines help transfer the water.

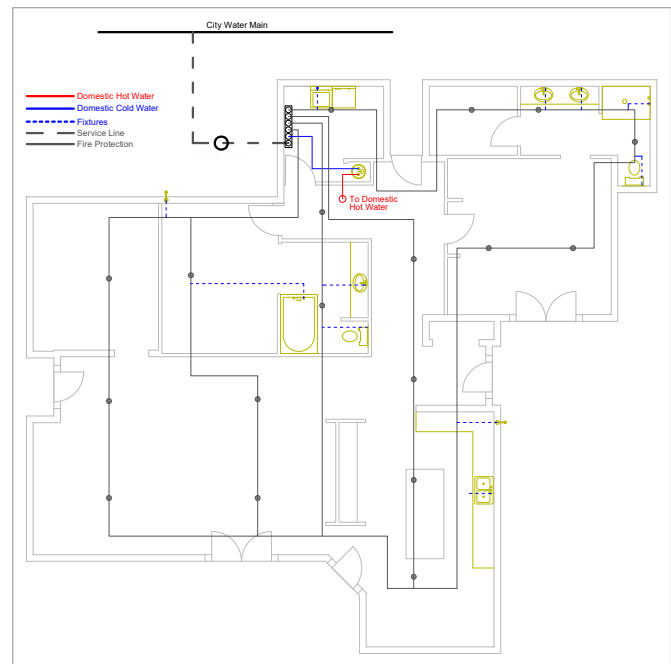

Fig. 2.5: Gridded system layout

### 2.3.2 Looped System

A looped system is a sprinkler system where multiple cross mains are connected, but the branch lines are not.

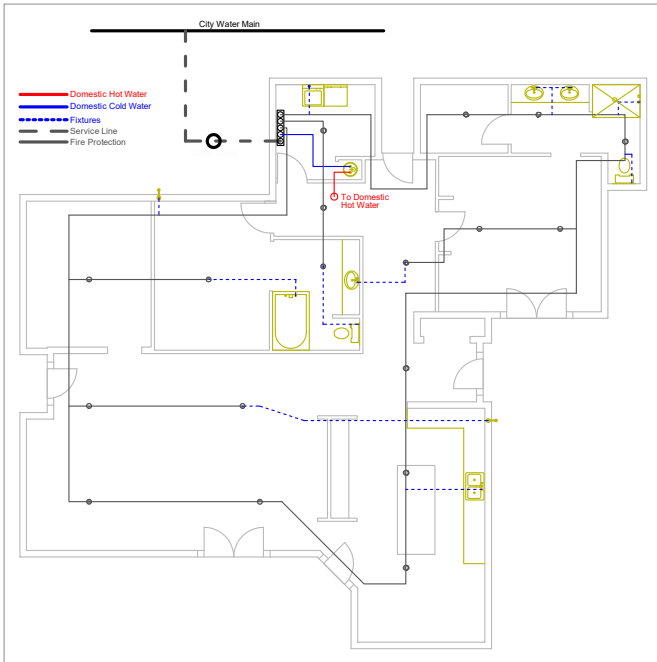

Fig. 2.6: Looped system layout

### 2.3.3 Straight-run System

A straight-run system, also known as a tree-type system, is a sprinkler system in which each sprinkler is served by only one water flow path.

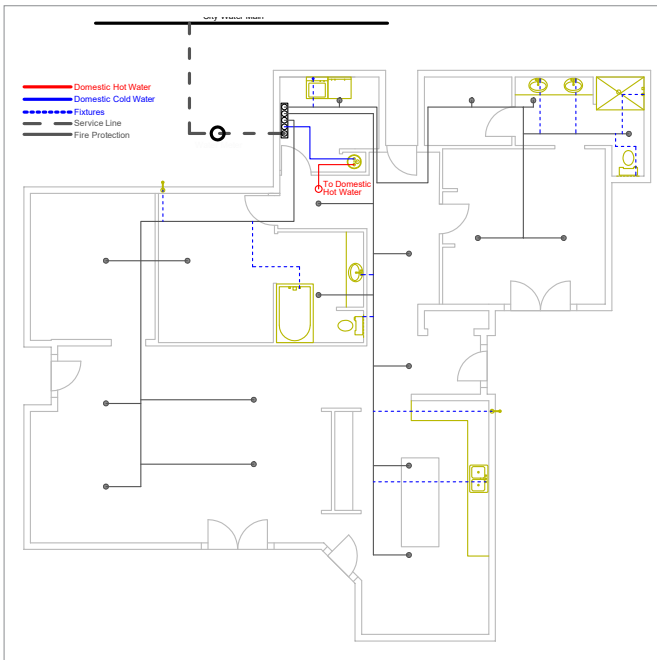

Fig. 2.7: Straight-run system layout

### 2.4 Design Considerations

The critical points in design of an NFPA 13D and IRC P2904 sprinkler system are:

- Identify local jurisdiction requirements, including determination of pertinent building, fire protection and plumbing codes.
- Obtain residence characteristics.
- Identify the water supply source and available flow in GPM and supply pressure in psi.
- Identify the water supply service line including elevation difference between connections and routing of the service line into the residence.
- Determine the specifications for the sprinklers including water flow and operating pressure requirements and coverage area specifications.
- Lay out the piping system in the residence as a looped, gridded or straight-run system as defined by NFPA 13D.
- Lay out the piping system for cold and hot water distribution.
- Perform the hydraulic calculations on the system to determine system performance.
- Coordinate fire sprinkler installation with other building trades to minimize installation/scheduling conflicts. Verify installation of sprinkler system per plan (includes sprinkler locations and proper mounting height).
- When the fire sprinkler system connects to plumbing fixtures it is required to comply with prevailing local plumbing codes.

### NOTICE

The FIREPEX system shall not have a fire department connection and the static pressure of the system shall be limited to 80 psi. If the static pressure of the water supply is not less than 80 psi, a pressure reducing valve set no higher than 80 psi shall be used. When a pressure reducing valve is required, an automatic means of pressure relief shall be installed on the sprinkler system side of the pressure reducing valve.

# 3. SYSTEM OVERVIEW

## 3.1 Application

The FIREPEX residential fire sprinkler system includes RAUPEX white UV shield (PEXa) pipe, EVERLOC+ polymer and lead-free brass fittings, PEXa compression sleeves and EVERLOC+ compression-sleeve tools.

The EVERLOC+ compression-sleeve fitting system is a cold-expansion PEXa fitting system available in polymer and lead-free (LF) brass, assembled with a specially designed PEXa compression sleeve. The fittings are designed specifically for use with RAUPEX pipe and must only be assembled with EVERLOC+ compression-sleeve tools.



Fig. 3.1: RAUPEX white UV shield crosslinked polyethylene (PEXa) pipe



Fig 3.2: EVERLOC+ compression-sleeve fittings and PEXa compression sleeves



Fig. 3.3: EVERLOC+ compression-sleeve tools

## 3.2 Standards and Certifications

RAUPEX white UV shield pipes are certified for use in residential fire sprinkler systems as defined by NFPA 13D or IRC P2904.

RAUPEX red and blue UV shield are not certified for fire sprinkler systems.

The FIREPEX system is third-party certified by NSF International ([www.nsf.org](http://www.nsf.org)) to the following standards:

- UL 1821 Standard for Thermoplastic Sprinkler Pipe and Fittings for Fire Protection Service
- ASTM F877 Standard Specification for Crosslinked Polyethylene (PEX) Hot- and Cold-Water Distribution Systems
- CSA B137.5 Crosslinked Polyethylene (PEX) Tubing Systems for Pressure Applications
- NSF/ANSI 14 Plastic Piping System Components and Related Materials
- NSF/ANSI 61 Drinking Water System Components and Related Materials
- NSF/ANSI 372 Drinking Water System Components – Lead Content (complies with the lead-free requirements of the U.S. Safe Drinking Water Act)

## 3.3 Warranty

RAUPEX UV shield pipe and EVERLOC+ compression-sleeve fittings and sleeves are backed by a 25-year limited warranty. EVERLOC+ compression-sleeve tools are backed by a 2-year limited warranty. REHAU offers this warranty when the installation is carried out in accordance with the requirements outlined in the REHAU *PEXa Warranty 855.018*, which is available as a separate document at [www.na.rehau.com/warranties](http://www.na.rehau.com/warranties).

# 4. RAUPEX PEXa PIPE

## 4.1 Pipe Properties

Crosslinked polyethylene is polyethylene (PE) which has undergone a change in molecular structure whereby the polymer chains are chemically linked, crosslinked (X), with each other to form a three-dimensional network. The result is a flexible thermoset polymer with improved mechanical, thermal and chemical properties.

There are three methods of manufacturing PEX:

- The peroxide method (PEXa), ASTM requires a minimum of 70% crosslinking
- The silane method (PEXb), ASTM requires a minimum of 65% crosslinking
- The radiation method (PEXc), ASTM requires a minimum of 65% crosslinking

RAUPEX pipe is manufactured using the peroxide method (PEXa), which yields the highest, most consistent level of crosslinking. PEXa technology enhances flexibility and thermal memory, providing ease of handling and kink repair compared to PEXb and PEXc.

PEXa has distinct advantages over other polymer and metal pipes:

- Resists pitting and stress corrosion
- Resists scaling and deposit build-up when used with both hard and softened water
- Minimizes noise that is transmitted through pipes
- Resists notching and abrasion damage

RAUPEX is manufactured by REHAU in a facility whose quality management system is ISO 9001 certified. In addition, RAUPEX production is independently monitored annually by NSF International, CSA Group and Underwriters Laboratories Inc. (UL).

**Table 4.1: RAUPEX Properties**

Specification	English	SI	Standard
Minimum Density	58 lb/ft <sup>3</sup>	926 kg/m <sup>3</sup>	ASTM F876
Minimum Degree of Crosslinking	70%	70%	ASTM F876
Max Thermal Conductivity	2.84 Btu in/(ft <sup>2</sup> ·F·hr)	0.41 W/(m·K)	DIN 16892
Coefficient of Linear Expansion	9.33 x 10 <sup>-4</sup> in/ft °F @68°F 1.33 x 10 <sup>-3</sup> in/ft °F @212°F	0.14 mm/(m°C) @20°C 0.2 mm/(m°C) @100°C	Mean @ 20-70°C per DIN 16892
Modulus of Elasticity	87,000-130,500 psi @ 68°F 43,500-58,000 psi @176°F	600-900 N/mm <sup>2</sup> @20°C 300-400 N/mm <sup>2</sup> @80°C	Minimum @ 20°C per DIN 16892

Specification	English	SI	Standard
Tensile Strength	4194-4355 psi @68°F 2610-2900 psi @176°F per ASTM D638	26-30 N/mm <sup>2</sup> @20°C 18-20 N/mm <sup>2</sup> @80°C per ASTM D638	--
IZOD Impact Resistance	No Break	No Break	--
Roughness	e=0.00028 in.	e =0.007 mm	--
Temperature Working Range	-40 to 200°F	-40 to 93°C	--
Maximum Short-term Exposure	150 psig @ 210°F (48 hr)	1035 kPa @ 99°C (48 hr)	ASTM F876
UV Resistance	See TB218		ASTM 2657

## 4.2 Pipe Dimensions and Weights

RAUPEX white UV shield pipe for residential fire sprinkler systems is available in nominal sizes ranging from 3/4 to 2 in., and is in accordance to the dimensional standards defined in ASTM F876 and CSA B137.5. RAUPEX is copper tube size (CTS) outside diameter (OD), which means that the actual OD of the pipe is 1/8 in (3.18 mm) larger than the nominal size.

Wall thickness is defined by the standard dimensional ratio (SDR). RAUPEX UV shield pipe is SDR9, which equates to the outside diameter being approximately nine times the wall thickness. Since PEX pipe has a thicker wall than copper tube, the inside diameter (ID) is slightly smaller. However, since PEX pipe is not susceptible to the erosion and corrosion issues of copper tube, systems can be designed at higher velocities which allow for comparable sizing of a system.

**Table 4.2: RAUPEX White UV Shield Pipe Dimensions and Weights**

Pipe Size	Average OD in (mm)	Min Wall Thickness in (mm)	Weight lb/ft (kg/m)
3/4 in	0.875 (22.22)	0.097 (2.47)	0.10 (0.15)
1 in	1.125 (28.58)	0.125 (3.18)	0.17 (0.26)
1 1/4 in	1.375 (34.92)	0.153 (3.88)	0.25 (0.37)
1 1/2 in	1.625 (41.28)	0.181 (4.59)	0.35 (0.52)
2 in	2.125 (53.98)	0.236 (6.00)	0.60 (0.90)

## 4.3 Pipe Markings

RAUPEX pipe markings are repeated every 3 ft (0.9 m), list all certifications and approvals, and include an incremental footage marking to assist with installation.



### 4.3.1 PEX Designation Code

RAUPEX pipe is further identified with a PEX Material Designation code in accordance to ASTM F876. The PEX Designation Code is the abbreviation for the material - PEX - followed by four numerals.

The PEX Designation Code for RAUPEX white UV shield pipe is

**PEX 3306**

The first numeral **(3)** refers to the chlorine resistance in one of four categories, when tested in accordance with ASTM Test Method F2023 and evaluated in accordance with ASTM F876. This measurement indicates the allowable hours of 140°F water recirculation in 1 day.

<b>0 = none</b>	<b>1 = 4 hours</b> <small>e.g., 25% of lifetime</small>	<b>3 = 12 hours</b> <small>e.g., 50% of lifetime</small>	<b>5 = 24 hours</b> <small>e.g., 100% of lifetime</small>
-----------------	--	---	--

The second numeral **(3)** refers to UV resistance in one of four categories, when tested in accordance with ASTM Test Method F2657 and evaluated in accordance with ASTM F876. The measurement indicates the allowable time pipe can be exposed to UV without being compromised.

<b>0 = none</b>	<b>1 = 1 month</b>	<b>2 = 3 months</b>	<b>3 = 6 months</b>
-----------------	--------------------	---------------------	---------------------

The third and fourth numerals **(06)** refer to the Hydrostatic Design Stress for water at 73°F in hundreds of psi. The standard pressure rating at 73°F is derived from this measurement.

**06 = 630 psi**

### 4.4 Pressure and Temperature Ratings

The maximum temperature and pressure ratings of RAUPEX pipe are in accordance to ASTM F876, CSA B137.5 and PPI TR-3. The designer shall determine the actual conditions and apply the appropriate and additional design factors as required for any particular project.

According to the REHAU *PEXa Limited Warranty*, the RAUPEX pipe warranty period is for operating conditions at or below 180°F (82.2°C) in permitted applications when the handling, use, installation and maintenance continually complies with all REHAU *Technical Guidelines*.

**Table 4.3: RAUPEX White UV Shield Pressure and Temperature Ratings**

RAUPEX White UV Shield Pipe	
Maximum Pressures and Temperatures	Design Factors
160 psi @ 73.4°F (1055 kPa @ 23°C)	0.50 (per ASTM F876, CSA B137.5)
130 psi @ 120°F (900 kPa @ 49°C)	0.50 (per ASTM F876, CSA B137.5)
100 psi @ 180°F (690 kPa @ 82.2°C)	0.50 (per ASTM F876, CSA B137.5)

### 4.5 Excessive Temperature and Pressure Capability

Temperature and pressure (T&P) relief valves are safety mechanisms in case the system overheats (mandatory in hot water distribution systems). These valves act quickly to relieve excess temperature or pressure if either one of these conditions is reached. In the event of a water heating system failure or T&P relief valve failure, RAUPEX pipe has been tested to accommodate short-term exposure conditions of 210°F (99°C) at 150 psi (10 bar) for 48 hours.

### NOTICE

Failure to follow pressure and temperature limits may damage the pipe resulting in leaks and operational failures, and will negate any warranty provided by REHAU for RAUPEX pipes. The designer must incorporate proper controls into the system to ensure the pressure and temperature capability of the pipe is not exceeded.

### 4.6 Corrosion Resistance

RAUPEX pipe is non-reactive and displays excellent corrosion resistance. Corrosion is a process that requires electrically conductive materials and occurs on metals. PEXa, being a dielectric, does not corrode like metal pipes. PEXa also resists the buildup of scale which is common with copper pipe.

### 4.7 Chlorine Resistance

RAUPEX pipe has been tested in accordance with ASTM F2023, *Standard Test Method for Evaluating the Oxidative Resistance of Crosslinked Polyethylene (PEX) Tubing and Systems to Hot Chlorinated Water* as required in ASTM F876. RAUPEX pipe exceeds the minimum extrapolated test lifetime as certified by NSF for cold water applications, intermittent hot water applications and timed hot water applications.

This recommendation applies to RAUPEX white UV shield pipes for cold water and intermittent hot water applications (25% @ 140°F, 75% @ 73°F) and for timed hot water recirculation systems for up to 12 hours per day (50% @ 140°F, 50% @ 73°F). The ASTM F876 standard includes designation codes for these applications which are included on the print line of RAUPEX pipes.

### 4.8 Ultraviolet Resistance

All polymers are susceptible to damage from exposure to the ultraviolet (UV) radiation in sunlight. PEX pipes can be designed to protect against short-term UV damage, but after some time, UV radiation will reduce the lifetime of the pipe. The extent of the reduction depends on factors such as temperature, pressure and chlorination levels in potable water. Excessive UV exposure will reduce the lifetime of the PEXa pipe.

REHAU has performed extensive testing of RAUPEX pipes exposed to UV, leading to the maximum UV exposure times expressed in accumulated days. Once the pipes leave the manufacturing plant, any exposure to UV, including transportation and storage, is part of the accumulated exposure time.

Although ASTM F876 only categorizes up to 6 months of UV resistance (Material Designation Code = 3306), REHAU has tested and certified RAUPEX white UV shield pipe according to ASTM F2657 for the following maximum UV exposure period:

- RAUPEX white UV shield pipe: Maximum exposure time of one year accumulated

RAUPEX pipes must be kept in the original packaging until the time of installation. RAUPEX must not be stored outdoors and is not designed for permanent outdoor exposure (with the exception of non-exposed buried applications).

## NOTICE

Failure to follow maximum UV exposure limits may damage the pipe resulting in leaks and operational failures, and will negate any warranty provided by REHAU for RAUPEX pipes.

### 4.9 Bend Radius

RAUPEX pipe may be bent, even when cold. REHAU support bends can assist to create tight bends without kinking. The typical bend radius used by the installer is 8X the OD. The minimum bend radius is 5X the OD for cold bends. For an even smaller bend radius, the pipe may be heated with a heat gun and bent to no less than 3X the OD. If a tighter bend radius is required, the designer should consider using a smaller diameter pipe.

Table 4.4: RAUPEX Bend Radius

Pipe Size	Bend Radius in (mm)		
	Typical 8X OD	Min. Cold 5X OD	Min. Heated 3X OD
3/4 in	7.0 (178)	4.375 (111)	2.625 (67)
1 in	9.0 (229)	5.625 (143)	3.375 (86)
1 1/4 in	11.0 (279)	6.875 (175)	4.125 (105)
1 1/2 in	13.0 (330)	--	--
2 in	17.0 (432)	--	--

### 4.10 Chemical Compatibility

While RAUPEX pipes are resistant to many chemicals that are used in typical residential fire sprinkler applications, there are some chemicals that may damage the pipe.

Chemicals that may be damaging include (but are not limited to):

- Adhesives
- Oil or petroleum-based products
- Paints
- Solvents
- Oxidizing agents
- Disinfectants
- PVC glues
- Solvents and cements

Many factors, such as exposure time, temperature, pressure and other operating parameters, can influence the performance of a pipe that is exposed to a chemical. To determine the impact of a particular chemical, short- and long-term pressure testing may be required. In some cases, a pipe may be resistant to short-term exposure to the chemical, but not resistant to continuous exposure. Each chemical must be evaluated individually. It is the responsibility of the installing contractor to verify chemical compatibility of any chemicals that may come into contact with the polymer material.

### 4.11 Freeze Break Resistance

The flexibility of the RAUPEX pipe allows it to expand as water freezes in the pipe as long as the pipe has room to expand. When the water thaws, the pipe returns to its original shape. If the pipe is not allowed to expand (e.g., it is encased in concrete), it may burst.

## NOTICE

Designers and installers must take precautions as per the guidelines defined in NFPA 13D to ensure that pipes do not freeze. Frozen pipes may burst resulting in leaks and operational failures.

### 4.12 Condensation

Condensation occurs on pipes when the surface temperature is lower than the dew point of the environment. This is typically a problem for metallic cold water piping. PEX pipe has lower thermal conductivity (0.41 W/m<sup>2</sup>K) than copper (401 W/m<sup>2</sup>K) resulting in less heat loss to the surface and greater resistance to condensation or sweating.

# 5. EVERLOC+ COMPRESSION-SLEEVE FITTINGS

## 5.1 Fitting Scope

The EVERLOC+ compression-sleeve system is a cold-expansion PEXa fitting system that is available in polymer and lead-free (LF) brass and is assembled with a specially designed PEXa compression sleeve. The fitting is designed specifically for use with RAUPEX pipe and must only be assembled with the EVERLOC+ compression-sleeve tools.

EVERLOC+ fittings for residential fire sprinkler applications are available in 3/4 to 2 in. sizes and are listed for use with RAUPEX white UV shield pipe (3/4 to 2 in.) manufactured in accordance with ASTM F876.

For a detailed description of the REHAU system components, refer to the REHAU *Building Solutions Product Catalog (855.312)*.

### 5.1.1 Fitting Features

EVERLOC+ polymer and lead-free (LF) brass fittings have the following features:

1. Four sealing edges
2. Pipe stop
3. Fitting collar
4. Tool jaw body



Fig. 5.1: EVERLOC+ fitting features

### 5.1.2 Fitting and Sleeve Markings

All polymer fittings include the following marks for identification



Fig. 5.2: Fitting size marking (e.g., 3/4")



Fig. 5.3: Batch code (e.g., production date)

All LF brass fittings are marked "REHAU"

All sleeves include the following marks for identification

**REHAU**

- Sleeve size (e.g., 3/4")
- Batch code for production date



Fig. 5.4: Sleeve markings

### 5.1.3 Polymer Fittings

EVERLOC+ polymer fittings are available in couplings, tees, elbows, multi-port tees and plugs. All polymer fittings are produced from a polyphenylsulfone (PPSU) material. See also REHAU *Technical Bulletin TB265 EVERLOC+ Polymer Fitting Material - PPSU*.

### 5.1.4 Lead Free (LF) Brass Fittings

EVERLOC+ LF brass fittings are available as couplings, tees, elbows, plugs and transition fittings to NPT thread and copper solder connections. All metal fittings are produced from ECO BRASS® (UNS 69300 or CW 724R). See also REHAU *Technical Bulletin TB264 EVERLOC+ Lead-free Brass Fitting Material*.



Fig. 5.5: EVERLOC+ polymer and LF brass fittings

### 5.1.5 PEXa Compression Sleeves

EVERLOC+ compression sleeves are produced using a specially formulated PEXa material and are designed specifically for use with EVERLOC+ fittings and RAUPEX pipe. EVERLOC+ compression sleeves have the following features:

- Co-extruded platinum-colored PE coating
- Squarely cut ends that can be slid over the pipe in either direction
- Grooved and roughened inside surface for locking the sleeve into place once slid over the pipe and fitting



Fig. 5.6: EVERLOC+ PEXa compression sleeves

### 5.1.6 Certifications

The EVERLOC+ compression-sleeve fitting system is certified to the following standards:

- UL 1821 Standard for Thermoplastic Sprinkler Pipe and Fittings for Fire Protection Service
- ASTM F877, Standard Specification for Crosslinked Polyethylene (PEX) Hot- and Cold-Water Distribution Systems
- NSF/ANSI 14, Plastic Piping System Components and Related Materials
- NSF/ANSI 61, Drinking Water System Components – Health Effects
- NSF/ANSI 372, Drinking Water System Components – Lead Content
- CSA B137.5, Crosslinked polyethylene (PEX) Tubing Systems for Pressure Applications



### 5.1.7 Equivalent Length of Fittings

It is common practice for designers to convert the pressure drop across fittings to an average equivalent length of pipe. These equivalent lengths are added to the total pipe length. Designers can calculate total pressure loss using this adjusted piping system length.

**Table 5.1: Equivalent Length of Fittings Couplings**

Fitting Description	Equivalent Length (ft)
3/4 x 3/4 in. EVERLOC+ Polymer Coupling	0.8
1 x 3/4 in. EVERLOC+ Polymer Coupling	2.7
1 x 1 in. EVERLOC+ Polymer Coupling	1.1
1 1/4 x 1 in. EVERLOC+ Polymer Coupling	4.0
1 1/4 x 1 1/4 in. EVERLOC+ Polymer Coupling	2.0
1 1/2 x 1 in. EVERLOC+ Polymer Coupling	4.8
1 1/2 x 1 1/2 in. EVERLOC+ Polymer Coupling	2.0
2 x 1 in. EVERLOC+ LF Brass Coupling	5.2
2 x 1 1/4 in. EVERLOC+ LF Brass Coupling	5.3
2 x 1 1/2 in. EVERLOC+ LF Brass Coupling	6.1
2 x 2 in. EVERLOC+ Polymer Coupling	2.2

### Elbows (PEX to PEX)

Fitting Description	Equivalent Length (ft)
3/4 x 3/4 in. EVERLOC+ Polymer Elbow	7.0
1 x 1 in. EVERLOC+ Polymer Elbow	10.7
1 1/4 x 1 1/4 in. EVERLOC+ Polymer Elbow	14.2
1 1/2 x 1 1/2 in. EVERLOC+ Polymer Elbow	16.0
2 x 2 in. EVERLOC+ Polymer Elbow	24.2

### Elbows (PEX to transition)

Fitting Description	Equivalent Length (ft)
3/4 x 3/4 in. C Female EVERLOC+ LF Brass Elbow	7.1
3/4 x 3/4 in. C Male EVERLOC+ LF Brass Elbow	7.4
3/4 x 3/4 in. MPT EVERLOC+ LF Brass Drop Ear Elbow	7.5

### Adapters (PEX to copper)

Fitting Description	Equivalent Length (ft)
3/4 x 1 in. C Female EVERLOC+ LF Brass Adapter	3.9
3/4 x 3/4 in. C Female EVERLOC+ LF Brass Adapter	2.7
3/4 x 3/4 in. C Male EVERLOC+ LF Brass Adapter	2.6
1 x 1 in. C Female EVERLOC+ LF Brass Adapter	3.5
1 x 1 in. C Male EVERLOC+ LF Brass Adapter	3.3
1 1/4 x 1 1/4 in. C Female EVERLOC+ LF Brass Adapter	4.1
1 1/4 x 1 1/4 in. C Male EVERLOC+ LF Brass Adapter	4.3
1 1/2 x 1 1/2 in. C Female EVERLOC+ LF Brass Adapter	5.3
1 1/2 x 1 1/2 in. C Male EVERLOC+ LF Brass Adapter	5.4
2 x 2 in. C Female EVERLOC+ LF Brass Adapter	7.0
2 x 2 in. C Male EVERLOC+ LF Brass Adapter	6.9

### Adapters (PEX to MPT/FPT)

Fitting Description	Equivalent Length (ft)
3/4 x 3/4 in. FPT EVERLOC+ LF Brass Adapter	2.8
3/4 x 3/4 in. MPT EVERLOC+ LF Brass Adapter	3.4
3/4 x 1 in. MPT EVERLOC+ LF Brass Adapter	4.3
1 x 1 in. FPT EVERLOC+ LF Brass Adapter	3.6
1 x 1 in. MPT EVERLOC+ LF Brass Adapter	3.8
1 1/4 x 1 1/4 in. MPT EVERLOC+ LF Brass Adapter	4.9
1 1/2 x 1 1/2 in. MPT EVERLOC+ LF Brass Adapter	5.9
2 x 2 in. MPT EVERLOC+ LF Brass Adapter	7.3

### Tees

Fitting Description	Equivalent Length (ft) RUN	Equivalent Length (ft) BRANCH
3/4 x 3/4 x 3/4 in. EVERLOC+ Polymer Tee	1.2	7.6
3/4 x 3/4 x 1 in. EVERLOC+ Polymer Tee	-	6.8
1 x 1 x 1/2 in. EVERLOC+ Polymer Tee	1.6	3.9
1 x 3/4 x 3/4 in. EVERLOC+ Polymer Tee	2.8	6.5
1 x 3/4 x 1 in. EVERLOC+ Polymer Tee	3.1	10.9
1 x 1 x 3/4 in. EVERLOC+ Polymer Tee	1.2	6.7
1 x 1 x 1 in. EVERLOC+ Polymer Tee	1.6	10.6
1 1/4 x 1 x 1 in. EVERLOC+ Polymer Tee	3.8	9.7
1 1/4 x 1 x 1 1/4 in. EVERLOC+ LF Brass Tee	4.3	9.6
1 1/4 x 1 1/4 x 1 in. EVERLOC+ Polymer Tee	2.3	10.1
1 1/4 x 1 1/4 x 1 1/4 in. EVERLOC+ Polymer Tee	2.2	14.4
1 1/2 x 1 x 1 in. EVERLOC+ LF Brass Tee	5.5	7.9
1 1/2 x 1 x 1 1/2 in. EVERLOC+ LF Brass Tee	5.6	12.4
1 1/2 x 1 1/4 x 1 in. EVERLOC+ LF Brass Tee	4.4	8.1
1 1/2 x 1 1/4 x 1 1/4 in. EVERLOC+ LF Brass Tee	4.5	9.5
1 1/2 x 1 1/4 x 1 1/2 in. EVERLOC+ LF Brass Tee	4.3	10.9
1 1/2 x 1 1/2 x 1 in. EVERLOC+ Polymer Tee	2.2	9.1
1 1 2 x 1 1/2 x 1 1/4 in. EVERLOC+ LF Brass Tee	1.7	9.6
1 1/2 x 1 1/2 x 1 1/2 in. EVERLOC+ Polymer Tee	2.6	17.0
2 x 1 1/4 x 2 in. EVERLOC+ LF Brass Tee	6.7	14.9
2 x 1 1/2 x 1 in. EVERLOC+ LF Brass Tee	6.2	7.7
2 x 1 1/2 x 1 1/4 in. EVERLOC+ LF Brass Tee	6.3	9.5
2 x 1 1/2 x 1 1/2 in. EVERLOC+ LF Brass Tee	6.4	11.2
2 x 1 1/2 x 2 in. EVERLOC+ LF Brass Tee	6.5	14.6
2 x 2 x 1 in. EVERLOC+ Polymer Tee	3.2	9.0
2 x 2 x 1 1/4 in. EVERLOC+ LF Brass Tee	1.9	9.7
2 x 2 x 1 1/2 in. EVERLOC+ LF Brass Tee	1.9	10.9
2 x 2 x 2 in. EVERLOC+ Polymer Tee	4.0	25.3

## 5.2 Fitting Assembly

Before starting the installation process, read the *EVERLOC+ Compression-sleeve System Product Instructions* (855.724).

Assembling the EVERLOC+ compression-sleeve system requires the use of the EVERLOC+ compression-sleeve tools. Only make EVERLOC+ compression-sleeve joints with these tools. Refer to *EVERLOC+ Power Tool Product Instruction Manual* (855.725), *EVERLOC+ XL Power Tool Product Instruction Manual* (855.728) and *EVERLOC+ XL Expander Tool Product Instruction Manual* (855.729) for a complete understanding of operation, care and use of the EVERLOC+ compression-sleeve tools.

### WARNING



Read the instruction manual for the EVERLOC+ compression-sleeve tools before use and follow all safety precautions - improper use can cause serious personal injury.

### WARNING



To reduce the risk of permanent eye injury, always wear close-fitting protective eye wear with side protection. Eye wear must be impact-rated and marked as complying with ANSI Z87.

## NOTICE

Use only EVERLOC+ compression-sleeve tools for assembly and installation. Use of other tools will result in an improperly assembled joint, which may result in leaks and property damage.

The basic process of assembling an EVERLOC+ compression-sleeve joint is as follows:

- Make a clean, square cut of the RAUPEX pipe using a RAUPEX cutter
- Slide the EVERLOC+ compression sleeve over the RAUPEX pipe ensuring the sleeve is a minimum of two times the length of the sleeve from the end of the cut pipe to allow for expansion of the pipe only
- Expand the RAUPEX pipe twice, ensuring the expander head is rotated 1/2 of one expander head segment between expansions, using the EVERLOC+ compression-sleeve tools
- Insert the EVERLOC+ compression-sleeve fitting into the expanded end of the RAUPEX pipe so that the pipe is touching the pipe stop on the fitting
- Compress the EVERLOC+ compression sleeve over the RAUPEX pipe and EVERLOC+ compression-sleeve fitting using the EVERLOC+ compression-sleeve tools

Required assembly tools include:

- RAUPEX cutter
- EVERLOC+ compression-sleeve tools
- EVERLOC+ expander heads and compression jaws

## 5.3 Installation Considerations

Some precautions and additional considerations that should be taken when installing the system.

### 5.3.1 EVERLOC+ Fitting Removal

- EVERLOC+ LF brass fittings **CAN** be reused, as long the rib area was not damaged during removal.
- EVERLOC+ polymer fittings **CANNOT** be reused and should be discarded immediately.
- EVERLOC+ compression sleeves **CANNOT** be reused and should be discarded immediately.



Fig. 5.7: DO NOT cut the EVERLOC+ compression sleeve from finished joint



Fig. 5.8: DO NOT cut RAUPEX pipe from fitting

#### 5.3.1.1 Fitting Removal of Completed Joint (LF brass ONLY)

If it is required to remove the LF brass fitting or disassemble the LF brass compression-sleeve joint, use the following procedure:

If the fitting has been inserted into the pipe and the sleeve has been compressed, safely hold the fitting while it is heated. Be careful not to damage the fitting with the tool.

1. Heat the sleeve directly using a heat gun.
2. Rotate the joint several times while heating.
3. Remove heat and use pliers to pull the sleeve off the fitting, then immediately pull the fitting out of the pipe.

## **⚠ WARNING**

- Do not use open flames to disassemble the joint. Open flames can cause injury or property damage.
- Never use a torch, open flame or heat gun on a pressurized system.
- Never rework a connection that is under pressure. Depressurize the system, cut out connection and replace.



Fig. 5.9: Heating EVERLOC+ compression sleeve with heat gun



Fig. 5.10: Removing pipe from LF brass fitting

For re-assembly of a joint, the following should be considered:

- The end of the pipe where the previous fitting had been installed must be completely cut off prior to making a new joint. Cutting off a minimum of 3 in (approximately 75 mm) is recommended.



Fig. 5.11: Cut off 3 in. of pipe from end prior to making new joint

### **5.3.1.2 Fitting Removal of Partially Completed Joint (LF Brass ONLY)**

If the fitting has been inserted into the pipe, but the sleeve has not been compressed, attempt to remove it without damaging the fitting. If fitting cannot be easily removed, heat 1 to 1 1/2 in (25 to 38 mm) of the pipe that covers the fitting and pull the fitting out of the pipe.

### **5.3.2 Protecting EVERLOC+ Joints**

REHAU permits EVERLOC+ compression-sleeve joints (polymer and LF brass) to be buried or concealed. REHAU recommends that threaded connections never be buried or concealed as they must be accessible for periodic inspection, per prevailing local codes.

The requirement to wrap an EVERLOC+ joint can depend on many factors including location and the presence of other materials that contact or can come in contact with the joint.

When wrapping an EVERLOC+ joint, the following is required:

- Wrap the joint, ensure minimum of 50% overlap of the tape
- Avoid wrinkles or kinks in the tape and ensure the joint is completely covered, extending on to the pipe as necessary
- Indicate the location of each joint as required on the “as-built” drawings



Fig. 5.12: REHAU Protective Tape, Red



Fig. 5.13: Linerless Rubber Tape, Black

Note: Use only REHAU recommended protective tapes referenced in REHAU *Technical Bulletin TB266 Protecting EVERLOC+ Joints*. Do not use other types of tapes (e.g., duct tape, standard electrical tape) to wrap the joint, as chemicals in the adhesive may not be compatible with the PPSU fitting material or the PEXa pipe.

Note: Never use heat shrink tubing (e.g., RAUCROSS) to wrap the joint, as the high temperatures produced from a heat gun will soften the pipe and may cause it to pull away from the fitting.



Fig. 5.14: DO NOT use heat shrink tubing for EVERLOC+ joints

### **5.3.2.1 Concealed in Inaccessible Locations**

When EVERLOC+ joints are concealed but are still in open air spaces (e.g., behind drywall), it is not necessary to wrap the joint. However, the installer should ensure that the fitting does not come in contact with chemicals (e.g., PVC glues, solvents and cements) that could damage the fitting material.

### 5.3.2.2 Buried Directly in Concrete Slab:

When burying an EVERLOC+ polymer joint directly in a concrete slab, it is not necessary to wrap the joint. However, there are some additives in concrete that could potentially damage the fitting material, and in this case, wrapping is recommended. EVERLOC+ LF brass fittings buried directly in a concrete slab must be wrapped.

### 5.3.2.3 Buried in a Sub-base or Underground in Soil:

In these instances, the joint must be wrapped.

### 5.3.2.4 With Foaming Agents:

Foaming agents and solvents in closed-cell foam insulation kits can damage the PPSU fitting material. Therefore, it is necessary to wrap polymer fittings in a protective tape to protect from polyurethane foams.

### 5.3.3 Pressure Testing

The compression-sleeve joint is ready for immediate pressure testing and use after completion of the assembly process. There is no wait time for the system to be put into service. See Section 7.4 for REHAU pressure test procedures.

### 5.3.4 Pressure and Temperature Ratings

The maximum temperature and pressure ratings of the REHAU residential fire sprinkler system are in accordance with NFP 13D, ASTM F877 and CSA B137.5 for SDR9 PEX, as defined in Section 4.4.

### 5.3.5 Ultraviolet Resistance

The fittings and sleeves must never be stored in areas exposed to direct UV light or stored outside of the original cardboard packaging. In addition, the system is not intended for permanent outdoor applications or in areas with continuous UV exposure.

### 5.3.6 Freeze Break Resistance

The flexibility of RAUPEX pipe allows it to expand as water freezes in the pipe as long as the pipe has room to expand. When the water thaws, the pipe returns to its original shape. However, this flexibility does not ensure the integrity of the joint. If the pipe is not allowed to expand (e.g., it is encased in concrete), it may burst.

## NOTICE

Designers and installers must take precautions as per the guidelines defined in NFPA 13D to ensure that pipes do not freeze. Frozen pipes may burst resulting in leaks and operational failures.

### 5.3.7 Chlorine Resistance

EVERLOC+ compression-sleeve joints have a chlorine resistance rating based on the ratings of RAUPEX pipe, as defined in Section 4.7.

### 5.3.8 Stress Corrosion Resistance

EVERLOC+ LF brass fittings have been tested in accordance with UL1821 and NSF/ANSI 14 and comply with the requirement for stress corrosion resistance. However, fittings should not be exposed to harmful chemicals or aggressive water conditions that could result in operational failures.

### 5.3.9 Chemical Compatibility

There are certain chemicals that can damage the EVERLOC+ compression-sleeve system. This applies to external exposure of chemicals and to the transport of such chemicals by the piping system.

Chemicals that may damage the compression-sleeve system include (but are not limited to):

- Adhesives and tapes other than those recommended by REHAU
- Oil/petroleum-based products
- Paints, solvents
- Oxidizing agents (e.g., bleach)
- Disinfectants (e.g., separate dosing unit integrated into building distribution system)
- PVC glues, solvents and cements



Fig. 5.15: DO NOT use harmful chemicals near EVERLOC+ fittings

Many factors, such as exposure time, temperature, pressure and other operating parameters, can influence the performance of a system that is exposed to a chemical. To determine the impact of a particular chemical, short- and long-term pressure testing may be required. In some cases, a system may be resistant to short-term exposure to the chemical, but not resistant to continuous exposure. Each chemical must be evaluated individually. It is the responsibility of the installing contractor to verify chemical compatibility of any chemicals that may come into contact with the polymer material.



### 5.3.10 Copper Soldering

Proper soldering techniques must be followed when soldering all compression-sleeve fittings according to the *Copper Development Association (CDA) Handbook*:

- The surface of the fitting soldering area must be properly cleaned for a good solder connection. Applying flux is not considered sufficient cleaning for the soldering area. Using a proper sanding or brush technique is necessary to remove the surface oxides. In order to prevent further formation of oxides, the flux should be applied immediately after the cleaning process. A proper flux that is compatible with the brass alloy must be used.
- Care must be taken to not overheat the soldering surface as this can lead to the formation of oxides preventing good adhesion of the solder material. It is imperative that the fitting is heated evenly around the entire surface so as to not overheat one particular area.
- All completed solder joints must be tested for joint integrity following the procedures prescribed by prevailing local codes.

When soldering an LF brass EVERLOC+ fitting:

- The fitting must be soldered onto the copper first.
- The solder joint must be allowed to cool to ambient room temperature prior to making an EVERLOC+ connection.
- Never solder after EVERLOC+ connection has been made.

### 5.4 EVERLOC+ Compression-sleeve Tools

Assembling the EVERLOC+ compression-sleeve system requires the use of the EVERLOC+ compression-sleeve tools. Only make EVERLOC+ compression-sleeve joints with these tools.

Before use, read and understand the following safety symbols which are found on the EVERLOC+ compression-sleeve tools.



Safety Alert Symbol – To reduce the risk of injury, follow the specified safety instructions.



Read and follow all safety precautions in the instruction manual. Improper use can lead to serious personal injury or property damage.



To reduce the risk of serious eye injury, always wear proper eye protection.



Risk of electric shock. Never operate the power tool in damp or wet conditions. Never expose to rain or submerge in water or other liquids. Never operate the power tool near wires or cables carrying electric current.



To reduce the risk of severe personal injury, including crush and laceration injury, keep fingers, hands and all parts of your body away from the expander head, hydraulic slide and compression jaws during operation.

### NOTICE

Use only EVERLOC+ compression-sleeve tools for assembly and installation. Use of other tools will result in an improperly assembled joint, which may result in leaks and property damage.

#### 5.4.1 EVERLOC+ Power Tool

For assembly of EVERLOC+ fittings up to 1 in. Use the EVERLOC+ power tool. Refer to *EVERLOC+ Power Tool Product Instruction Manual* (855.725) for a complete understanding of operation, care and use of the tool.



Fig. 5.16: EVERLOC+ power tool

EVERLOC+ power tool standard kit:

- EVERLOC+ power tool
- Expansion adapter
- 1/2, 3/4 and 1 in. EVERLOC+ expander heads (quick change)
- 1/2, 3/4 and 1 in. EVERLOC+ compression jaws
- DEWALT® 12V Li-ion battery (DCB127) (2 batteries per kit)
- DEWALT 12V/20V Li-ion charger 120VAC (DCB107)
- DEWALT 12V/20V Li-ion Battery Charger Instruction Manual
- Pipe cutter
- Lubricant
- Cleaning brush
- Tool case
- EVERLOC+ Power Tool Product Instruction Manual



Fig. 5.17: EVERLOC+ power tool standard kit

### 5.4.2 EVERLOC+ XL Power Tool 1 1/4 to 2 in.

Assembling the EVERLOC+ compression-sleeve system with diameters of 1 1/4 through 2 in. requires the use of the EVERLOC+ XL power tool. Refer to the *EVERLOC+ XL Power Tool Product Instruction Manual* (855.728) for a complete understanding of operation, care and use of the tool.



Fig. 5.18: EVERLOC+ XL power tool

EVERLOC+ XL power tool standard kit:

- EVERLOC+ XL power tool
- Expansion adapter
- 1 1/4, 1 1/2 and 2 in. EVERLOC+ expander heads (quick change)
- 1 1/4, 1 1/2 and 2 in. EVERLOC+ compression jaws
- MAKITA® 18V Li-ion battery (BL1840B) (2 batteries per kit)
- MAKITA 18V Li-ion charger 120VAC (DC18RC)
- *MAKITA 18V Li-ion Battery Charger Instruction Manual*
- Pipe cutter
- Lubricant
- Cleaning brush
- Tool case (black latches)
- *EVERLOC+ XL Power Tool Product Instruction Manual*



Fig. 5.19: EVERLOC+ XL power tool standard kit

### 5.4.3 EVERLOC+ XL Expander Tool 1 1/4 to 2 in.

In addition to the EVERLOC+ XL power tool, the EVERLOC+ XL expander tool can be used for the expansion steps of the 1 1/4 to 2 in. fitting assembly process. Use of this tool in addition to the XL power tool allows for greater efficiency in some installation situations. Refer to the *EVERLOC+ XL Expander Tool Product Instruction Manual* (855.729) for a complete understanding of operation, care and use of the tool.



Fig. 5.20: EVERLOC+ XL expander tool



Fig. 5.21: EVERLOC+ XL expander tool standard kit

EVERLOC+ XL expander tool standard kit:

- EVERLOC+ XL expander tool
- MAKITA 18V Li-ion battery
- *MAKITA 18V Li-ion Battery Charger Instruction Manual*
- Lubricant
- Cleaning brush
- Tool case (gray latches)
- *EVERLOC+ XL Expander Tool Product Instruction Manual*

## 5.5 Fire Sprinklers

An automatic sprinkler is a fire suppression or control device that operates automatically when its heat-actuated element is heated to its thermal rating or above. When activated, water discharges over the specific area on fire.

Only residential sprinklers that have been tested and listed for residential fire protection service may be used. The sprinklers must be installed in accordance with their listing and limitations.

### NOTICE

Nothing in this manual supersedes national or local code requirements or the recommendations of other manufacturers regarding their components. Observe all applicable national, state and local laws, regulations, standards, codes and ordinances. If you believe REHAU product information conflicts with applicable code requirements, industry standards, or the recommendations of other manufacturers regarding their components, contact the REHAU distributor in your area and consult with the building authority having jurisdiction before installation.

There are four types of recommended sprinklers: flat plate concealed pendent, domed concealed pendent, recessed pendent and horizontal sidewall.

#### 5.5.1 Flat Plate Concealed Pendent Sprinklers

Flat plate concealed pendent sprinklers have a cover plate that is installed flush to the ceiling. During fire conditions, when the temperature around the sprinkler approaches its operating temperature, the cover plate detaches and falls away.

Continued heating of the now exposed sprinkler causes the sprinkler's heat responsive element to disengage, releasing the sealing assembly, allowing water to flow.



Fig. 5.22: Flat plate concealed pendent sprinkler

### ⚠ WARNING

Do not paint the cover plate of the concealed sprinkler. Paint may interfere with the operation of the sprinkler, preventing it from achieving its life safety function.

#### 5.5.2 Domed Concealed Pendent Sprinklers

Domed concealed pendent sprinklers have a cover plate assembly that, when installed, protrudes below the ceiling. During fire conditions, when the temperature around the sprinkler approaches its operating temperature, the cover plate detaches and falls away.

Continued heating of the now exposed sprinkler causes the sprinkler's heat responsive element to disengage releasing the sealing assembly. This allows water to flow from the sprinkler.



Fig 5.23: Domed concealed pendent sprinkler

### ⚠ WARNING

Do not paint the cover plate of the concealed sprinkler. Paint may interfere with the operation of the sprinkler, preventing it from achieving its life safety function.

#### 5.5.3 Recessed Pendent Sprinklers

Recessed pendent sprinklers are visible in the ceiling and do not have a cover plate. During fire conditions, continued heating of the exposed sprinkler causes the heat responsive element to disengage. This allows water to flow from the sprinkler.



Fig 5.24: Recessed pendent sprinkler

#### 5.5.4 Horizontal Sidewall Sprinklers

Horizontal sidewall sprinklers are visible in the wall and do not have a cover plate. During fire conditions, continued heating of the exposed sprinkler causes the heat responsive element to disengage. This allows water to flow from the sprinkler.



*Fig 5.25: Horizontal sidewall sprinkler*



# 6. SYSTEM PLANNING

The overall system layout and calculation of the hydraulic demand must conform to all requirements of NFPA 13D and IRC P2904. Prior to installation, construction plans showing sprinkler locations, piping layout and hydraulic demand (flow in GPM and required pressure in psi) must be submitted to and approved by the authority having jurisdiction. Any deviation from the approved plans requires permission from local authorities.

The critical points in design of an NFPA 13D and IRC P2904 sprinkler system are:

- Identify local jurisdiction requirements, including determination of pertinent building, fire protection and plumbing codes.
- Obtain residence characteristics.
- Identify the water supply source and available flow in GPM and supply pressure in psi.
- Identify the water supply service line including elevation difference between connections and routing of the service line into the residence.
- Determine the specifications for the sprinklers including water flow and operating pressure requirements and coverage area specifications.
- Lay out the piping system in the residence as a looped, gridded or straight-run system as defined by NFPA 13D.
- Lay out the piping system for cold and hot water distribution.
- Perform the hydraulic calculations on the system to determine system performance.
- Coordinate fire sprinkler installation with other building trades to minimize installation/scheduling conflicts. Verify installation of sprinkler system per plan (includes sprinkler locations and proper mounting height).
- Ensure compliance with prevailing local plumbing codes if the fire sprinkler system connects to plumbing fixtures.

The following is an overview for planning and designing a PEXa plumbing/residential fire sprinkler system.

## 6.1 Step One - Determine Local Jurisdiction Requirements

Prior to initiating a system design, determine the local jurisdictional requirements. This includes identifying the pertinent sprinkler installation standards and plumbing codes followed by the authority having jurisdiction. In addition, the local licensing requirements for the qualified sprinkler system installer must also be determined.

Fire sprinkler plans for residential systems are reviewed by the local authority having jurisdiction, so the design/installation of the system must be performed by a qualified sprinkler designer/installer familiar with local requirements.

## 6.2 Step Two - Obtain Residence Information

The next step is to identify the characteristics of the residence to ensure the residence can be protected with a NFPA 13D residential sprinkler system. Some local building codes may contain requirements such as fire separation walls that will allow buildings that contain more than two dwelling units to be protected with a residential sprinkler system. This information must be confirmed with the local authority having jurisdiction.

Next, the characteristics of the residence must be identified. This includes the layout of the home, individual room sizes, heights of all flat ceilings and pitch of all sloped ceilings. In addition, all areas of each story should be identified including crawl spaces, basements, garages, attics and individual levels.

## 6.3 Step Three - Identify Water Supply Source, Flow and Pressure

Identify the water supply source, available flow in GPM and supply pressure in psi.

As defined by the NFPA 13D standard, every piping system shall have at least one automatic water supply. Sources that qualify as automatic water supply are defined in NFPA 13D, Chapter 6.

Once the water supply source has been identified, the available flow and supply pressure must be determined. This information can be obtained from the local waterworks authority or can be measured at the nearest hydrant. When determining the system supply pressure, be sure to consider minimum pressure conditions occurring during heavy usage periods (e.g., evenings, summer months). An accurate assessment of the available flow and supply pressure is crucial for proper design and layout of the sprinkler system.

Hydraulic calculations are required to determine the exact requirements for each system.

#### 6.4 Step Four - Determine Layout of Water Supply

Determine the layout of the water supply, the underground piping that will supply water to the residence. This includes determining the length, type and size of pipe required and accounting for pressure loss.

Pipe needs to be sized to minimize pressure loss through the service line during maximum flow demand of the system. Determine the elevation difference between the connection to the water supply source and the grade of the residence.

Following are other considerations for calculating the pressure loss through the service line.

##### 6.4.1 Shut-off Valves

For system maintenance and safety, every system must have a control valve to shutoff the water flow. Valves must be installed and operated according to NFPA 13D and prevailing local codes.

A sign shall be affixed adjacent to the main shut-off valve that states the following:



Fig. 6.1: Warning sign for main water shut-off

##### 6.4.2 Water Meters

Pressure loss through the water meter must be taken into consideration during design and installation. Some water meters have associated flow limits that when exceeded may result in improper system operation.

The designer/installer should verify that the installed water meter's pressure loss is within the specifications that were used for the design of the system and that the maximum flow rate, as recommended by the water meter manufacturer, is not exceeded.

##### 6.4.3 Pressure Reducing Valves

As required by typical plumbing codes, if the pressure entering the residence is above 80 psi (6 bar), a pressure reducing valve (PRV) is required to limit the pressure to a maximum of 80 psi (6 bar). When using a PRV, the designer must take into consideration the pressure loss through the PRV. Some PRVs have associated flow limits that when exceeded may result in improper system operation.

If a PRV is used on a stand-alone sprinkler system, an automatic means of pressure relief should also be installed on the sprinkler side.

##### 6.4.4 Backflow Requirements

The designer/installer must confirm with the authority having jurisdiction on backflow requirements.

##### 6.4.5 Additional Flow-restricting Devices

Design and calculation of the system should account for any flow restricting devices that may be added to the system in the future such as water softeners, filtration systems and automatic shut-off valves.

##### 6.4.6 Smoke Detectors and Water Flow Alarms

The NFPA 13D standard does not require a water flow alarm on a piping system when the dwelling has smoke detectors throughout the dwelling unit. The smoke detectors must be installed in accordance with NFPA 72 *National Fire Alarm Code*.

#### 6.5 Step Five - Determine Sprinkler Requirements

Performance requirements for sprinklers define the water flow, operating pressure and coverage area specifications. The coverage area dictates the flow rate and pressure of the system. Typical coverage area specifications for sprinklers range from 12 x 12 ft to 20 x 20 ft (3.7 x 3.7 m to 6 x 6 m).

The local code and the listing of the sprinkler manufacturer define proper spacing of the sprinklers. The minimum distance between residential sprinklers to prevent cold soldering, which is the spray from one operating sprinkler onto an adjacent sprinkler preventing its proper activation, is typically 8 ft (2.4 m). The maximum sprinkler spacing should be no farther than the listed coverage area.

To ensure proper coverage in each room, lay out the sprinklers, taking into consideration all flat and sloped ceilings, as well as proper locations for sidewall heads. When locating the sprinklers, ensure proper clearance from ceiling fans, lights, duct work, registers and fireplaces.

## 6.6 Step Six - Design Piping System Layout

Lay out the piping system for the sprinklers using either a gridded, looped or straight-run configuration as defined by NFPA 13D.

### 6.6.1 Connections to Domestic Cold Water Plumbing Systems

EVERLOC+ fittings can be installed in the main sprinkler piping lines to allow for connection to the plumbing fixtures. Connections to the system that are only supplying plumbing fixtures are required by NFPA 13D to meet local plumbing codes. RAUPEX UV shield pipe and EVERLOC+ fittings meet all requirements for domestic plumbing applications.



Fig. 6.2: Domestic cold water plumbing connection

## 6.7 Step Seven - Perform Hydraulic Calculations to Verify System Performance

Hydraulic calculations must be performed to verify that the system is sized properly to achieve the flow and pressure required for proper sprinkler operation. Calculations must be performed using an approved fire sprinkler design method in accordance with local requirements.

Hydraulic calculations are typically done by starting with the flow and pressure demand for the most hydraulically demanding point in the system for both one-head activation and two-head activation. The most hydraulically demanding point in the system is usually the sprinkler most distant from the water supply.

The calculations must show that the pressure and flow available at the street is adequate to provide the required flow and pressure to the sprinklers with one- and two-head flow scenarios.

If the calculations do not show that adequate flow and pressure is available, modifications to the piping system can be made in an attempt to meet the requirements of the system. These modifications include:

- Reducing the coverage area of the sprinklers thus possibly reducing the required flow or pressure at each head
- Increasing the size of the service main
- Adding a piping loop to the system
- Upsizing the piping in the system from 3/4 to 1 in.

If the calculations still do not show adequate flow and pressure is available for proper system operation, consideration for a pressure booster system with optional storage capacity may be necessary.

## 6.8 Step Eight - Obtain AHJ Approval

Once the complete system is designed and properly calculated, final approval from the local authority having jurisdiction must be obtained prior to installation.

# 7. INSTALLATION CONSIDERATIONS

The following sequence is recommended to install the FIREPEX fire sprinkler system:

- Determine fire sprinkler location
- Install sprinkler fittings
- Route and connect pipe
- Install plumbing fittings
- Install plumbing pipe
- Install fire sprinklers
- Perform pressure test
- Perform flow test

## 7.1. Ensuring Design Meets Installation Guidelines

RAUPEX white UV shield pipe in 3/4 to 2 in. sizes is listed to supply the FIREPEX system.

RAUPEX pipe in all sizes is listed for plumbing applications and can be connected to the sprinkler system as allowed by the local code.

The following are guidelines for using RAUPEX white UV shield pipe and EVERLOC+ compression-sleeve fittings in fire sprinkler systems:

- Protection must be provided for RAUPEX pipe and EVERLOC+ fittings. The minimum protection must consist of either:
  - One layer of 3/8 in. (9.5 mm) gypsum wallboard,
  - A suspended membrane ceiling with lay-in panels or tiles having a weight of not less than 0.35 lbs per sq ft (1.7 kg per sq m) when installed with metallic support grids,
  - 1/2 in. (13 mm) plywood soffits,
  - One layer of 1/2 in. (13 mm) plywood, or
  - Other material having a 15 minute fire rating.
- During remodeling or ceiling repair, use appropriate precautions to properly protect the pipe.
- Do not use RAUPEX pipe or EVERLOC+ fittings for sprinkler systems in combustible concealed spaces where sprinklers are required.
- RAUPEX pipe and EVERLOC+ fittings are intended for use in areas where the maximum ambient temperature does not exceed 120°F (49°C). If the ambient temperature is expected to exceed this limitation, the system must be properly protected.
- Piping must be installed at least 24 in. (61 cm) from air return grilles or other openings in the ceiling.

## 7.2 Mounting FIREPEX Sprinkler Fittings

Determine location of sprinklers based on design. Be sure to verify that there are no obstructions or deviations from design. If modifications are necessary, consult with the designer to ensure proper coverage of sprinklered area.

The FIREPEX sprinkler fittings are available in 3/4 and 1 in. sizes. Each fitting has a 1/2 in. NPT female adapter for mounting of the fire sprinkler with integrated mounting holes for both horizontal and vertical installation. Fittings should be mounted using #10 x 1 1/2 in. wood screws.

FIREPEX sprinkler fittings are specially designed to affix the fire sprinkler in place so that during activation, the reaction forces caused by the flow of water through the sprinkler will not displace the sprinkler. FIREPEX sprinkler fittings may be mounted to a wood blocking structure.



Fig. 7.1: Mounting FIREPEX sprinkler fitting

### 7.2.1 Determining Mounting Height

The following guidelines may be used to correctly position the FIREPEX sprinkler fittings. These guidelines apply to both the FIREPEX tee and elbow fittings. When installing, blocking may be necessary in order to position the fitting and sprinkler correctly.

#### **⚠ WARNING**

Mounting height of sprinkler must be within sprinkler manufacturer guidelines. Failure to properly position the sprinkler can cause disruption in discharge or delay in sprinkler activation, resulting in property damage and possible loss of life.



### 7.2.1.1 Flat Plate Pendant Concealed Sprinkler Mounting

For a flat-plate pendent concealed sprinkler, the bottom of the FIREPEX sprinkler fitting bracket can be located using:

$$H = S - DW + 0.35 \text{ (inches)} \quad (1)$$

where:

- H is the distance between the bottom of the joist and the bottom of the FIREPEX sprinkler fitting bracket
- S is the distance from the top of the threads of the fire sprinkler to the face of the drywall (provided by the sprinkler manufacturer)
- DW is the thickness of the drywall.

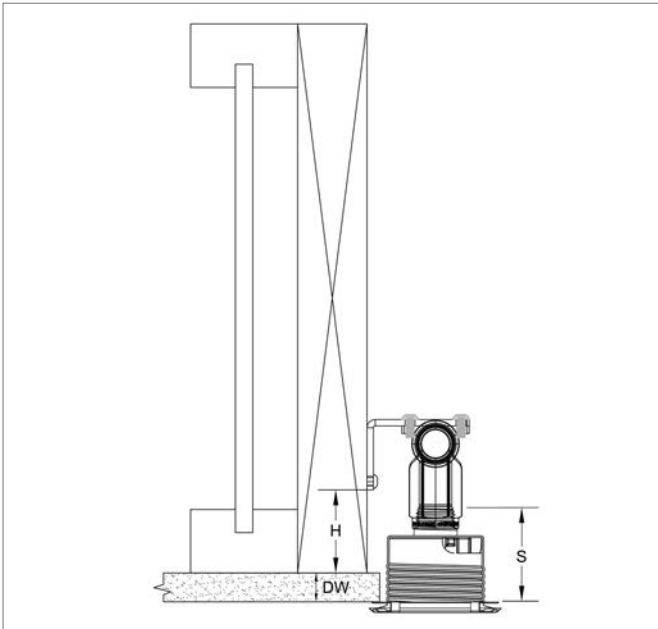

Fig. 7.2: Flat plate pendent concealed sprinkler mounting diagram



Fig. 7.3: Flat plate pendent concealed sprinkler mounting example

### 7.2.1.2 Domed Concealed Pendent Sprinkler Mounting

For a domed concealed pendent sprinkler, the bottom of the FIREPEX sprinkler fitting bracket can be located using:

$$H = S - DW - D + 0.35 \text{ (inches)} \quad (2)$$

where:

- H is the distance between the bottom of the joist and the bottom of the FIREPEX sprinkler fitting bracket
- S is the distance from the top of the threads of the fire sprinkler to the face of the deflector (provided by the sprinkler manufacturer)
- DW is the thickness of the drywall
- D is the distance between the face of the drywall and the face of the deflector (provided by sprinkler manufacturer).

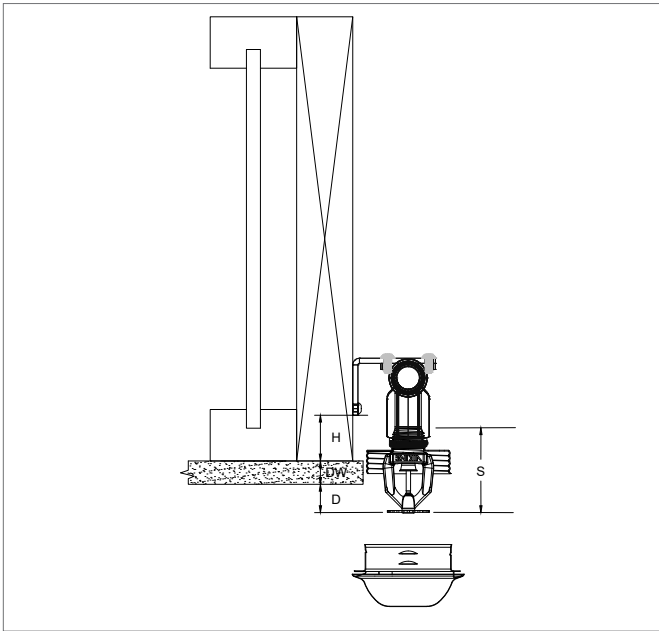

Fig. 7.4: Domed concealed pendent sprinkler mounting diagram



Fig. 7.5: Domed concealed pendent sprinkler mounting example

### 7.2.1.3 Recessed Pendant Sprinkler Mounting

For a recessed pendant sprinkler, the bottom of the FIREPEX sprinkler fitting bracket can be located using equation 2.

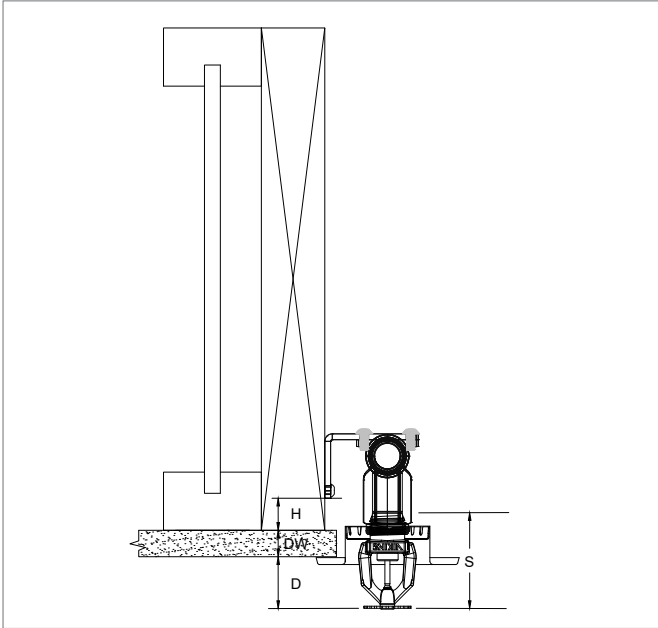

Fig. 7.6: Recessed pendant sprinkler mounting diagram



Fig. 7.7: Recessed pendant sprinkler mounting example

### 7.2.1.4 Horizontal Sidewall Sprinkler Mounting

Positioning the FIREPEX sprinkler fitting for a horizontal sidewall sprinkler can be done using equation 2, where H gives distance from the face of the stud to the bottom of the FIREPEX sprinkler fitting bracket.

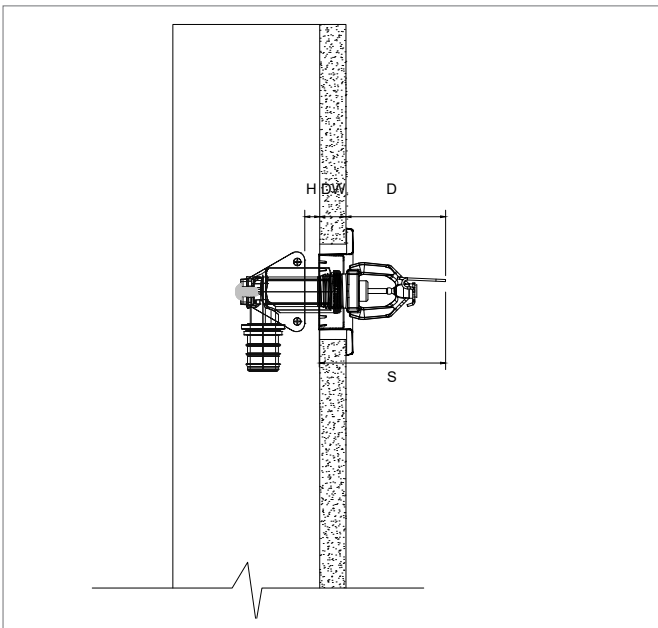

Fig. 7.8: Horizontal sidewall sprinkler mounting diagram



Fig. 7.9: Horizontal sidewall sprinkler mounting example

### 7.2.2 Connecting RAUPEX pipe

Before beginning installation, refer to *Section 5.2 Fitting Assembly*.



Fig. 7.10: Expanding RAUPEX white UV shield pipe



Fig. 7.11: Compressing EVERLOC+ sleeve

### 7.3 RAUPEX Pipe Packaging

RAUPEX pipe coils are shipped in cardboard boxes to protect them from UV radiation, rain, dirt and other hazards. Straight lengths of RAUPEX pipe are packaged and shipped in black polyethylene bags.

Keep pipe in the original packaging until it is required for installation. Return unused pipe to the packaging.

Avoid the following:

- Dragging pipe over rough objects
- Contact of pipe with petroleum products such as oil, gasoline, paint thinner
- Exposure of pipe to soldering or any open flame
- Excessive or permanent exposure to UV radiation

### 7.4 EVERLOC+ Fittings Packaging

EVERLOC+ fittings and sleeves are shipped in cardboard boxes to protect them from UV radiation, rain, dirt and other hazards. Keep the products in the original packaging until they are required for installation. Return unused products to the packaging for storage.

Fittings and sleeves must be handled with care. At a minimum, avoid the following:

- Storing loose fittings in tool boxes
- Contact with oil or oily products such as gasoline, paint thinner, glues or solvents
- Exposure of polymer fittings and PEXa sleeves to soldering or any open flame
- Excessive or permanent exposure of polymer fittings and PEXa sleeves to UV radiation

### 7.5 Uncoiling Pipe

For best results when installing RAUPEX pipe from a coil, use a REHAU approved uncoiling device. This will allow the pipe to lay flat (not twisted) when installed. Twisting the pipe may place stress on the pipe after installation.

RAUPEX may be taken from a coil without the use of an uncoiling device. When using this method, be sure to roll the pipe from the coil. Do not lay the coil flat on its side and pull the pipe up over the side of the coil as this will twist the pipe.

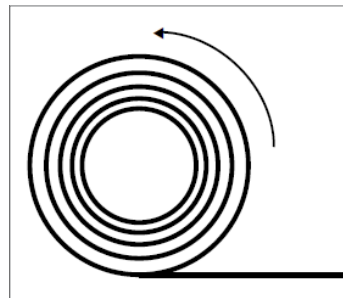

Fig. 7.12: Uncoiling RAUPEX pipe

### 7.6 Bending Pipe

RAUPEX pipe may be bent, with and without the use of a pipe bend support. The minimum bend radius for RAUPEX in a standard installation is five times the OD of the pipe.

RAUPEX may also be heated to achieve a minimum bend radius of three times the OD of the pipe. A heat gun may be used to heat the pipe. Heat RAUPEX and bend slowly. Once the RAUPEX is bent, remove the heat source and secure the RAUPEX. Avoid overheating RAUPEX (brown discoloration) and do not apply direct flame to RAUPEX to heat it (from a soldering torch, for example).



**Table 7.1: RAUPEX Bend Radius**

Typical Minimum Bend Radius in (mm)			
Pipe Size	Typical 8X OD	Min. Cold 5X OD	Min. Heated 3X OD
3/4 in	7.0 (178)	4.375 (111)	2.625 (67)
1 in	9.0 (229)	5.625 (143)	3.375 (86)
1 1/4 in	11.0 (279)	6.875 (175)	4.125 (105)
1 1/2 in	13.0 (330)	--	--
2 in	17.0 (432)	--	--

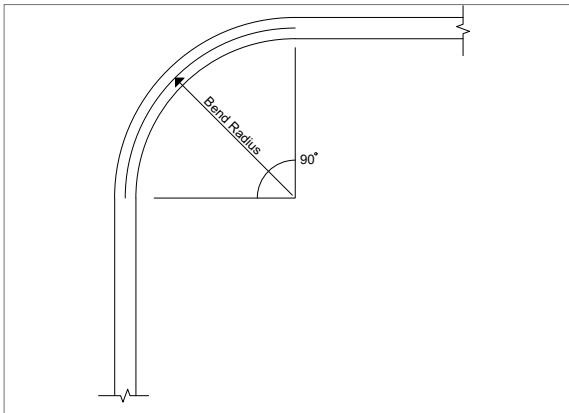

Fig. 7.13: Bend radius of RAUPEX pipe

**7.7 Distance Between Fittings**

A minimum distance between EVERLOC+ fittings is required to ensure the fittings are not damaged during the expansion process by the installation tools. A minimum pipe length of 3 times the length of sleeve is required between fittings for proper installation.

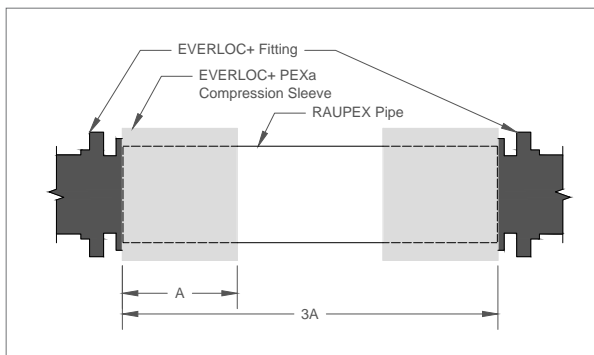

Fig. 7.14: Required minimum distance between fittings

**7.8 Pipe Protection**

Place pipe protection around RAUPEX pipe to prevent abrasion when passing through the building's framework.

When RAUPEX pipe passes through studs, walls, floor plates, joists and other structural members, care must be taken not to damage the pipe.

Protection is not required for installation in wood studs, walls, floor plates or joists if the following provisions are met:

- The hole is at least 1/4 in (6 mm) larger than the outside diameter (OD) of the pipe
- The pipe is free to move during expansion and contraction
- The hole is clean (e.g., free of splinters, burrs and rough edges)
- The hole is supporting only the weight of the pipe (with fluid), and not a mechanical device
- The hole has smooth, non-abrasive interior surface (e.g., bushing)
- Prevailing local codes allow such practice

Use of PE protection sleeve or other approved support device is required for RAUPEX pipe when passing through holes in steel, concrete or masonry walls, joists and other structural members.

When RAUPEX pipe runs through any abrasive material, or a hole that does not allow free movement, it must be protected by PE protection sleeve or another approved installation accessory, such as suspension clamps or isolators.



Fig. 7.15: Isolation suspension clamps



Fig. 7.16: Pipe isolator



Fig. 7.17: PE protection sleeve



### 7.9 Supporting RAUPEX Pipe

RAUPEX pipe should be installed so that it is aligned and stable.

- Standard Copper Tube Size (CTS) hangers, including clevis and loop hangers, can be used to support suspended sections of pipe.
- Suspended sections of pipe shall be installed so that there is no sag in the pipe system.
- All materials in contact with the pipe shall be approved for use with RAUPEX pipe.
- Ensure supports will not cut, scratch or damage the pipe.
- Suspended installations in wood-frame construction can utilize strut channel hanging with all-thread as the support device with the appropriate clamps to secure pipe to the strut. When clamping pipe, be sure not to deform the pipe with the force of the clamp.
- Installations in steel-frame construction can be done similarly, but can also use beam clamps to secure the all-thread to steel I-Beams.
- Steel joist space can be used as the support method.

When not installing in suspension, other support mechanisms for RAUPEX pipe can be used. These include single nail hooks, pipe support bends, talon drive hooks and locking clips. These can also be used for smaller branch runs of pipe as well as to assist in making bends to connect to fixtures.

RAUPEX pipe up to 1 in. diameter must be supported with a maximum spacing of 32 in (80 cm) horizontally and 10 ft (3 m) vertically. RAUPEX pipe larger than 1 in. diameter must be supported with a maximum spacing of 48 in (120 cm) horizontally and 10 ft (3 m) vertically. Always comply with the prevailing local code for support spacing intervals.



Fig. 7.18: Single nail hooks



Fig. 7.19: Pipe support bend



Fig. 7.20: Talon drive hooks



Fig 7.21: Locking clip

### 7.10 Supporting EVERLOC+ Fittings

Supports and clamps shall not be placed directly on the EVERLOC+ fitting, multi-port tee or compression sleeve. Always comply with prevailing local codes.

### 7.11 Copper Soldering

Proper soldering techniques must be followed when soldering all compression-sleeve fittings according to the Copper Development Association (CDA) Handbook:

- The surface of the fitting soldering area must be properly cleaned for a good solder connection. Applying flux is not considered sufficient cleaning for the soldering area. Using a proper sanding or brush technique is necessary to remove the surface oxides. In order to prevent further formation of oxides, the flux should be applied immediately after the cleaning process. A proper flux that is compatible with the brass alloy must be used.
- Care must be taken to not overheat the soldering surface as this can lead to the formation of oxides preventing good adhesion of the solder material. It is imperative that the fitting is heated evenly around the entire surface so as to not overheat one particular area.
- All completed solder joints must be tested for joint integrity following the procedures prescribed by prevailing local codes.



Fig. 7.22: Solder prior to making EVERLOC+ connection



Fig. 7.23: Never solder after EVERLOC+ connection has been made

### ⚠ WARNING

- Use gloves and a holding tool. Heated pipe and fittings can cause burns.
- Never use a torch, open flame or heat gun on a pressurized system. Exceeding the temperature pressure ratings will result in dangerous separation of materials leading to serious injury or death.
- Never rework a connection that is under pressure. Depressurize the system, cut out connection and replace.

### 7.12 Kink Repair

RAUPEX pipe is flexible and resists kinking even at temperatures well below freezing. If the pipe does become kinked, flow may be obstructed or reduced. Kinked pipe must be repaired.

Straighten the pipe by heating the area with a heat gun, rotating the heat gun around the pipe to evenly heat the surface. Always use caution when operating a heat gun and never use a torch or open flame to heat the pipe.

When fully heated, the pipe will become transparent. When the kink is gone, turn off the heat gun and let the area cool. (It is normal for small bubbles or wrinkles to appear.) This type of heating will anneal or stiffen the pipe, making it stronger but also less flexible in the heated area. Therefore, do not try to bend the pipe in the same spot. This may require a slight adjustment of fasteners.

#### **WARNING**

- Never use a torch, open flame or heat gun on a pressurized system. Exceeding the temperature pressure ratings will result in dangerous separation of materials leading to serious injury or death.

### 7.13 Installing Sprinklers

The sprinklers must be installed in accordance with their listing and limitations. Follow all sprinkler manufacturers' guidelines for threading sprinkler into FIREPEX fire sprinkler fittings.

Sprinkler wrenches are installation tools specifically designed for use with residential sprinklers. The appropriate wrench must be used with the individual sprinkler to provide the proper leverage when tightening and to minimize slippage during installation.

#### **NOTICE**

Using wrenches other than those designated by the fire sprinkler manufacturer may damage the fire sprinkler.

### 7.14 Pressure Testing

REHAU only provides the general guidelines for performing a pressure test on a REHAU PEXa piping system as set forth below.

#### **WARNING**

- Failure to follow proper safety precautions for an air pressure test could result in dangerous separation of the material, leading to serious injury or death.
- Use personal protective equipment. To reduce the risk of eye injury, always wear close-fitting protective eye wear with side protection. Eye wear must be impact-rated and marked as complying with ANSI Z87.1.
- Never use a torch, open flame or heat gun on a pressurized system. Exceeding the temperature pressure ratings will result in dangerous separation of materials leading to serious injury or death.
- Never rework a connection that is under pressure. Depressurize the system, cut out connection and replace.
- To reduce the risk of personal injury, only qualified persons conducting and/or inspecting the pressure test should be present.

The following guidelines apply to both compressed air and hydrostatic (water) testing:

#### 7.14.1 General Recommendations

- A pressure test must always be performed prior to closing in the system (e.g., behind drywall).
- Perform test using water or air at ambient temperature. Do not exceed 150 psi (1030 kPa) for the piping system. Verify maximum pressure limits are not exceeded for all system components prior to performing the pressure test.
  - When air pressure testing with EVERLOC+ polymer fittings do not exceed 120 psi (825 kPa).
- For RFH and SIM systems, a pressure test must always be performed on the system prior to and during the installation of the thermal mass to ensure that RAUPEX pipe and connections are leak free. For dry systems (e.g., joist space), a pressure test must be performed after installation and up to the time that the system is put in operation.
- Tests shall comply with local codes where applicable and, where required, shall be witnessed by the building official.

#### 7.14.2 Pressure Testing with Air

Air can store a high amount of energy as compared to water during a pressure test. Due to this higher energy, different failure modes of system materials must be understood by persons conducting the pressure test.

- If a thermoset polymer (e.g., PEXa pipe) is over-pressurized and fails (bursts), it does so in a ductile mode, meaning that the pipe will swell and then split with no separation of fragments.
- If a rigid thermoplastic polymer material (e.g., PPSU) is over-pressurized and fails (bursts), it does so in a brittle mode and can result in separation of the material.

### 7.14.3 REHAU Pressure Test Procedure

- Use an air test if conditions do not permit a water test (e.g., freezing conditions, insufficient water supply/pressure).
- Air temperature will affect the gauge pressure. Perform all pressure tests at a constant temperature. Verify maximum pressure requirements for other systems prior to performing the test.
- Conduct a visual inspection of the piping system, to ensure all connections have been properly made and all piping has been properly secured prior to pressurization.
- Perform a preliminary pressure test pressurizing the system to 1.5 times the maximum operating pressure not to exceed the maximum pressures defined above for 30 minutes.
- As the piping expands, restore pressure, first at 10 minutes into the test and again at 20 minutes.
- At the end of the 30-minute preliminary test, pressure must not fall by more than 5 psi from the maximum, and there shall be no leakage.
- After performing the preliminary test, perform the main pressure test immediately. The main pressure test shall last at least 2 hours. The test pressure should be restored and must not fall more than 3 psi after 2 hours. No leakage should be detected.
- It is recommended to maintain pressure on the system during further construction, where practical, to immediately identify any damage. If a water (hydrostatic) test is used, protect the water from freezing or drain water from pipes.
- If any repairs or corrections are necessary, depressurize the system before proceeding.

### **NOTICE**

- When other thermoplastic piping materials (e.g., CPVC, PP-R) are present in the piping system, these sections of piping must be isolated from the REHAU PEXa piping system during the pressure test. The installer must consult the other component manufacturer's installation instructions for pressure testing those sections of the system.
- Always refer to the local codes for pressure testing requirements and use air testing only if approved by the local Authority Having Jurisdiction (AHJ).
- REHAU only provides the general guidelines for performing a pressure test, which by no means supersede or are intended to contradict safety requirements. It is the responsibility of the installing contractor to ensure a proper and safe pressure test is performed on site.
- All other trades must be notified that the pressure test will be conducted on the piping system.

### 7.15 Testing System Flow

The local Authority Having Jurisdiction (AHJ) may require a flow verification test of the two most hydraulically remote sprinklers. This flow verification test is a valuable procedure to ensure the installed fire sprinkler system is operating as designed. The local inspector must be notified prior to performing the flow test to ensure the inspector is present during the test.

The flow test must be performed after all piping, fittings, sprinklers and plumbing connections have been completed and successful pressure testing of the system has been done. The flow test must occur prior to closing in the system.

The flow verification test consists of the following steps:

1. Remove the sprinklers.  
Make sure the piping system is not under pressure and water has been drained from the portion of piping serving the sprinklers. Using the manufacturers' sprinkler wrench, carefully remove the sprinklers intended for testing and secure in a safe place in order to avoid any damage.
2. Install the appropriate test fittings.  
Obtain proper test fittings that consist of a 1/2 in. MPT adapter that will connect to the FIREPEX sprinkler fitting, a flow control valve, a pressure gauge, a sprinkler test orifice and a 30-gallon bucket. Thread male adapter into the sprinkler fittings. Use pipe thread seal tape to make the threaded connections watertight.
3. Open the main shut-off valve.  
Ensure all connections are made and all plumbing connections are sealed. Open main shut-off valve to supply water to the system.
4. Open the ball valve on the test fittings.  
Open the valves and bleed all air from the system using the containment buckets. Once all air is purged from the system, close the valves. The system should be pressurized to its working pressure.
5. Record the static pressure readings.  
Note the static pressure at the manifold pressure gauge and at the pressure gauge on the test apparatus.
6. Perform the flow verification test.  
Simultaneously open the ball valves on the test apparatuses. Ensure the buckets are properly placed under the apparatuses to capture all water. The ball valves are to be open for exactly 60 seconds. During this time, record the residual pressure readings. After 60 seconds, shut the ball valves immediately.

7. Determine the number of gallons in the buckets.  
Determine the number of gallons of water in the buckets after 60 seconds of water flow. This value represents the amount of flow in the system in gallons per minute (GPM).
8. Compare the results.  
Compare the results of the flow test to the system design values. Both the residual pressure and flow (GPM) must be equal to or greater than the design values to ensure a properly working system.

***NOTICE:***

Do not commission a system that does not meet the fire protection flow and pressure requirements.

9. Reinstall the sprinklers.  
Using the appropriate sprinkler wrench, thread the sprinklers into the fitting. New thread seal tape shall be applied to the sprinklers prior to installation.

**7.16 Maintaining the System**

The installer needs to communicate that the owner or property manager is responsible for the condition of the fire sprinkler system and must keep the system in normal operating condition. At a minimum, a recommended monthly maintenance schedule should include the following:

- Visual inspection of all sprinklers to ensure against obstruction or spray.
- Inspection to ensure sprinklers are not damaged, broken, painted or obstructed.
- Inspection of the system pressure gauge to ensure the system is pressurized.
- Inspection of all valves to ensure that they are open.
- Flow verification of the water supply.
- Inspection of booster pumps, if applicable.

For updates to this publication, visit [na.rehau.com/resourcecenter](http://na.rehau.com/resourcecenter)

The information contained herein is believed to be reliable, but no representations, guarantees or warranties of any kind are made as to its accuracy, suitability for particular applications or the results to be obtained therefrom. Before using, the user will determine suitability of the information for user's intended use and shall assume all risk and liability in connection therewith. © 2020 REHAU

855.658 US.CA/en. 05.2020