



Thermostatic Mixing Valve Series 30 MR Installation and Maintenance Instructions

VERY IMPORTANT!

To the Installer:
 These installation and maintenance instructions must be reviewed by all installers and by the owners of the building or property where the device will be installed.

Applications

The Series 30 is a multi-purpose thermostatic mixing valve designed for ease of installation and a wide variety of uses. The TMV offers accurate temperature control via a self-regulating thermostat. The valves are designed to control temperature of Domestic Hot Water (DHW), Hydronic Radiant Space Heating, Heat Pump, and Solar Systems for central mixing applications.

Series 30 MR offer the following features:

- Anti-scald function* (see below).
- Listed to meet ASSE 1017 requirements (applies to 85–120°F and 95–140°F only).
- Purpose: Mixing function.
- Temperature Ranges: 70–110°F (20–43°C), 85–120°F (29–49°C), or 95–140°F (35–60°C).
- Maximum working pressure: 150psi (10 bar).
- Maximum hot water inlet temperature: 194°F (90°C).
- Maximum pressure difference between hot and cold supply: 20% to max. 44psi (3 bar).
- Minimum flow requirement: 0.5USgpm (113.5l/hr).
- Designed for long-life and easy maintenance.
- Minimal outlet temperature fluctuation.

* The Series 30 is designed to respond to a failure of the cold water supply by a complete closing of the hot water supply port before the outlet temperature exceeds the setting by 18°F (10°C).

NOTE: To ensure that the anti-scald function works properly, the pressure difference between inlets and outlet should not exceed 72 psi (5 bar), otherwise minor leakage could occur.

Setting

The Series 30 MR temperature setting is accomplished by adjusting the setting wheel between 1 and 6 to obtain the required mixed water temperature. For quick setting refer to the table below. Series 30 MR valves are not factory calibrated. For accurate setting, measure the mixed water temperature once hot and cold supply temperatures are stabilized. Adjust setting as required to obtain the desired temperature.

Installation

To protect the TMV from excessive heat, and avoid voiding the warranty, the tailpieces must be soldered before attaching them to the TMV (see below). Gaskets supplied must be installed as shown.

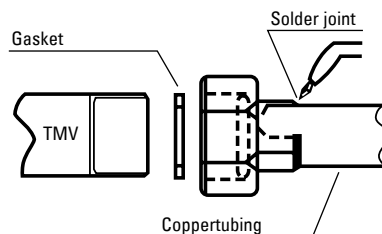

1. Position union nut over tailpiece before soldering.
2. Solder tailpiece to tubing.
3. Insert gasket in nut.
4. Connect to TMV.

NOTE: When installing a TMV on plumbing systems using CPVC piping, always follow the pipe manufacturer's instructions.

Hot water Temperature	70–110°F						85–120°F						95–140°F						85–160°F					
	1	2	3	4	5	6	1	2	3	4	5	6	1	2	3	4	5	6	1	2	3	4	5	6
120°F	67	74	81	87	94	109	80	90	97	102	107	115	95	106	115	119	120	120	86	100	112	118	120	120
140°F	68	75	82	90	97	113	81	91	99	104	109	117	97	108	117	126	133	140	87	100	114	127	136	140
160°F	69	76	84	92	100	118	82	93	100	106	112	118	99	109	118	127	135	145	88	101	117	129	144	152
180°F	70	77	86	95	102	122	82	95	102	108	114	120	100	111	120	129	135	149	89	102	119	134	148	160

Note: Table is based on 50°F cold water and no difference between hot and cold water supply pressures. For other cold water temperatures correct the mixed temperature by 1°F for every 10°F from 50°F, up or down.

Push pin to remove cap.



Remove cap.



Adjust temperature setting between 1–6.



Replace cap.



Mount label on cap to seal valve. Space is provided on the label to indicate measured outlet temperature, date and signature of installer.



Over time the temperature setting may have to be adjusted due to scaling or dirt deposited in the valve.

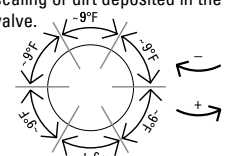

Installation continued

The Series 30 MR valves are not intended to provide final temperature control at the fixtures or point of use. Use Series 30 HR/HV valves that meet ASSE 1016 for these applications.

The valve should be installed below the storage tank or water heater as shown in Fig. 3 wherever possible. If the valve is installed adjacent to, or higher than the storage tank or water heater, it is important to prevent gravity circulation during times where there is no consumption of water. This is done by various methods such as a heat trap loop or a check valve in the cold water feed line as shown

in the examples below.

A check valve should also be installed whenever a high temperature (uncontrolled) water outlet is included (Fig. 4). For installation of a TMV in a system providing recirculated tempered water using a circulation pump refer to Fig. 6. An aquastat to limit circulation of recirculated water is not required with Series 30 MR/HR/HV valves.

The thermostatic mixing valve can be installed in any position i.e. upside down or sideways.

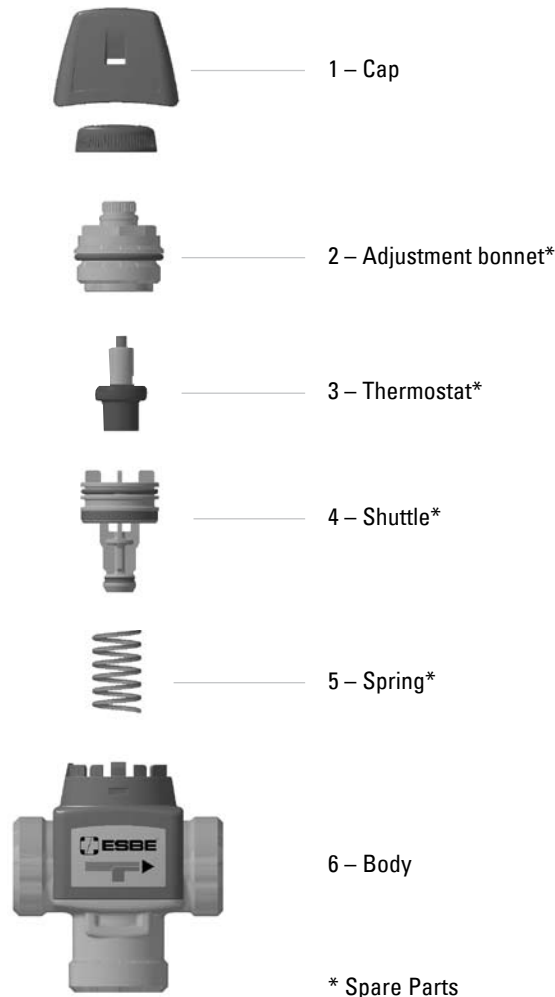
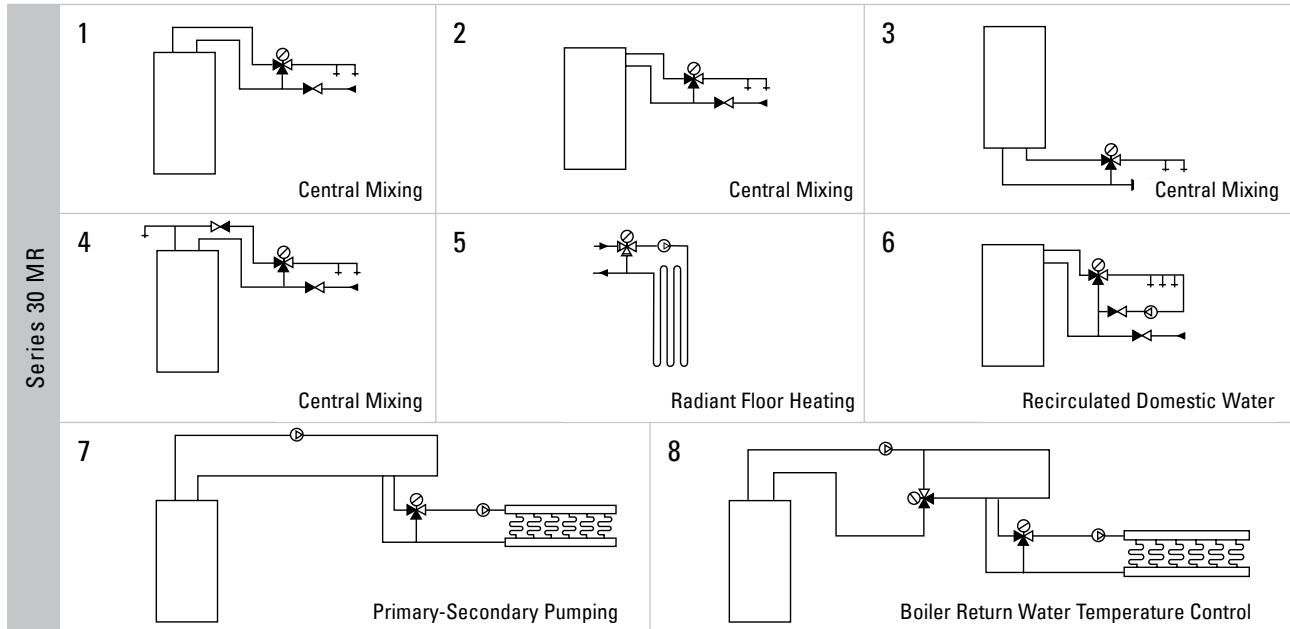

Inspection and maintenance – important!

To ensure proper function, a licensed contractor should verify the mixed outlet temperature annually. The following maintenance procedure should be performed each year and at times when increase in water outlet temperature is observed. Replacement of the valve insert may be required if maintenance and calibration of the valve does not result in correct temperature readings.

To clean and/or restore the valve, shut off water and:

1. Remove cap (item 1) and note position of adjustment wheel.
2. Remove wheel and disassemble valve by removing adjustment bonnet (item 2) and internal parts. (items 3–6).
3. Remove carefully all scaling (calcium deposits) or foreign particles from all parts. Do not use sharp tools or scratch surfaces. Regrease all internal components using silicon grease.
4. Assemble the valve and restore water supply.
5. Calibrate by measuring the mixed outlet temperature.
6. Replace adjustment wheel and cap to prevent tampering.
7. Record service date and valve setting on valve label.



Distributed by:

Danfoss Inc.
6711 Mississauga Road · Suite 410
Mississauga, ON, L5N 2W3 Canada
Telephone: (905) 285 - 2050
Fax: (905) 285 - 2055
E-mail: heatinginfo@danfoss.com
www.na.heating.danfoss.com

Danfoss Inc.
7941 Corporate Drive
Baltimore, MD USA 21236
Tel. (443) 512 - 0266
Fax. (443) 512 - 0270
E-mail: heatinginfo@danfoss.com
www.na.heating.danfoss.com