



**Engineering progress  
Enhancing lives**

# **SKYFORCE Juliet Balcony**

Technical Information

**Windows. Reinvented for modern life.**  
Find out more at [rehau.uk/skyforce](http://rehau.uk/skyforce)



# Contents

## SKYFORCE Juliet balcony

<b>01</b>	<b>General and safety information</b>	<b>3</b>
<b>02</b>	<b>System description</b>	<b>4</b>
<b>03</b>	<b>Profile print</b>	<b>5</b>
03.01	SKYFORCE frame sets	5
03.02	SKYFORCE installation screw	6
03.03	SKYFORCE glass edge protector	6
03.04	Gasket insertion tool	6
<b>04</b>	<b>Fall protection explained</b>	<b>7</b>
04.01	Term definition	7
04.02	Proof of stability	7
04.03	Juliet balcony as fall protection	8
04.04	Fasteners	8
04.05	Fastening examples	8
<b>05</b>	<b>Detail drawings</b>	<b>9</b>
05.01	General information	9
05.02	Horizontal deductions	9
05.03	Vertical deductions	10
05.04	Fastening overview - GENE0	11
05.04.01	Remarks - GENE0	11
05.05	Fastening overview - TOTAL70	12
05.05.01	Remarks - TOTAL70	12
05.06	Installation example - TOTAL70	13
<b>06</b>	<b>Fabrication</b>	<b>14</b>
06.01	Transport and storage of aluminium profiles	14
06.02	Processing	14
06.03	Installation	14
06.04	Cleaning	15
06.05	Coating of aluminium	15
06.06	Cutting the mounting profile	15
06.07	Cutting down standard sets	15
06.08	Drill pattern for screws	16
<b>07</b>	<b>Statics</b>	<b>20</b>
07.01	Determination of loads	20
07.02	Required building regulations:	20
07.03	Barrier load	21
07.04	Glass type	21
07.05	How to read the spreadsheets	22
<b>08</b>	<b>Static tables</b>	<b>24</b>
08.01	Approved reinforcement	24
<b>09</b>	<b>Glass tables</b>	<b>25</b>
<b>10</b>	<b>Notes</b>	<b>29</b>

# 01 General and safety information

## Validity

This information is valid globally.

## Check for the latest version

For safety and the correct use of our products, please check the latest version of our technical information. To get information on the latest version please contact REHAU or visit [www.REHAU.com/ti](http://www.REHAU.com/ti).

## Navigation

At the beginning of this manual you will find a detailed table of contents with titles to the related pages.

## Pictograms and logos



Safety information



Legal information



Important information



Benefits



Information online



Colour varies



Colour black



Colour grey



Colour white



Stainless steel



Anodised aluminium



Package quantities



Seal with silicone



Soft face mallet (non-rebound)

## Distribution of information

Please make sure that your customers (e.g. end consumers) are informed about the correct use and maintenance of this product. The use and maintenance information needs to be made available to the end consumer by you or your customer.

## Correct application

The SKYFORCE Juliet balcony system can only be specified, fabricated and installed as directed in this technical documentation. Any deviation is prohibited.

## Suitability of materials

The current technical documentation needs to be followed for fabrication, installation and use of SKYFORCE. Our technical documentation is based on testing and experience at the time of print. The transfer of this document does not entail any warranty of properties for the listed products. No warranty can be derived from this document. The information contained within this document does not exonerate any user/buyer from checking the suitability of the product for the specific application in question.

## Maintenance and care

In order to ensure the functionality of SKYFORCE over an extended period of time it is necessary to maintain it regularly. SKYFORCE is also used as fall protection, because of this all components need to be kept in proper condition. Any occurring damages need to be assessed by the installation company or the fabricator and replaced if necessary.

Therefore the following maintenance should be carried out at least once a year:

- Check whether there are visible or noticeable damages to any of the gaskets, profiles, windows or fasteners of the french balcony or window.
- If there is damage to the glass, a replacement is necessary.
- Check the surface and clean if necessary.

For these reasons REHAU recommends to share this information about maintenance and care with the end consumer.

## 02 System description

### **Disclaimer**

This product has been manufactured by Onlevel GmbH. REHAU Ltd has no liability for any injury or damage to the property as a result of product or installation failures.

### **The system of invisibility**

SKYFORCE offers an innovative fall protection solution for french balconies. Not only is it one of the first nearly invisible system solutions, but it is one of the best systems on the market due to its quick and easy installation.

The installation only requires the use of standard tools as the inimitable slide and clip technology allows direct fastening to the window profile. The best feature is that only one profile is needed to cover all glass options (length, width and thickness).

### **Benefits at a glance:**

- Complete pre-assembled sets of 1000mm height. Glass thickness 12.76 mm or 21.52 mm
- Other options available as sets or extrusion lengths upon request
- New, visually appealing state of the art system with closed design
- Quick and easy installation
- Concealed fastening system (closed system, all visible parts in the same colour)
- The following surface finishes are available in stock:
  - Mill finish
  - Anodised aluminium E6/C0(EV1)
  - RAL 7016 anthracite grey
  - RAL 9016 white
- Further surface finishes available on request.

## 03 Profile print

### 03.01 SKYFORCE frame sets



Fig. 1: SKYFORCE frame set

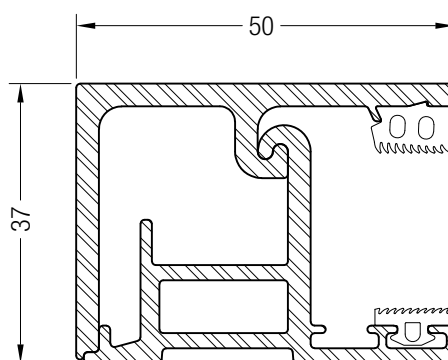

#### 2-Part complete set of jamb rails incl. gaskets, without glass

Glass thickness mm	Glass height mm	Surface finish	Article number
12.76	1000	Mill finish	821107-001
12.76	1000	Anodised aluminium E6/C0(EV1)	821107-002
12.76	1000	RAL 7016 anthracite grey	821107-302
12.76	1000	RAL 9016 white	821107-303
21.52	1000	Mill Finish	821111-001
21.52	1000	Anodised aluminium E6/C0(EV1)	821111-002
21.52	1000	RAL 7016 anthracite grey	821111-302
21.52	1000	RAL 9016 white	821111-303

Table 1: Frame set overview



Please remember the glass edge protectors and fasteners when ordering



The profile lengths for the set is glass height + 5 mm = 1005 mm

### 03.02 SKYFORCE installation screw

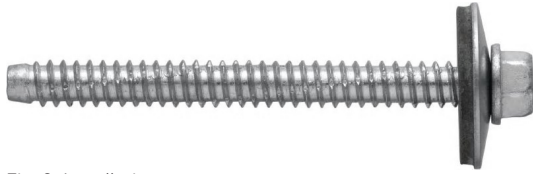

Fig. 2: Installation screw

#### Installation screw Ø 6.3 stainless steel V2A

Length mm	Ø6.3 x 64mm installation screw, matched to the recommended profiles	System	Article number
64	1 bag	GENEO, TOTAL70	821196-001

 12 x screws per bag

Table 2: Installation screw overview

### 03.03 SKYFORCE glass edge protector

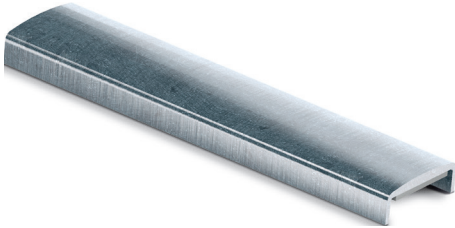

Fig. 3: Glass edge protector

#### Glass edge protector including glass mounting tape

Width mm	Glass thickness mm	Length mm	Surface finish	Article number
16	12.76	1000	Anodised aluminium E6/C0(EV1)	821179-100
16	12.76	1500	Anodised aluminium E6/C0(EV1)	821179-150
24	21.52	3000	Anodised aluminium E6/C0(EV1)	821188-300

 1

Table 3: Glass protector overview

### 03.04 Gasket insertion tool

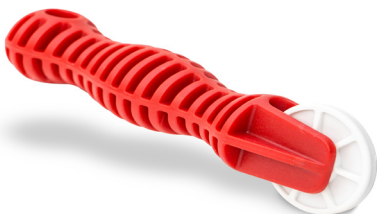

Fig. 4: Gasket insertion tool

Description	Artice number
Gasket insertion tool	821169-001 

 1

Table 4: Gasket insertion tool overview

## 04 Fall protection explained

### 04.01 Term definition

Many countries have fall protection requirements for heights of 0.5 - 1 m. For the meaning of barrier height and fall height see Fig. 5.

### 04.02 Proof of stability

Fall protection window units need to be approved by a structural engineer. Fall protection is a property of the window unit as a whole. This includes glazing, the profile system, mullion or transom and their connections including the fastening of the unit to the building structure. For the connections the characteristic load-bearing capacity  $F_{Rk}$  of the T-connection is essential. The verification for the connectors can be found in VI from 1.10.2018 "Absturzsicherheit - Verbinder für absturzsichernde Fenster".

From a fall height of 0.5 - 1 m or 1.1 m the window needs to adhere to the fall protection guidelines. This includes a window mounted juliet balcony. This means a structural engineer needs to make sure that the complete unit and its installation is structurally sound and fit for purpose. All critical parts must be coordinated with each other and must follow the local and country specific rules and regulations.

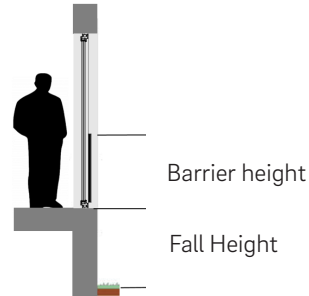

Fig. 5: Term definition



A juliet balcony for fall protection falls under the term barrier.



A structural engineer must check the complete installed window unit is structurally sound and fit for purpose

**04.03 Juliet balcony as fall protection**

The glass for SKYFORCE is categorised as fall protection according to DIN 18008 Part 4, Cat. A. This is with glass edge protection on top and without glass edge protection connected on either side. The glass balcony consists of double-sided linearly mounted glass, held in place by an aluminium profile with EPDM gaskets on either side. SKYFORCE has been tested by the German Institute for Construction Engineering in Berlin, AbP Nr. VT 17-083.1P.

The juliet balcony system is delivered without glass. Please see table T1 to find the correct glass for your application. Glass can be ordered directly at a glass supplier of choice.

 The proper fastening of a window or door with fall protection needs to be checked by a structural engineer.

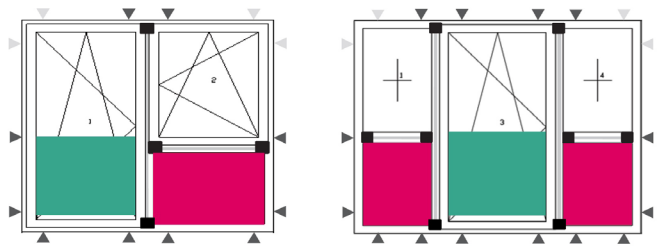
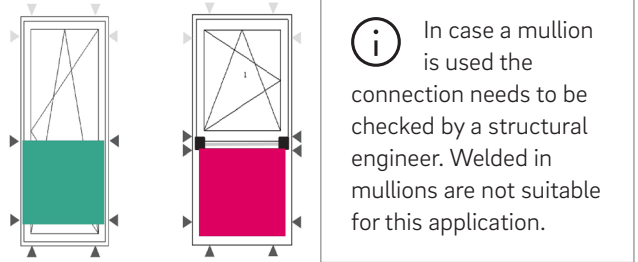

**04.04 Fasteners**

The fastening of the window or door unit to the building can be done using appropriate fasteners. The load transfer from the juliet balcony through the window/door unit into the building framework needs to be proven. Fasteners offering such proof are available from:

- Fa. Würth
- SFS intec
- Illbuck
- Innoperform
- Ejot

Heed the advice of the respective supplier.

**04.05 Fastening examples**

The maximum distance between fastening points is 700 mm, the distance from the inner corner of the profiles is 150mm. See also - installation guidelines. **The units displayed need to be checked for suitability for the use as fall protection by a structural engineer.**

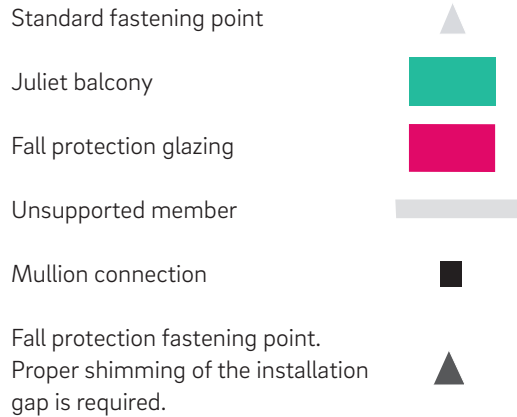

 Because of a danger to life and limb with fall protection applications the following things need to be available in order to be safe:

- Test certificates for all components
- A structural engineering certificate for the individual project
- A compliance certificate for the end consumer / home owner in addition to the above it needs to be verified that only approved REHAU window systems are used with SKYFORCE.

# 05 Detail drawings

## 05.01 General information

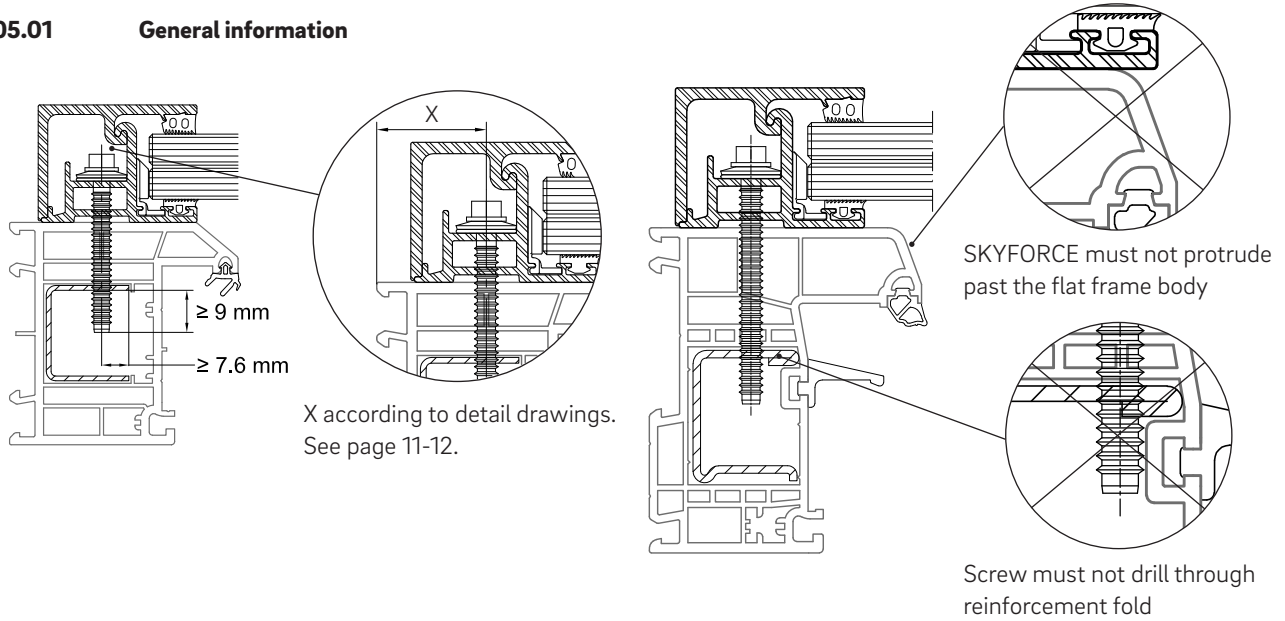

## 05.02 Horizontal deductions

### Single units

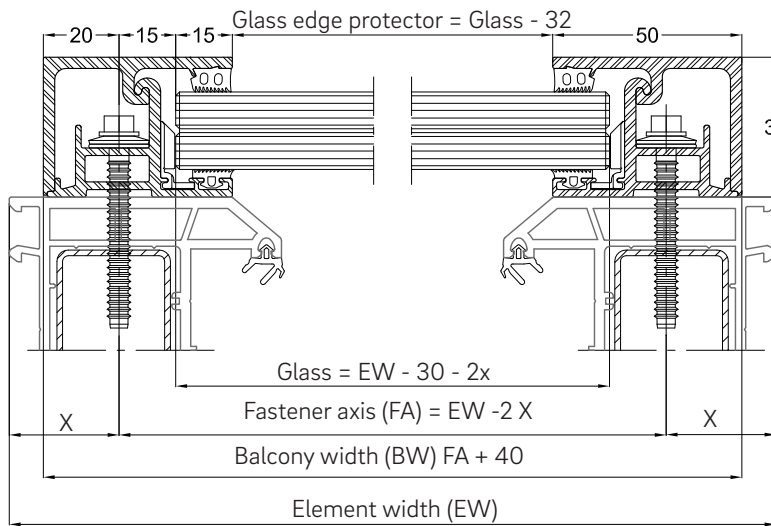

### Legend

Glass	(Glass width)	EM - 30 - 2X
FA	(Fastener axis)	EM - 2X
BW	(Balcony width)	EM - 2X + 40
EW	(Element width)	-
X	(Finished aperture + SKYFORCE cap Install)	(Min. 5) + 20

Table 5: Horizontal deduction equations

ⓘ Glass dimensional tolerance:  
 Horizontal: width tolerance +4/0 mm  
 Vertical: height tolerance +3/0 mm.

**05.03 Vertical deductions**

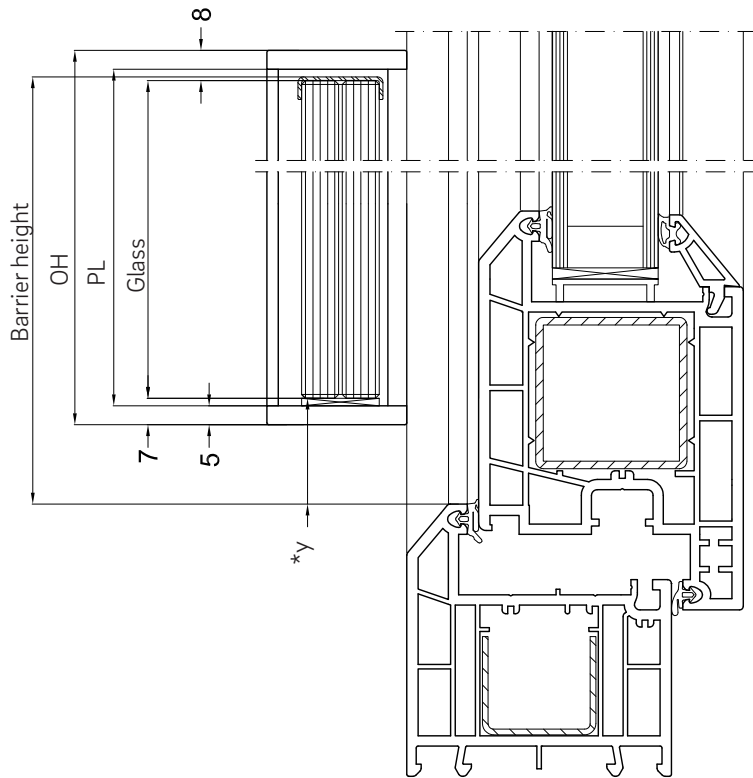

\* In case the distance "Y" between the frame top edge and glass bottom edge is greater than 30mm an additional glass edge protector needs to be used for the bottom glass edge.

**i** The frame top edge is the reference point for the barrier height.

**Vertical deductions**

Glass	(Glass height)	
PL	(Profile length)	Glass + 5 mm
OH	(Overall height)	Glass + 15
Y	(Distance frame - glass)	Barrier height - PL - 4 mm

Table 6: Vertical deduction equations

**05.04 Fastening overview GENE0**

- The SKYFORCE elements need to be positioned in a way that allows for the entire aluminium section to sit flush on the frame profile.
- The possible screw positioning range is shown below
- Fastening screw  $\varnothing$  6.3 x 64 mm, 821196-001.
- Pre-drill for steel reinforcement thickness:
  - **1.5 mm** with  $\varnothing$  5 mm,
  - **2-5 mm** with  $\varnothing$  5.3 mm
  - **6 mm** with  $\varnothing$  5.5 mm
  - **7-10 mm** with  $\varnothing$  5.7 mm.
- There is no need to open up the PVC with a larger drill.

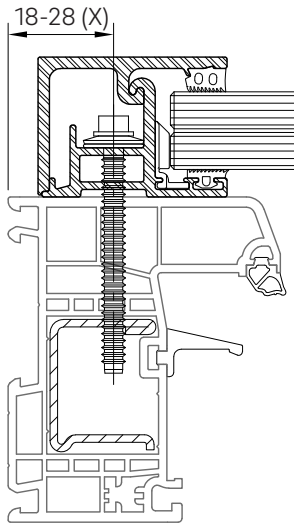

Frame 72

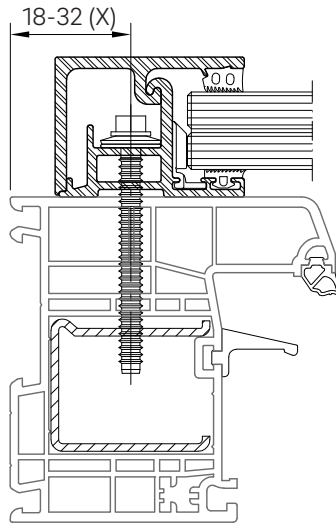

Frame 86

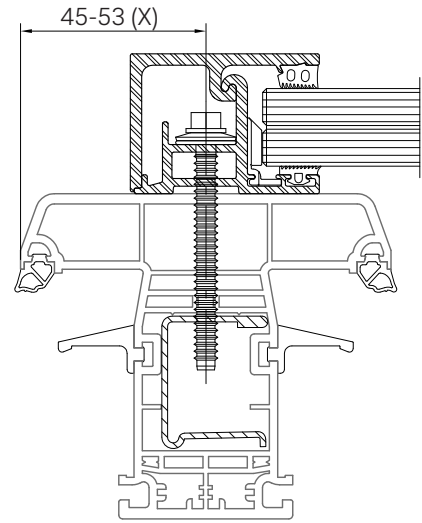

Mullion 98

**05.04.01 Remarks GENE0**

**Unsuitable for use with SKYFORCE**

**Reason**

GENE0 without reinforcement

Insufficient static fastening

Table 7: GENE0 remarks

**05.05 Fastening overview TOTAL70**

- The SKYFORCE elements need to be positioned in a way that allows for the entire aluminium section to sit flush on the frame profile.
- The possible screw positioning range is shown below
- Fastening screw  $\varnothing$  6.3 x 64 mm, 821196-001.
- Pre-drill for steel reinforcement thickness:
  - **1.5 mm** with  $\varnothing$  5 mm
  - **2-5 mm** with  $\varnothing$  5.3 mm
  - **6 mm** with  $\varnothing$  5.5 mm
  - **7-10 mm** with  $\varnothing$  5.7 mm.
- There is no need to open up the PVC with a larger drill.

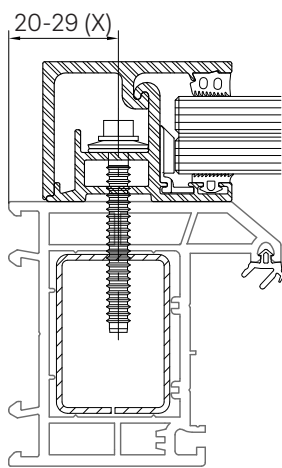

Frame 72mm 3-Chamber

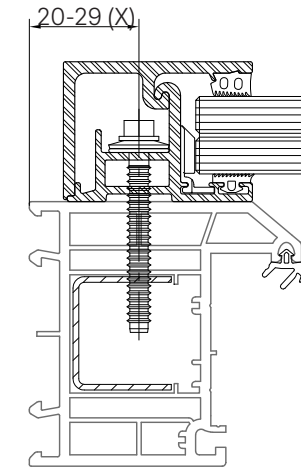

Frame 72mm 5-Chamber

**05.05.01 Remarks TOTAL70**

**Suitable for use with SKYFORCE**

72 mm 3 - chamber	Reinforcement: 261958 (1.5mm)
72 mm 5 - chamber	Reinforcements: 336894 (1.5mm) 336895 (2mm)

**Unsuitable for use with SKYFORCE**

Reason
T mullion

No mechanical joint option. T mullion needs to be mechanically jointed

Table 8: TOTAL70 remarks

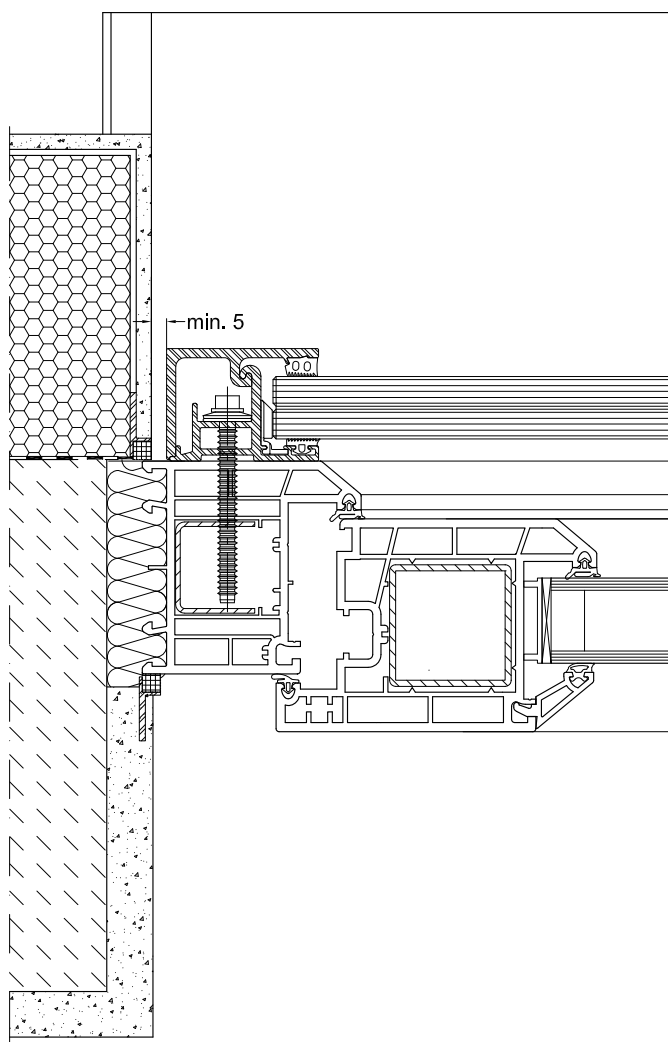
**05.06 Installation example - TOTAL70**

The installation of SKYFORCE happens after all building envelope works have been finished. A minimum distance of 5 mm between the finished aperture and the SKYFORCE are needed to install the aluminium cap. The glass installation is done from the exterior, make use of scaffolding where needed. The combined weight of glass and installer need to be considered to choose suitable scaffolding.

## 06 Fabrication

### 06.01 Transport and storage of aluminium profiles

The SKYFORCE sets are packed into cardboard boxes and therefore sufficiently protected against mechanical influence. Mill finished extrusion lengths of aluminium need special attention in regards to transport and storage. Although transport, handling or storage issues are of little influence to the function of the aluminium profiles they will show negative effect after the surface finish has been applied. Possible issues are water spots, corrosion, scratches, rub marks, dents or bends.

Storage must not allow the profiles to be dented, scratched or bent. Therefore please make sure to use support material made of soft material such as (untreated) timber or plastic. Under no circumstance should the profiles stand on concrete flooring or get in contact with brickwork, plaster, steel or other metals.

Mill finish extrusion length aluminium profiles are to be kept safe from moisture. Therefore:

- Unpack them immediately after receipt, use gloves to prevent the transfer of any moisture or finger prints onto the material.
- Avoid direct contact between the profile and water.
- Pay attention to putting "cold" profile in storage as it might build condensation.
- Use a soft cloth to wipe down any wet profile.
- No unprotected storage of aluminium profile outside, keep them inside and free of dust. Keep dry and ventilated in a room with relatively low humidity.
- Assure good ventilation of the storage facility and replace wet paper inter layers with dry ones.
- Aluminium profiles should not be stored for extended periods of time, they should be used as soon as possible due to the potential of corrosion over time.
- If stored over longer periods of time they should be sprayed with corrosion protection.

### 06.02 Processing

In order to get the best possible result when cutting the profile it is recommended to use a saw with adjustable cutting and blade speed. Generally the correct cutting angle and proper spanning of the profile needs to be observed. In order to avoid pressure points and or scratches it is recommended to assure clean contact surfaces of machinery and profile. The profile surface should be protected using protective film.

We recommend the following saw blade:

- Blade type: HM
- Diameter: 300 - 400 mm
- Tooth shape: Trapezoid-flat, negative
- Tooth pitch: Fine
- RPM: 3000 - 4000 min<sup>-1</sup>
- Cutting speed: 50 - 60 m/s

Please adjust the cutting speed in a way that allows the cut material to be transported away to avoid deformation of the profile. Suitable coolant and/or lubricant is recommended.

The sharpness of the blade is essential because a dull blade could create too much heat and collect melted material between the teeth which would negatively impact the result.

Aluminium should have dedicated saw blades that must not be used for cutting any other material, otherwise there is a chance that the aluminium could get contaminated with other metals. Any holes can be drilled with standard HSS or HM drill or router bits.

The profiles need to be cut at the time they are needed. In order to avoid any future de-burring or damages it is recommended to cut into the profile starting at the visible surface. In the case of bare aluminium showing at the cut the surface needs to be touched up to avoid corrosion.

### 06.03 Installation

Aluminium parts must not be subjected to scratch or hit stresses. Therefore special care needs to be taken throughout storage and transportation.

The final installation of the juliet balconies (glass and cover profile) should be the last step of construction after all external building work is done. This is to avoid any dirt (especially plaster or mud) getting onto the profile. Any plaster, brick or tile dust can attack the surface finish of the aluminium profile. Should this happen the contaminants need to be removed with water immediately.

If SKYFORCE is installed before the end of other building construction it is recommended to use protective film. Due to the ageing process of the adhesive used on such films, they should not stay on the profile for extended periods of time. The adhesive needs to be free from chlorinated hydrocarbon as these are often used in polish removers and paint strippers.

**i** IMPORTANT: A gap of min. 5mm is needed between SKYFORCE and the building surfaces in order to install the cover profile!

**06.04 Cleaning**

For cleaning of the aluminium please refer to specialised literature provided by the aluminium industry.

Before you start cleaning the profile you should try the solution on a separate part. If the parts are cleaned regularly soapy water is sufficient.

**06.05 Coating of aluminium**

Filiform corrosion:

Objects that are exposed to chloride in an atmosphere with relatively high humidity are subject to this type of corrosion when powder coated. Filiform corrosion can be observed in coastal and industrial areas and swimming pools. According to current knowledge this can only be avoided if the aluminium profile is pre treated, for example by means of anodisation. The same applies for cut and drilled surfaces.

Any damage or machining of treated and finished surfaces is strictly to be avoided! The powder coater needs to be informed if any of the above special circumstances apply in order to choose the correct pre treatment of the profile. This needs to be clear at the time of order.

If parts of different materials or surface treatments (e.g. acrylic coat and powder coat) are combined it is necessary to get pre approval from the builder by means of samples. Especially with any metallic effect as a difference in appearance is unavoidable.

**06.06 Cutting the mounting profile**

The mounting profile can be cut from the following:  
 - Standard set Lengths  
 - 5m extrusion lengths

**06.07 Cutting down standard sets**

The set lengths have additional drill holes in order to use them for at least the next smaller size. For the 500 mm set it is even possible to cut down to a length of 300 mm. Shortening is possible in 50 mm steps. Set lengths = glass height. The set sizes have the following drill patterns (H = glass height):

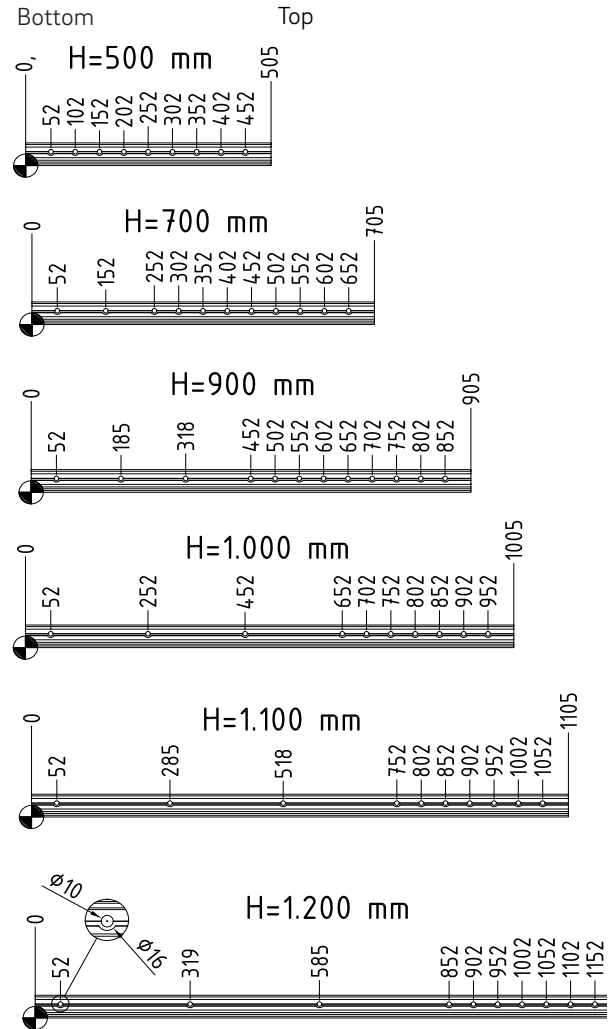

Fig. 5: Cutting down standard sets

**06.08 Drill pattern for screws**

The shortening of standard set sizes is done according to the following pattern:

Set	500		700		900		1000		1100		1200			
Grid sizes for profile length (PL) in mm	PL in mm	Screw count	PL in mm	Screw count	PL in mm	Screw count	PL in mm	Screw count	PL in mm	Screw count	PL in mm	Screw count		
	305	5	505	5	705	6	905	6	1005	6	1105	6		
	355		555		755		955		1055		1155			
	405		605		805		1005		1105		7		1205	7
	455		655		855									
	505		705		905		7							
Fastening screw distance in mm														
			If distance > 300 mm, then 7 screws		If distance > 300 mm, then 7 screws	If distance > 300 mm, then 7 screws								

Fig 6: Number of screws and distance

Example: Set size 1000 mm, shortened to 900 mm,  
Drill for 6 screws according to glass height H = 900 mm

Length of profile:	Glass height = 900 mm + 5 mm = 905 mm
Deduction:	Profile length 1005 mm – 905 mm = 100 mm
Screw distance from top:	905 mm – 53 mm = 852 mm
Fastening:	52 mm, 252 mm, 452 mm, 652 mm, 752 mm, 852 mm

Table 9: Screw positioning example

The profile length for the set is glass height + 5 mm

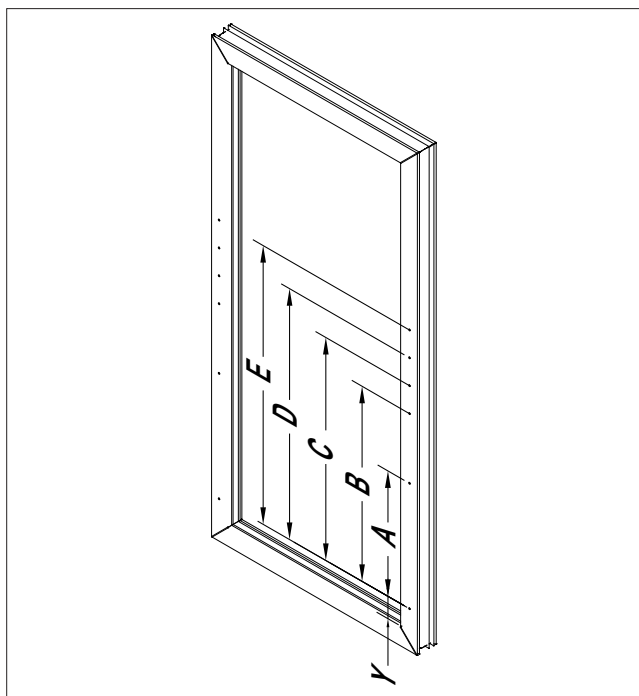

**1.** Pre-drill frame members (For measurements see page 16, Table 1)

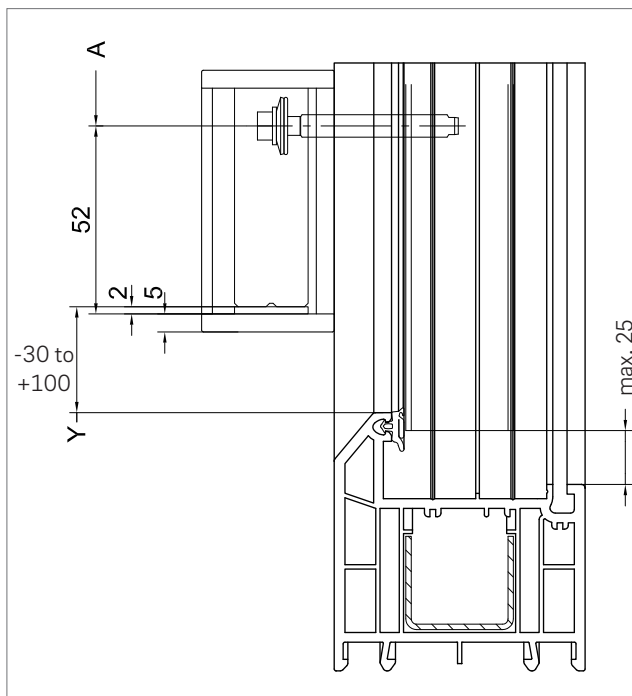

If  $Y > 30$  mm the use of an additional glass edge protector on the bottom edge of the glass is necessary. Maximum distance 100mm. In case of negative value ( $Y < 0$ mm) the frame reinforcement length needs to be considered.

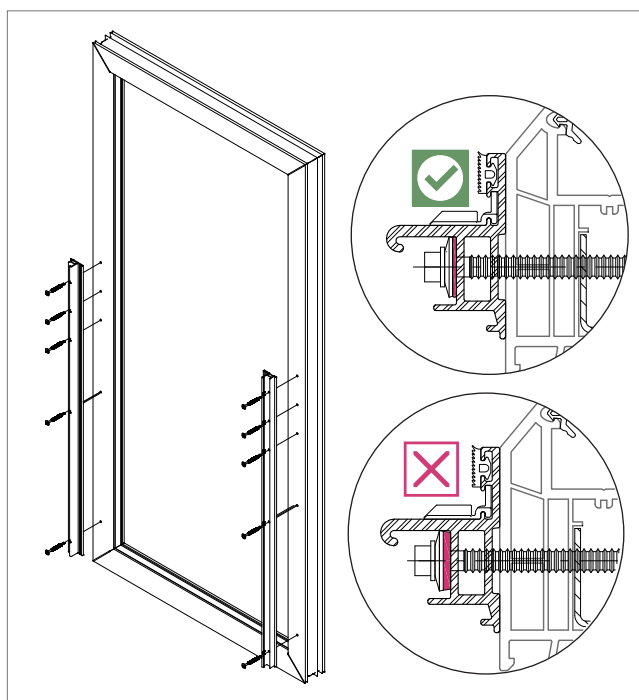

**2.** Fastening of the profile with installation screws. The maximum fastening torque is 4 Nm. In any case the screws need to be fastened in a manner that the washer gasket is touching and slightly compressed.

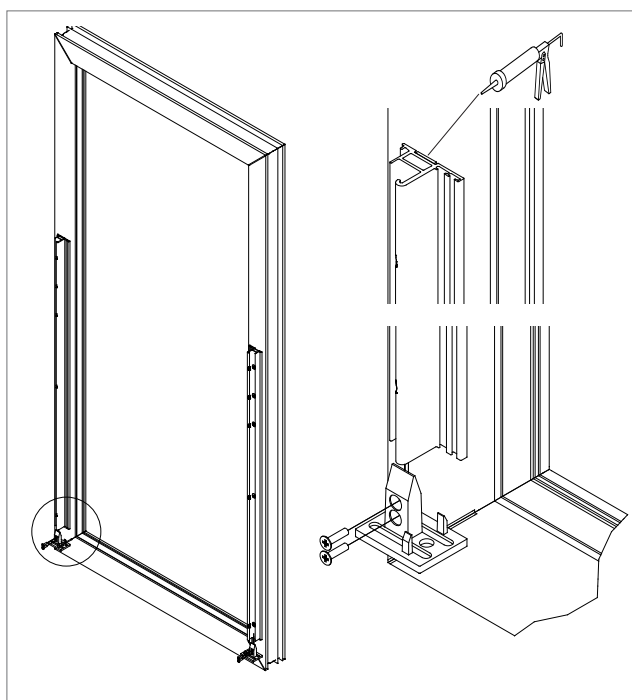

**3.** Seal up the top groove of the profile. Installation of the end cap (Pre-installed with sets).

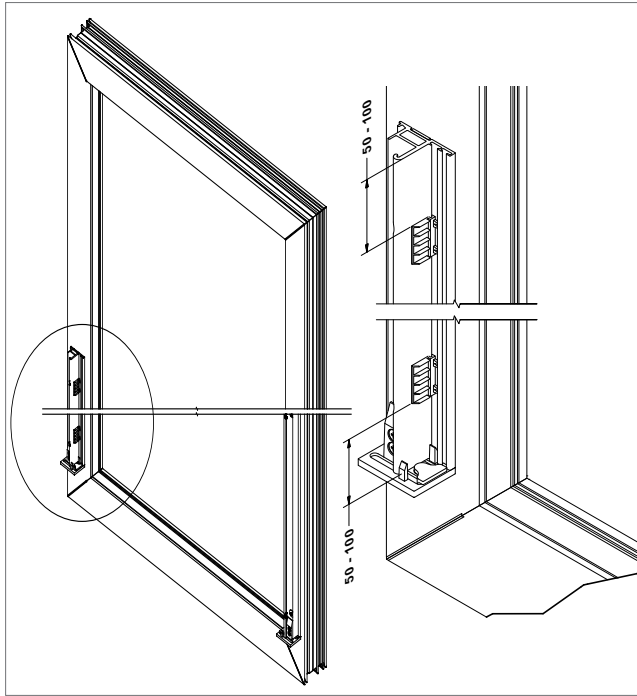

**4.** Insert glazing gasket into the frame mounted profile and install the glass carriers and glazing blocks (pre - installed with sets).

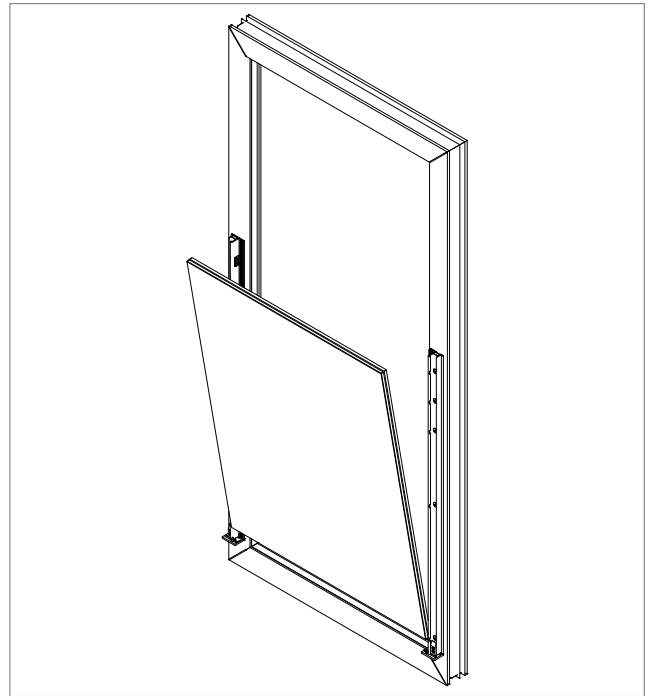

**5.** Insert glass

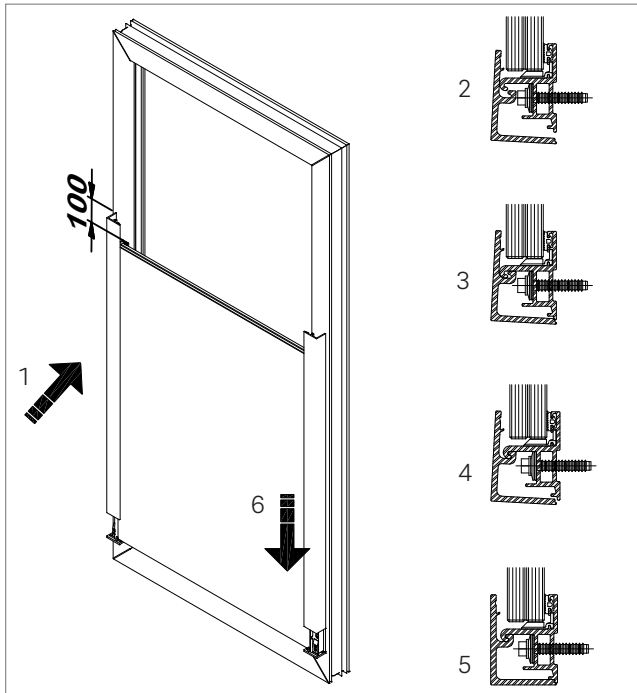

**6.** Install cover profile

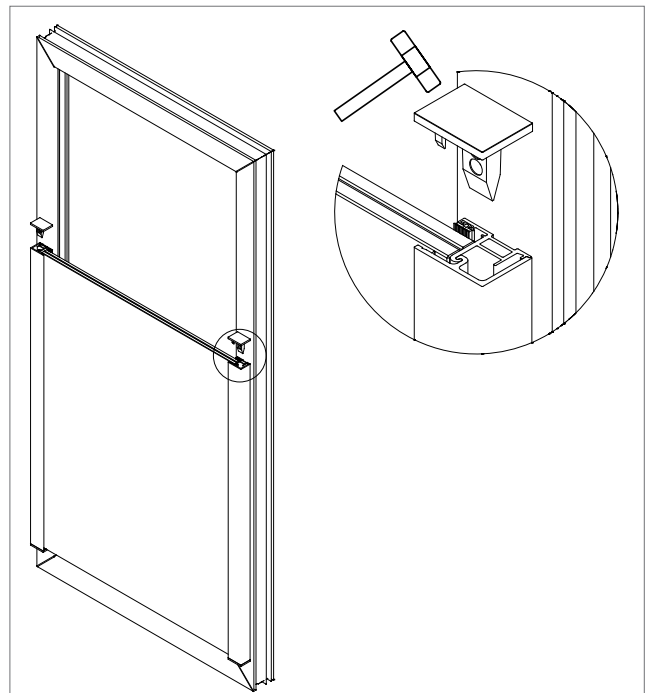

**7.** Insert end caps.

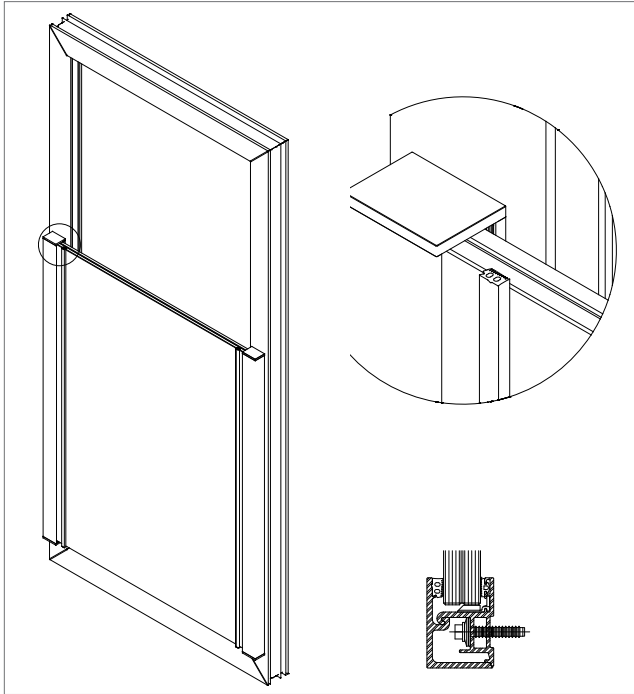

**8.** Insert gasket into cover profile using the gasket insertion tool art. 1821169.

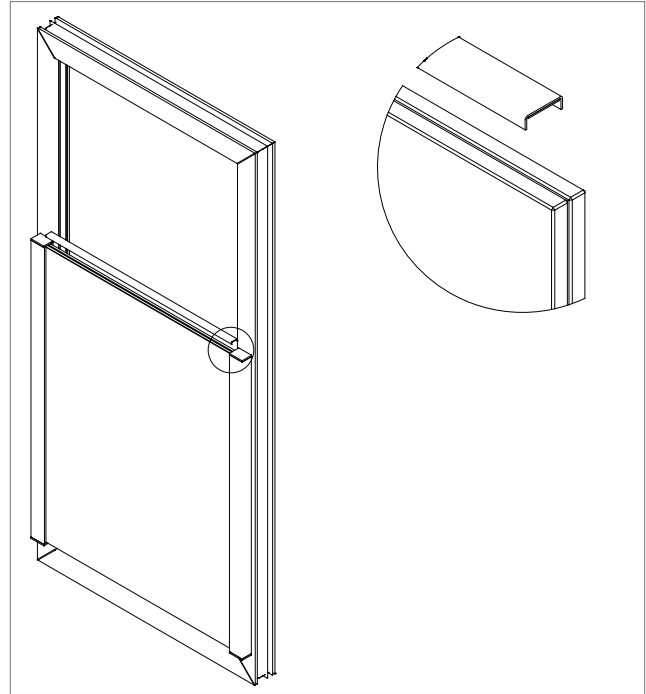

**9.** Remove the film from the glass edge protector tape and glue it to the top of the glass.

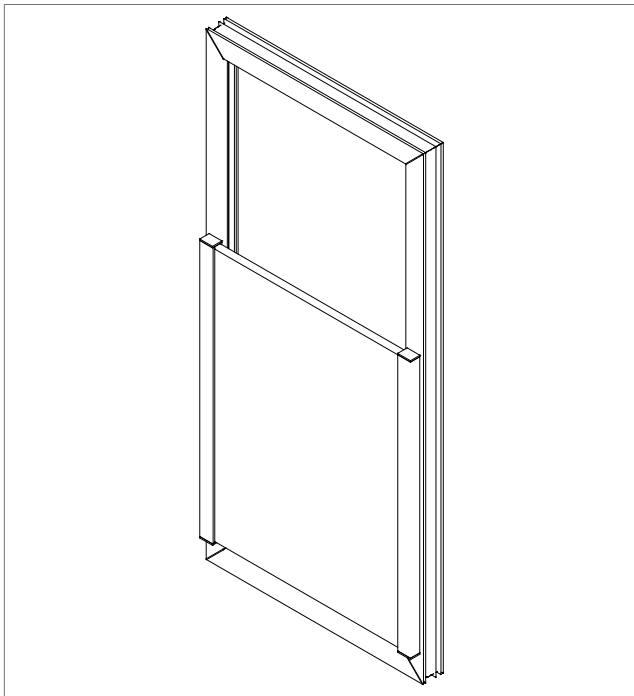

**10.** Finished

## 07 Statics

### 07.01 Determination of loads

In order to build a french balcony it is necessary to determine the wind and barrier load. Both are necessary for SKYFORCE.

Wind load:

For static calculation it is necessary to consider the wind load according to DIN EN 1991-1-4 (NA). The wind pressure  $w_e$  includes the velocity pressure  $q_p$  and the external pressure coefficient  $c_{pe}$ :

$$w_e = q_p \cdot c_{pe}$$

The external pressure coefficient  $c_{pe}$  describes the effect of wind on the glass balcony. It depends on the size of the glass balcony, the building shape and the position of the glass on the building. In this technical manual we assume the worst case scenario with an external pressure coefficient  $c_{pe}$  of 1.7.

### 07.02 Required building regulations:

Design and installation must be in accordance with BS 6180:2011 and Approved Document K.

- Further details regarding minimum heights can be found in BS 6180:2011 Table 1.
- Further details regarding minimum horizontal imposed loads can be found in BS 6180:2011 Table 2.

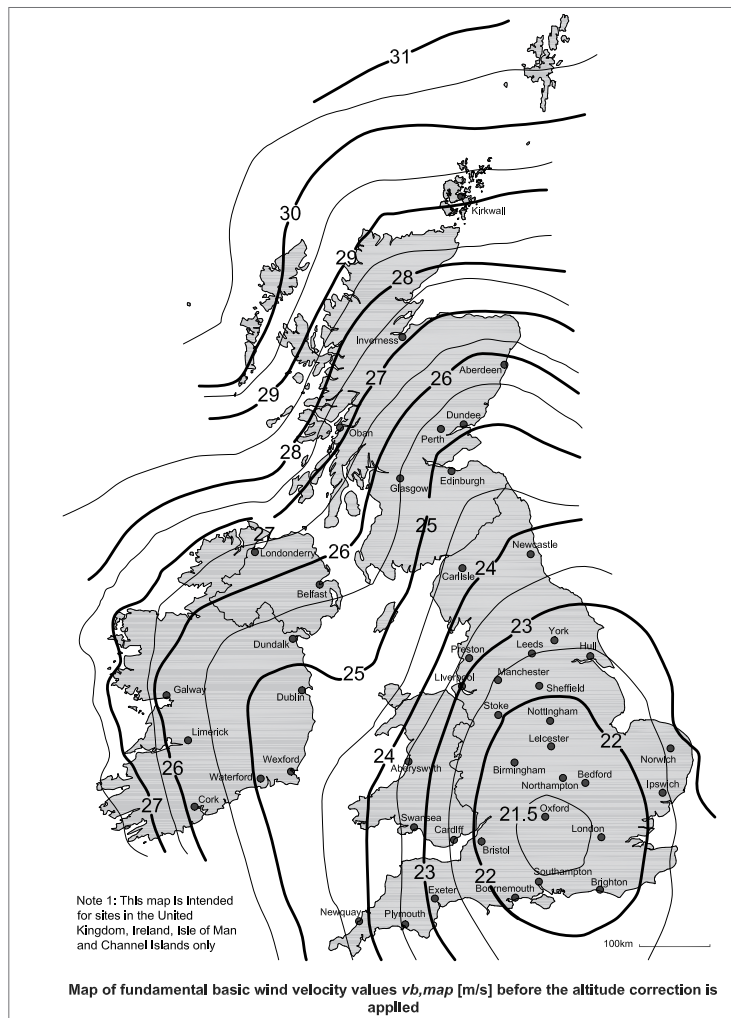

Fig. 7: Wind load map

### 07.03 Barrier load

The horizontal payload is determined by DIN EN 1991-1-1/NA:2010-12 or by the Architect / Structural Engineer.

Category	Description	Examples of use	Horizontal payload $q_k$ kN/m
A	Residential buildings	Residential houses and apartments	0.5
B	Public buildings	Hospital rooms, hallways and kitchens, hotels; care facilities	1.0
C	Buildings with high amounts of people gathering	Concert halls, terraces and entrances	2.0

Table 10: Horizontal payload on juliet balcony  $q_k$  in kN/m



Because of the fall protection aspect the horizontal payload needs to be considered for the construction of the window/door unit.

### 07.04 Glass types

The below mentioned glass and interlayer thickness can be exceeded. The glass bite is 15 mm and must not be less. All glass edges are to be done in KGN<sup>1)</sup> quality at the minimum. Either VSG<sup>2)</sup> from TVG<sup>3)</sup>, or VSG from ESG<sup>4),5)</sup> are used. PVB interlayer according to table 11. We recommend polished edges KPO<sup>6)</sup> for at least the bottom edges of the glass.



**Glass tolerance**  
Horizontal: width +4/0 mm  
Vertical: Height +3/0 mm



The 2-part set of jamb rails for glass thickness 12.76 and 21.52 mm is in stock. For other parts please contact your REHAU sales office.

Category acc. to DIN 18008-4	Glass support	Glass makeup	Glass thickness (mm)
A	2 - sided left and right	66.2 or 66.4 VSG from ESG(-H)	12.76 or 13.52
		1010.4 VSG from ESG(-H)	21.52
		66.2 or 66.4 VSG from TVG	12.76 or 13.52
		1010.4 VSG from TVG	21.52

Table 11: Glass make up

1) KGN: Ground edges (not polished)

2) VSG: Laminated glass with PVB interlayer

3) TVG: Heat strengthened glass

4) ESG: Toughened float glass

5) Instead of ESG it is permitted to use ESG-H

6) KPO: Polished edges

7) ESG-H: Toughened heat soaked float glass

**07.05 How to read the spreadsheets**

No.	Step
1	Know your wind load (provided by the planner)
2	Determine the horizontal payload (table 10)
3	Take the necessary screw retention, given in tables 14-16 and find the correct reinforcement in table 17
4	Use the horizontal payload as well as the wind load from tables 14-16 and compare the glass width and height with table 18.0 to 18.3 to find the correct glass make up

Table 12: How to read the spreadsheets

No.	Step	Result
1	Consult planner/architect for wind load of the specific SKYFORCE application	1800 Pa
2	Horizontal barrier load category A (Residential building)	Barrier load 0.5 kN/m
3	Width 1250 mm x height 1000 mm Table 8 for reinforcements	$F_{t,Ed} = 1.91\text{kN/m}$ 2.0 mm
4	Glass tables for glass 1250 x 1000 mm Table 18.1, wind load 1800 Pa  Or Table 18.2 / 18.3, wind load 1800 Pa	VSG from TVG 1010.4, with 21.52 mm. Usable for standard set 21.52 mm

Table 13: Example 1

# 08 Static tables

Retention force Installation screw  $F_{t,Ed}$

Based on the glass height the following retention forces have been calculated. The screw retention including the deduction of the safety factor  $F_{reduced\ retention}$  needs to be bigger than the calculated retention force needed  $F_{t,Ed}$ . See also table 17 for the colour code regarding  $F_{reduced\ retention}$ .

Steel Thickness (mm)	1.5	2.0	2 x 1.5	2 x 2.0							
<b>Residential buildings (0.5 kN/m barrier load)</b>											
<b>Glass height of juliet balcony 1000mm</b>											
Width	500	750	1000	1250	1500	1750	2000	2250	2500	2750	3000
Windload Pa											
≤ 1000	0.43	0.64	0.85	1.06	1.28	1.49	1.70	1.91	2.13	2.34	2.55
≤ 1200	0.51	0.77	1.02	1.28	1.53	1.79	2.04	2.30	2.55	2.81	3.06
≤ 1400	0.60	0.89	1.19	1.49	1.79	2.08	2.38	2.68	2.98	3.27	3.57
≤ 1600	0.68	1.02	1.36	1.70	2.04	2.38	2.72	3.06	3.40	3.74	4.08
≤ 1800	0.77	1.15	1.53	1.91	2.30	2.68	3.06	3.44	3.83	4.21	4.59
≤ 2000	0.85	1.28	1.70	2.13	2.55	2.98	3.40	3.83	4.25	4.68	5.10
≤ 2200	0.94	1.40	1.87	2.34	2.81	3.27	3.74	4.21	4.68	5.14	5.61
≤ 2400	1.02	1.53	2.04	2.55	3.06	3.57	4.08	4.59	5.10	5.61	6.12
≤ 2600	1.11	1.66	2.21	2.76	3.32	3.87	4.42	4.97	5.53	6.08	6.63
≤ 2800	1.19	1.79	2.38	2.98	3.57	4.17	4.76	5.36	5.95	6.55	7.14
≤ 3000	1.28	1.91	2.55	3.19	3.83	4.46	5.10	5.74	6.38	7.01	7.65

Table 14: Residential Buildings - Tension load of installation screw

<b>Public buildings (1.0 kN/m barrier load)</b>											
<b>Glass height of juliet balcony 1000mm</b>											
Width	500	750	1000	1250	1500	1750	2000	2250	2500	2750	3000
Windload Pa											
≤ 1000	0.48	0.72	0.96	1.20	1.44	1.68	1.92	2.16	2.40	2.64	2.88
≤ 1200	0.51	0.77	1.02	1.28	1.53	1.79	2.04	2.30	2.55	2.81	3.06
≤ 1400	0.60	0.89	1.19	1.49	1.79	2.08	2.38	2.68	2.98	3.27	3.57
≤ 1600	0.68	1.02	1.36	1.70	2.04	2.38	2.72	3.06	3.40	3.74	4.08
≤ 1800	0.77	1.15	1.53	1.91	2.30	2.68	3.06	3.44	3.83	4.21	4.59
≤ 2000	0.85	1.28	1.70	2.13	2.55	2.98	3.40	3.83	4.25	4.68	5.10
≤ 2200	0.94	1.40	1.87	2.34	2.81	3.27	3.74	4.21	4.68	5.14	5.61
≤ 2400	1.02	1.53	2.04	2.55	3.06	3.57	4.08	4.59	5.10	5.61	6.12
≤ 2600	1.11	1.66	2.21	2.76	3.32	3.87	4.42	4.97	5.53	6.08	6.63
≤ 2800	1.19	1.79	2.38	2.98	3.57	4.17	4.76	5.36	5.95	6.55	7.14
≤ 3000	1.28	1.91	2.55	3.19	3.83	4.46	5.10	5.74	6.38	7.01	7.65

Table 15: Public buildings - Tension load of installation screw

Buildings with high amounts of people gathering (2.0 kN/m barrier load) Glass height of juliet balcony 1000mm												
Width	500	750	1000	1250	1500	1750	2000	2250	2500	2750	3000	
Windload Pa												
≤ 1000	0.88	1.32	1.76	2.20	2.64	3.08	3.52	3.96	4.40	4.84	5.28	
≤ 1200	0.90	1.34	1.79	2.24	2.69	3.14	3.59	4.03	4.48	4.93	5.38	
≤ 1400	0.91	1.37	1.82	2.28	2.74	3.20	3.65	4.11	4.56	5.02	5.48	
≤ 1600	0.93	1.39	1.86	2.32	2.79	3.25	3.72	4.18	4.65	5.11	5.57	
≤ 1800	0.94	1.42	1.89	2.36	2.84	3.31	3.78	4.26	4.73	5.20	5.67	
≤ 2000	0.96	1.44	1.92	2.40	2.89	3.37	3.85	4.33	4.81	5.29	5.77	
≤ 2200	1.02	1.54	2.05	2.56	3.08	3.59	4.10	4.62	5.13	5.64	6.15	
≤ 2400	1.09	1.63	2.18	2.72	3.27	3.81	4.36	4.90	5.45	5.99	6.53	
≤ 2600	1.15	1.73	2.30	2.88	3.46	4.04	4.61	5.19	5.76	6.34	6.92	
≤ 2800	1.22	1.82	2.43	3.04	3.65	4.26	4.87	5.47	6.08	6.69	7.30	
≤ 3000	1.28	1.92	2.56	3.20	3.84	4.48	5.12	5.76	6.40	7.04	7.68	

Table 16: Buildings with high amounts of people gathering - Tension load of installation screw

### 08.01 Approved reinforcement

The previous table shows reinforcements suitable for the installation of this fall protection system according to expert opinion S-WUE / 190351. The retention forces depend on wall thickness, material properties, shape and tolerances of the reinforcement. The approved reinforcements are an essential part of the fall protection system. In case of use of any non-REHAU reinforcements the approval of the system expires.

All determined retention forces are lowered by a safety factor of  $Y_M = 1.5$  and are displayed in the previous tables.

All reinforcements used need to be supported by an internal wall of the profile. It is not sufficient if the reinforcements are only supported by nubs.

The reduced screw retention forces shown in table 14-16 are using a colour scheme and need to be double checked with table 17. The screws can be used if  $F_{\text{reduced retention}} \geq F_{t,Ed}$ .

<b>Steel wall thickness</b>	D	mm	1.5	2.0	2 x 1.5 <sup>1)</sup>	2 x 2.0 <sup>1)</sup>
<b>Screw retention</b>	$F_{\text{retention}}$	kN	2.10	3.15	3.73	4.76
<b>Safety factor</b>	$Y_M$	-	1.5	1.5	1.5	1.5
<b>Screw retention reduced by <math>Y_M</math></b>	$F_{\text{reduced retention}}$	kN	1.40	2.10	2.48	3.17

Table 17: Approved reinforcements

<sup>1)</sup>Double folded steel, wall thickness at screw position 2 x 1.5 mm or 3 mm

<sup>2)</sup>Double folded steel, wall thickness at screw position 2 x 2.0 mm or 4 mm



In case of use of any non-REHAU reinforcements the approval of the system expires.





Maximum permissible wind load in kN/m <sup>2</sup>																															
Height	Wind load	Width																												Glass Type	Thickness
		mm																													
mm	kN/m <sup>2</sup>	500	600	700	800	900	1000	1100	1200	1300	1400	1500	1600	1700	1800	1900	2000	2100	2200	2300	2400	2500	2600	2700	2800	2900	3000	VSG from ESG or ESG-H	mm		
		300	0.5	4.50																											
1.0	4.50																														
2.0	4.50																														
400	0.5	4.50																													
	1.0	4.50																													
	2.0	4.50																													
500	0.5	4.50	4.50	4.50	4.50	4.50	4.50	3.50	2.75	2.25	2.00																				
	1.0	4.50	4.50	4.50	4.50	4.50	3.50	2.75	2.00	1.50	0.75																				
	2.0	4.50	4.50	4.50	4.25	2.00	0.25																								
600	0.5	4.50	4.50	4.50	4.50	4.50	4.50	3.50	2.75	2.25	2.00																				
	1.0	4.50	4.50	4.50	4.50	4.50	3.75	2.75	2.25	1.75	1.25																				
	2.0	4.50	4.50	4.50	4.50	2.50	1.00																								
700	0.5	4.50	4.50	4.50	4.50	4.50	4.50	3.50	3.00	2.25	2.00																				
	1.0	4.50	4.50	4.50	4.50	4.50	3.75	3.00	2.25	1.75	1.50																				
	2.0	4.50	4.50	4.50	4.50	3.00	1.25	0.25																							
800	0.5	4.50	4.50	4.50	4.50	4.50	4.50	3.50	3.00	2.25	2.00																				
	1.0	4.50	4.50	4.50	4.50	4.50	3.75	3.00	2.25	1.75	1.50																				
	2.0	4.50	4.50	4.50	4.50	3.00	1.50	0.50																							
900	0.5	4.50	4.50	4.50	4.50	4.50	4.50	3.50	3.00	2.50	2.00																				
	1.0	4.50	4.50	4.50	4.50	4.50	3.75	3.00	2.25	1.75	1.50																				
	2.0	4.50	4.50	4.50	4.50	3.00	1.75	0.75																							
1000	0.5	4.50	4.50	4.50	4.50	4.50	4.50	3.50	3.00	2.50	2.00																				
	1.0	4.50	4.50	4.50	4.50	4.50	3.75	3.00	2.25	2.00	1.50																				
	2.0	4.50	4.50	4.50	4.50	3.25	1.75	0.75																							
1100	0.5	4.50	4.50	4.50	4.50	4.50	4.50	3.50	3.00	2.50	2.00																				
	1.0	4.50	4.50	4.50	4.50	4.50	3.75	3.00	2.25	2.00	1.50																				
	2.0	4.50	4.50	4.50	4.50	3.25	1.75	0.75																							
1200	0.5	4.50	4.50	4.50	4.50	4.50	4.50	3.50	3.00	2.50	2.00																				
	1.0	4.50	4.50	4.50	4.50	4.50	3.75	3.00	2.25	2.00	1.50																				
	2.0	4.50	4.50	4.50	4.50	3.25	1.75	0.75	0.25																						

Table 18.2: Maximum permissible wind load for different glass configurations.









