



Engineering progress
Enhancing lives

RAUTITAN water, fire sprinkler and gas

Technical Information.



REHAU

Contents

RAUTITAN - WATER AND GAS

General Guidelines	5
Pipes, fittings and tools	9
Planning and installation (water and gas)	21
Water application	45
Fire sprinkler	55
Gas application	59
Certificates and standards	71
Appendices	74

RAUTITAN water and gas



This Technical Information **RAUTITAN - Water and Gas** is valid from **January 2020**.

This publication means that the previous Technical Information are no longer valid.

The latest version of this Technical Information can be found at www.rehau.com.au/RAUTITAN or www.rehau.co.nz/RAUTITAN for download.

This documentation is copyright protected. The rights of translation, reproduction, drawing of illustrations, broadcasting, and rendering on photomechanical or by similar means as well as the storage in data processing systems, are reserved.

All measurements and weights are of approximate values. Errors and changes are to be expected.

Contents

1	Information and safety advice	5	7.6	Provision for thermal expansion	33	10	Specific guidelines for fire sprinkler application	56
2	Component overview	8	7.6.1	Calculating thermal length changes	33	10.1	Validity	56
3	Pipes and fittings	9	7.6.2	Deflection legs	34	10.2	Standards and guidelines	56
3.1	PE-X materials	9	7.6.3	Calculation of deflection leg length	35	10.3	RAUTITAN components and tools	56
3.2	Technical data of pipes	9	7.6.4	Calculation examples	35	10.4	Installation and operation	56
3.3	RAUTITAN compression sleeves	11	7.7	Installing threaded fittings	36	10.4.1	Operating parameters	56
3.4	RAUTITAN fittings	11	7.8	Transition to other pipe materials	36	10.4.2	System identification	56
4	Installation tools: Rautool	14	7.8.1	Transition to copper system	37	10.5	Pressure testing and commissioning	59
4.1	Compression sleeve tools: Rautool	15	7.8.2	Transition to stainless steel system	37	10.5.1	Commissioning procedure	59
4.1.1	RAUTOOL L1	15	7.8.3	Connection to fittings	38	10	Specific guidelines for gas application	60
4.1.2	RAUTOOL A3	15	7.9	Reusing jointing components	38	11.1	RAUTITAN gas connection	60
4.1.3	RAUTOOL A-Light2	15	7.9.1	Reusable components	38		components and tools	60
4.1.4	RAUTOOL G2	15	7.9.2	Reusing RAUTITAN MX fittings	39	11.2	Standards and guidelines	62
4.2	Pipe cutters	16	7.10	Installation within concrete/screed floors and walls	40	11.3	Operating parameters	62
4.2.1	Pipe cutter 16/20 stabil	17	7.11	Installation in areas exposed to UV radiation and light	40	11.4	System accessories	62
4.2.2	Pipe cutter 25	17	7.12	External installation above ground	40	11.4.1	RAUGUARD protective conduit	62
4.2.3	Pipe cutter 40	17	7.13	Installation below ground	41	11.4.2	Protective conduit (PE)	62
4.2.4	Pipe cutter 63	17	7.14	Installation beneath a concrete slab	41	11.5	Installation of RAUTITAN gas system	63
4.3	Expanding tools	18	7.15	Exposure to excessive heat	42	11.5.1	REHAU Authorised Installer	63
4.3.1	Expander heads and expander bits for pipes	18	7.16	Aligning fittings	42	11.5.2	Gas installation requirements	63
4.3.2	Expander heads QC	18	7.17	Heat trace	42	11.5.3	Prohibited locations	65
4.3.3	Expander set 16/20	18	7.18	Potential equalization	42	11.6	Pressure testing RAUTITAN gas system	65
4.3.4	Expander bits	18	7.19	Installation in combination with bitumen sheets and coatings	43	12	Sizing RAUTITAN gas system	66
4.4	Notes on the compression jaws size 40	20	7.20	Installation in areas with asphalt screed	43	12.1	General	66
5	Transport and storage	21	8	Fire safety	44	12.2	Pipe sizing method	66
6	Making the compression sleeve joint	22	9	Specific guidelines for water application	46	12.3	Working example	67
6.1	Jointing procedure	22	9.1	Standards and guidelines	46	13	Certificates and standards	71
6.1.1	Cutting the pipe	22	9.2	Operating parameters	46	13.1	Certificates for Australia and New Zealand	71
6.1.2	Sliding the compression sleeve onto the pipe	23	9.3	Drinking water requirements	46	13.2	Standards, regulations and guidelines	72
6.1.3	Expanding the pipe	24	9.4	Disinfection of water services	46	APPENDICES	74	
6.1.4	Inserting the fitting into the expanded pipe	24	9.4.1	Thermal disinfection in case of contamination	47	Appendix A1 - Application of corrosion protection system for fittings installed below ground	75	
6.1.5	Compressing the joint	25	9.4.2	Chemical disinfection in the case of contamination	47	Appendix A2 - RAUGUARD protective conduit installation	77	
7	Installation guidelines - water and gas	26	9.4.3	Chemical "postrinse disinfection"	47	Appendix A3 - Pressure drop tables RAUTITAN gas stabil (Natural gas)	84	
7.1	General	26	9.4.4	Continuous chemical disinfection	48	Appendix A4 - Pressure drop tables RAUTITAN gas stabil (LPG)	87	
7.2	Protection against corrosion and damage	26	9.5	Thermal insulation	49	Appendix A5 - RAUTITAN gas fitting - Equivalent pipe lengths	88	
7.3	Pipe support and fixing	28	9.6	Noise reduction	49	Appendix A6 - Form: Pressure test for gas application	89	
7.3.1	Pipe brackets and clips	28	9.7	Water heater connection	50	Appendix A7 - Form: Pressure test for water application (Test medium: water)	90	
7.3.2	Anchor points	28	9.7.1	Storage water heaters	50	Appendix A8 - Form: Pressure test for water application (Test medium: air)	91	
7.3.3	Spacing between brackets and clips	28	9.7.2	Instantaneous water heater	50			
7.3.4	Exposed installation	28	9.7.3	Water heaters with uncontrolled energy sources	50			
7.4	Pipe support channel	30	9.7.4	Solar water heaters	50			
7.4.1	Benefits of using pipe support channel	30	9.8	Rain water application	51			
7.4.2	Functionality	30	9.9	Recycled water application	51			
7.4.3	Assembly of the pipe support channel	30	9.10	Water services flushing and pressure test	52			
7.5	Pipe bending	32	9.10.1	Flushing and pressure test	52			
7.5.1	Bending RAUTITAN stabil and RAUTITAN gas stabil	32	9.10.2	REHAU Pressure test with water	52			
7.5.2	Bending RAUTITAN platinum, RAUTITAN red, RAUTITAN green and RAUTITAN lilac	32	9.10.3	REHAU Pressure test with air	53			
			9.10.4	Purging and commissioning	54			

01 Information and safety advice

Notes on this Technical Information

Validity

This Technical Information is valid for Australia and New Zealand.

Navigation

At the beginning of this document you can find a detailed content page which lists the individual chapters and their respective page numbers.

Definitions

- **Supply lines or piping** consist of pipes and their joints (e.g. compression sleeves, fittings, threads, or similar). This applies to gas piping, drinking water and heating piping and all other pipes in this Technical Information.
- **Piping systems, installations, systems**, etc. consist of the pipes and the necessary components.
- **Connection components** consist of fittings with the corresponding compression sleeves and pipes as well as seals and screw connections.

Illustration

Illustrations for individual subsystems are listed in the corresponding pipe, fitting and compression sleeve colours. Illustrations, which are applicable for system-wide applications, such as drinking water, heating, and gas installation or underfloor heating/cooling are illustrated with grey piping and white fittings/compression sleeves.

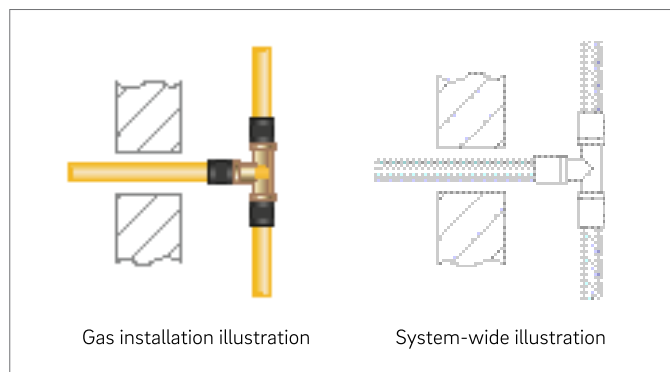

Example: Illustration for gas installation sub-system (left) and System-wide illustration for multiple sub-systems (right)

RAUTITAN gas system components

This Technical Information describes the components and requirements for the installation of RAUTITAN gas system using RAUTITAN ONE fittings and RAUTITAN PX polymer sleeves.

Explanation of symbols



Safety information



Legal information



Important information, which needs to be taken into account



Information on the Internet



Your benefits/advantages



Updated Technical Information

For your own safety and the correct use of our products, check regularly whether the Technical Information which you have is available in a latest version.

The date of issue of your Technical Information is always printed on the bottom left of the cover.

The latest Technical Information can be found at your REHAU sales office, specialist wholesaler or online for download at www.rehau.com.au or www.rehau.co.nz.

Safety advice and operating instructions

- Please read these safety instructions and technical information carefully and completely for your own safety and other's before beginning the installations.
- Please keep this copy for your future reference.
- If you have any questions or need further clarifications on the safety instructions and/or the individual installation instructions, please contact your nearest REHAU sales office.
- **Failure to observe the safety information/instructions can result in damage to property and persons.**

Intended use

The REHAU system components and compression sleeve jointing technique is considered as propriety systems and should be designed, installed, and operated in accordance to REHAU's Technical Information. Any other use that does not fall within the intended use of the system is prohibited.

Piping network calculation

In addition to the information contained in this technical document various services are offered for the sizing of drinking water and heating systems by REHAU.

For extensive advice, please consult your REHAU sales office.



When installing this pipe system, please observe all applicable national and international regulations on installation, accident prevention and safety together with the information contained in this Manual.

Also observe the applicable laws, standards, guidelines and regulations (e.g. DIN, EN, ISO, NCC, BCA, PCS, NZBC, AS/NZS) as well as regulations on environmental protection, provisions of professional associations and regulations of the local public utility companies.

Any applications not described in this Manual - i.e. non-standard applications - must be discussed with our Technical Applications Department. For more detailed advice, please contact your REHAU Sales Office.

This design and installation information is related solely to the specific REHAU product. Occasionally, references are made to parts of applicable standards and directives. Always observe the current version of any guidelines, standards or directives.

Further standards, directives and guidelines related to the design, installation and operation of drinking water, heating or buildings services systems should also be referred to, but these do not form part of this Technical Information.



General safety measures

- Keep your workplace tidy and free of obstructions.
- Ensure there is always sufficient light.
- Keep children, pets and unauthorised persons away from tools and installation areas. This is especially important when carrying out refurbishment/repair work in occupied areas.
- Only use the corresponding components in the piping system that have been generally approved by REHAU. Using components which are not part of the system or tools which do not originate from the respective REHAU installation system can lead to accidents or other hazards.

Fire protection

Pay particular attention to the applicable fire protection regulations and the correspondingly valid building regulations/regional building regulations/ building codes, especially when:

- penetrating through ceilings and walls
- working in areas with specific requirements of preventative fire protection measures (observe national regulations)

Trades qualifications

- Only authorised and trained persons are allowed to install REHAU systems.
- Work on electrical systems and cables shall only be carried out by qualified, competent and authorised specialists.

Work clothing

- Wear eye protection, adequate work clothing, protective shoes, safety helmets, and a hairnet if you have long hair.
- Do not wear loose clothing or jewelry as these can be caught by moving parts.
- A safety helmet must be worn especially when carrying out installation work at face level or overhead.

Follow the installation instructions

- Read carefully and observe at all times the Operating Manual for the REHAU installation tool which is being used.
- Incorrect handling of tools can cause cuts, crush or sever limbs.
- Incorrect handling of tools can damage jointing components and cause leaks.
- The REHAU pipe cutters have a sharp blade. Store and handle them in such a way that the REHAU pipe cutters will not create any risk of injury.
- When cutting the pipe to the desired length, keep a safe distance between the holding hand and the tool (pipe cutter).
- When cutting, do not reach into the cutting zone of the tool or near its moving parts.
- After the pipe expansion process, the expanded end of the pipe will return to its original shape (due to memory effect). During this time, do not put any other objects into the end of the expanded pipe, except for the intended REHAU fitting.
- Keep your hands away from movable parts or the tools pressing area during jointing.
- Before the joint is completed, the fitting may fall out of the pipe. This is an injury hazard.
- Always disconnect the power from a tool prior to carrying out maintenance work. This may include changing over any moveable parts (eg. compression jaws) or when moving the tool to a new location on site.

Operating parameters

- If the operating parameters are exceeded, the pipes and joints may become overstrained. Not adhering to the operating parameters is thus not allowable.
- Keeping within the operating parameters must be ensured by safety control equipment (e.g. pressure reducers, safety valves, etc.)



Gas piping: General safety measures

- Failure to observe the safety information/instructions may cause explosions and fire and can result in fatal damage to persons.
- Always observe the requirements of the national gas standards, e.g. AS/NZS 5601.1.
- Take extra care when designing and installing gas installations.
- Ensure through appropriate safety measures that there is no possibility of uncontrolled gas leaks.
- Installation, modification and maintenance work on gas consumer piping may only be carried out by the following persons:
 - gas utility person
 - gas fitters with a valid gas fitters license for the installation location area.
- Always coordinate any work on gas installations with the responsible gas provider prior to commencing the work.
- When working on gas consumer piping, escape routes must be kept free at all times to ensure a quick and safe escape. Emergency exits are to be kept clear.

Gas piping: What to do if there is a smell of gas in buildings

- Open all doors and windows to create a breeze path, avoid rooms which smell of gas.
- Avoid any sparks or open flames / fires – if one is present extinguish it, do not smoke and do not use any lighters.
- Do not operate any electrical switches, plugs, door bells, phones and other communication devices in the building.
- Close the main lead and the isolating valve at the gas meter that lead into the building.
- Warn other occupants of the building, but do not use the door bells and leave the building.
- Contact the service centre of the gas provider/utility from a phone outside the building.
- If you can hear leaking gas, leave the building immediately. Prevent anyone else from entering the building. Call the police and fire brigade from outside of the building!
- If the gas smell originates from a non-accessible room, contact the police and fire brigade immediately from outside of the building!

Gas piping: What to do in case of fire

- Call the fire brigade.
- Do not extinguish burning gas, as unburnt gas can pose an explosion risk.
- Close isolating valve at gas meter and/or main that leads into the building if it can be done without any danger.

Gas piping: Additional information















We recommend observing the following points, in addition to the safety requirements and accident prevention measures which are in force in your area:

- Do not smoke during work on gas installations and remove any other potential ignition sources.
- Prior to starting the work, close the respective isolating valves and secure them against unauthorised opening, e.g. by removing the handle or key.
- Ensure all inlets and outlets of gas pipes are closed and gas-tight, e.g. using end stops or plugs, if there is a possibility the isolating valve could be opened unauthorised, intentionally or accidentally or if you have to leave the workplace only for a short time.
- Ensure that all isolating valves are actually closed in a gas-tight manner.
- Once the pipe section you work on has been isolated correctly, the gas inside the pipe has to be vented out. The venting out of the gas has to be done in a safe manner using hoses.
- Pipe sections that are out-of-order or no longer in use or disconnected must be sealed permanently at their inlets and outlets in a gas-tight manner, e.g. by using plugs stoppers, end caps or blank flanges.
- Immediately seal all openings resulting from the dismantling of gas meters.
- Prior to cleaning the gas consumer piping, remove all gas appliances, pressure regulators, gas meters and fixtures. Clean the pipes by blowing out the pipes strictly to the outside of the building!
- If possible use gas detection devices for locating gas leaks. Never, under any circumstances, use a naked flame to search for a gas leak.
- In case of using foaming chemicals to locate leaks, be aware that hemp used for sealing joints can temporarily swell and prevent leakage detection.
- Upon completing the pipework installation, always carry out a test for gas leaks. For this test, the gas pipes must not be covered by anything. All joints must be free from any \ coats and the gas pipes must not be connected to any pipes carrying gas.
- Prior to putting the pipework back into operation, fill the pipes with the intended operating gas and purge out the air inside the pipes until all the air inside the pipes has been fully replaced by the gas. The exiting air/gas mix has to be safely discharged to the outside of the building.
- Prior to putting the complete gas installation into operation, make sure a pressure test is carried out successfully in accordance with rules and regulations currently in force and a pressure test protocol is completed.
- When putting a gas system into operation and the system is charged with gas, ensure all pipe openings are gas-tight.

02 Component overview

RAUTITAN

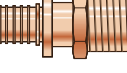
RAUTITAN universal system for drinking water and heating

	Size 16 – 25	Size 32 - 40	Size 50 – 63
Pipe	 Hot and cold water pipe RAUTITAN platinum		
	 Rainwater pipe RAUTITAN green		
	 Recycled water pipe RAUTITAN lilac		
	 Hot water pipe RAUTITAN red		
	 Water and Heating pipe RAUTITAN stabil		
	 Gas pipe RAUTITAN gas stabil		
Compression sleeve	 RAUTITAN PX PVDF		 RAUTITAN MX Brass
Fittings for water	 RAUTITAN PX PPSU		 RAUTITAN MX Dezincification-resistant special brass
	 RAUTITAN PXsr PVDF	 RAUTITAN MX Dezincification-resistant special brass	
	 RAUTITAN MX Dezincification-resistant special brass		
	 RAUTITAN RX+ Low-lead gunmetal, lead content <=0.1%		
Universal fittings for water and gas	 RAUTITAN ONE DZR Brass with yellow marking		
RAUTOOLS	Manual and battery operated compression tools, expanding tools and pipe cutters. Refer to Chapter 4.		

03 Pipes and fittings

3.1 PE-X materials

- ✓ - Corrosion resistance of the pipes: No pitting
- No tendency to deposits
- Polymer pipe material reduces sound transmission along the pipe
- Good resistance to abrasion
- All RAUTITAN pipes with WaterMark registration comply with AS/NZS 4020 (hygienic requirements)

Peroxide-crosslinked polyethylene

Peroxide-crosslinked polyethylene is designated PE-Xa. This method of crosslinking is conducted at high temperature and pressure with the aid of peroxides. Here, the individual molecules of the polyethylene combine to form a three-dimensional network. This high-pressure crosslinking is characterised by crosslinking in the melt away from the crystallite melting point. Crosslinking occurs during the moulding of the pipe in the tool. This method of crosslinking ensures an even and very high degree of crosslinking over the entire cross-section of even thick-walled pipes.

Inliner of RAUTITAN stabil and RAUTITAN gas stabil pipe

The interior pipe in RAUTITAN stabil and RAUTITAN gas stabil pipe, which comes into contact with the flowing medium, is known as inliner. This inliner is made of cross-linked polyethylene (PE-X).

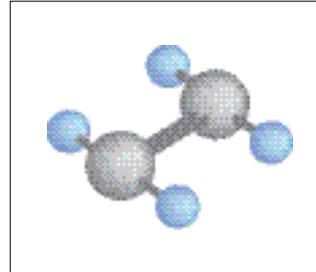

Fig 3 -1 Ethylene

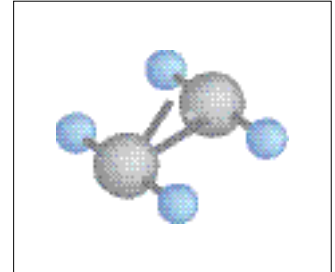

Fig 3 - 2 Ethylene, detaching double bond

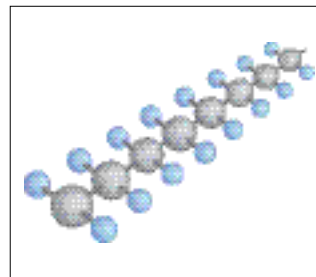

Fig 3 - 3 Polyethylene (PE)

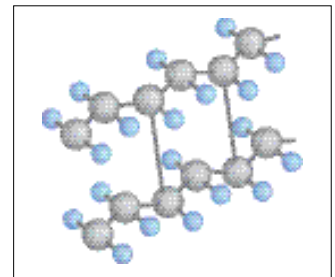







Fig 3 - 4 Crosslinked polyethylene (PE-X)

3.2 Technical data of pipes

Water and Heating pipe stabil	Pipe dimensions				
	16	20	25	32	40
Volume (l/m)	0.095	0.158	0.243	0.401	0.616
Pipe weight, empty (kg/m)	0.135	0.185	0.290	0.466	0.734

Hot and cold water pipe platinum	Pipe dimensions							
	16	20	25	32	40	50	63	
Hot water pipe red								
Rainwater pipe green								
Recycled water pipe lilac								
Volume (l/m)	0.106	0.163	0.254	0.423	0.661	1.029	1.647	
Pipe weight, empty (kg/m)	0.097	0.152	0.233	0.374	0.583	0.913	1.458	

Tab 3 - 1 Pipe volume and weight

Technical data		Pipes					
	Unit	Hot and cold water pipe 	Hot water pipe 	Rainwater pipe 	Recycled water pipe 	Water and heating pipe 	Gas pipe 
		PE-Xa Platinum	PE-Xa Dark red	PE-Xa Green	PE-Xa Lilac	PE-X/AL/PE Silver	PE-X/AL/PE Yellow
Surface colour	-	Platinum	Dark red	Green	Lilac	Silver	Yellow
Operating pressure (maximum)	[bar] [kPa]	10 1000	10 1000	10 1000	10 1000	10 1000	0.7 70
Operating pressure (ISO 15875 classes 1,2)	[°C]	70	70	70	70	70	60
- Continuous		-	-	-	-	-	-
- Minimum		95	95	95	95	95	90
Short-term maximum temperature (malfunction)	[°C]	+50 / -10	+50 / -10	+50 / -10	+50 / -10	+50 / -10	+50 / -10
Maximum/minimum laying temperature	[°C]	-	-	-	-	Oxygen-tight	Oxygen-tight
Oxygen diffusion (to DIN 4726)	-	B2	B2	B2	B2	B2	B2
Building material class acc. EN 13501-1	-	E	E	E	E	E	E
Construction product class acc. EN 13501-1	-						
Thermal conductivity	[W/(mK)]	0.35	0.35	0.35	0.35	0.43	0.43
Pipe roughness	[mm]	0.007	0.007	0.007	0.007	0.007	0.007
Available sizes	[mm]	16 x 2.2 20 x 2.8 25 x 3.5 32 x 4.4 40 x 5.5 50 x 6.9 63 x 8.6	16 x 2.2 20 x 2.8 25 x 3.5	16 x 2.2 20 x 2.8 25 x 3.5 32 x 4.4 40 x 5.5 50 x 6.9 63 x 8.6	16 x 2.2 20 x 2.8 25 x 3.5 32 x 4.4 40 x 5.5 50 x 6.9 63 x 8.6	16 x 2.6 20 x 2.9 25 x 3.7 32 x 4.7 40 x 6.0	16 x 2.6 20 x 2.9 25 x 3.7 32 x 4.7 40 x 6.0
RAUTITAN system appraisals and certificates		WaterMark (LN 1412, LN 1413); BRANZ 434 to AS 2492, AS/NZS 2537, AS/NZS 4020, ISO 15875 Class 1-5 / 10 bar (further compliance certificates available on request)				WaterMark (LN 21210); BRANZ 434 to AS 4176, AS/NZS 4020	

Tab. 3- 2 Technical data of pipes (approximate values)



Pipes can be subjected to maximum operating temperature or maximum operating pressure and not both.



Single cases of blistering on the pipe surface of RAUTITAN stabil pipes may occur during operation. This blistering does not represent any reduction in quality or in usability and is not critical.



RAUTITAN gas stabil pipe may only be used in consumer gas installation in accordance with AS/NZS 5601.1

3.3 RAUTITAN compression sleeves



Compression sleeves for RAUTITAN water and gas services and heating installation



Fig. 3-5 RAUTITAN PX compression sleeve

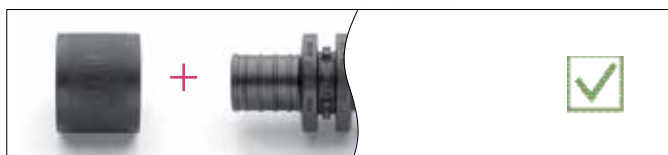

Fig. 3-6 RAUTITAN MX compression sleeve

Sleeve		
Designation	RAUTITAN PX	RAUTITAN MX
Application	Water Gas	Water
Size	16 20 25 32 40	50 63
Material	PVDF	Thermally annealed brass
Colour	Black	Brass
Characteristics	Identical ends	One end chamfered, one end flat

Tab. 3-3 RAUTITAN compression sleeves

- Compression sleeve jointing technique with permanent sealing
- According to EN 806, DIN 1988 and DVGW worksheet W 534
- Approved for flush-mounted installation according to DIN 18380 (VOB)



3.4 RAUTITAN fittings



Fig. 3-7 Fittings RAUTITAN PXsr made of PVDF







Fig. 3-8 Fittings RAUTITAN MX (DZR brass) and RAUTITAN ONE (DZR brass with yellow marking)



- All fittings and compression sleeves RAUTITAN PX/ PXsr, RAUTITAN MX, RAUTITAN ONE and RAUTITAN RX+/EX+ can be used for water services.
- RAUTITAN ONE fitting (with yellow marking) and RAUTITAN PX compression sleeves can be used for gas installations.
- Use RAUTITAN PX or PXsr fittings only in combination with RAUTITAN PX compression sleeves.
- Do not combine fittings and compression sleeves from different ranges with each other.
- Please note the dimensions of the fittings and compression sleeves.
- You can find the range of connection components in the latest product book.

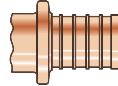
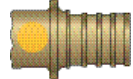

- Compression sleeve jointing technique with permanent sealing in accordance with EN 806, DIN 1988 and DVGW-worksheet W 534
- Robust jointing technique, highly suitable for construction site
- Without o-ring (self-sealing pipe material)
- Easy visual inspection
- Can be pressurised immediately
- Minimised pressure loss in fittings
- RAUTITAN MX and RAUTITAN ONE fittings are made of special dezincification-resistant brass according to AS 2345, EN 12164, EN 12165 and EN 12168

Fitting						
						
Designation	RAUTITAN PXsr	RAUTITAN PX	RAUTITAN MX	RAUTITAN EX+	RAUTITAN RX+	RAUTITAN ONE
Application	Water	Water	Water	Water (low lead)	Water (low lead)	Water Gas
Size	16	16	16	16	16	16
	20	20	20	20	20	20
		25	25		25	25
		32	32		32 (NZ only)	32
		40	40		40 (NZ only)	40
			50			
			63			
Material	PVDF (lead content 0%)	PPSU (lead content 0%)	DZR Brass	Low lead DZR Brass, lead content <=0.1%	Low-lead gunmetal, lead content <=0.1%	DZR Brass
Colour	Black	Black	Brass	Brass marking EX+	Red brass, marking Rg+	DZR Brass with yellow marking
Connection Type	- Threadless	- Threadless	- Screwing - Brazing - Compressing	- Screwing - Compressing	- Threadless - Screwing - Compressing	- Threadless - Screwing - Brazing - Compressing

Tab. 3-4 RAUTITAN fittings

Material

- **RAUTITAN PXsr:** PVDF
- **RAUTITAN PX:** PPSU
- **RAUTITAN MX:** Special dezincification-resistant brass according to AS 2345, EN 12164, EN 12165 and EN 12168 standards
- **RAUTITAN ONE:** Same material and properties as RAUTITAN MX, in addition marked with a yellow dot which are suitable for water and gas services.
- **RAUTITAN RX+:** gunmetal with a low lead content of <= 0.1%.
- **RAUTITAN EX+:** Dezincification-resistant Ecobrass CW724R with a low lead content of <=0.1%.
- **Dezincification resistance**
Under the effects of certain types of drinking water, a particular form of corrosion known as dezincification can occur in standard brass alloys, e.g. free-cutting brass.
- RAUTITAN MX fittings used in water services and heating installation are made of special dezincification-resistant brass and are tested for drinking water installation according to ISO 6509 and AS 2345. Fittings made of this special dezincification-resistant DZR brass have been proven in practice and have been in use for decades.
- RAUTITAN RX+ fittings are made of especially corrosion resistant gunmetal.

Erosion/Erosion corrosion

- Erosion is the pitting of materials beginning at the surface, caused by extreme velocities.

- RAUTITAN pipes for water services and heating installation are expanded before jointing. The flow cross-section of the pipe is therefore adjusted to that of the fitting. This hydraulic and corrosion resistance advantage is optimised in RAUTITAN systems for water services and heating installation, in contrast to systems in which the pipes are not expanded at the joint.



Use RAUTITAN PX and PXsr fittings only in combination with RAUTITAN PX compression sleeves. Do not use RAUTITAN PXsr fittings made of PVDF in combination with RAUTITAN stabil pipe.

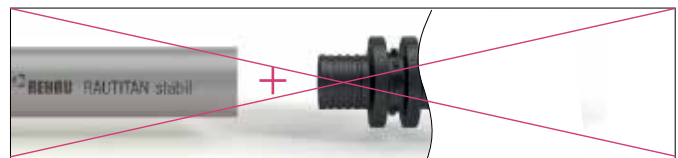
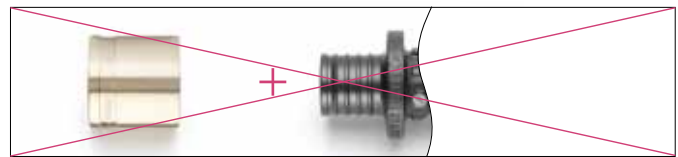

Fittings suitable for gas installation

- Only use RAUTITAN ONE fittings in gas installation. These are made of DZR brass and identified with a yellow marking.
- Do not use RAUTITAN PX, PXsr, MX, RX+, EX+ fittings for gas installation.
- The range of the connection components can be found in the latest product book.

Fittings suitable for RAUTITAN stabil pipe 16-32m

stabil

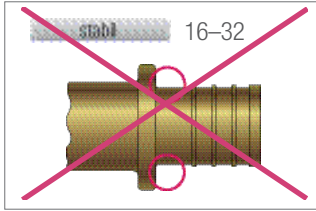

Fig. 3-10 Brass fitting without pre-stop, size 16-32

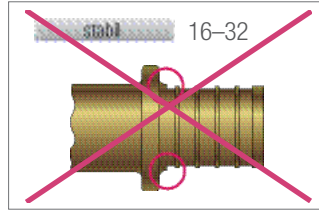

Fig. 3-11 Brass fitting with partially shaped pre-stop, size 16-32

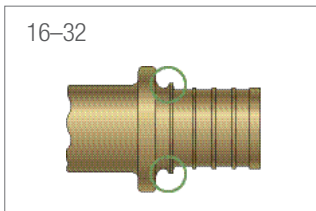

Fig. 3-12 Fitting with fully shaped pre-stop, size 16-32



Don't use RAUTITAN MX brass fittings without fully shaped pre-stop in combination with RAUTITAN stabil pipes.

Since 1997, production at REHAU has been changed completely to incorporate fitting contours with pre-stop in sizes 16-32.

For detailed information about the compatibility of the fittings and compression sleeves with existing pipes, please contact your REHAU sales office.

04 Installation tools: RAUTOOL



RAUTOOL installation tools are specially designed and manufactured to work with REHAU programs.
Manual and battery operated tools available
Flexible and good tool handling
No pipe calibration required



Before using tools, read and observe the information in the operating instructions completely.
If these operating instructions are no longer present with the tool or are not longer available, order a copy or download them from the internet.
Do not use damaged tools or partially functioning tools; send these for repair to your REHAU sales office.



Operating instructions can be downloaded online from **www.rehau.com.au** or **www.rehau.co.nz**.

4.1 Compression sleeve tools: RAUTOOL

For RAUTITAN system
 For REHAU underfloor heating/cooling
 For special ranges, e.g. RAUTHERMEX for district heating
 Various attachment sets and accessories (see product book)

4.1.1 RAUTOOL L1



Fig. 4-1 RAUTOOL L1

- Manual tool
- Sizes 16–25



Only use compression jaws L1 that are specifically approved for PX with RAUTITAN PX polymer sleeves

4.1.2 RAUTOOLA3



Fig. 4-2 RAUTOOLA3

- Battery-operated hydraulic tool
- Sizes 16–40
- Drive with battery-operated hydraulic unit located directly at the tool cylinder
- The tool cylinder can be used optionally for hydraulic expansion.

4.1.3 RAUTOOLA-light2



Fig. 4-3 RAUTOOLA-light2

- Battery-operated hydraulic tool
- Sizes 16–40
- Drive with battery-operated hydraulic unit located directly at the tool cylinder
- The tool cylinder can be used optionally for hydraulic expansion.



The RAUTOOL A2/A3/A-light/A-light2 are compatible with each other and can be equipped with the same supplementary sets.

4.1.4 RAUTOOL G2







Fig. 4-4 RAUTOOL G2

- Tool for the pipe sizes 50–63 (optionally available for size 40 x 5.5)
- Drive with electro-hydraulic power unit (optionally with a foot pump)
- The tool cylinder can be used optionally for expansion and clamping.





4.2 Pipe cutters

When cutting RAUTITAN pipes, observe the following:

- Use the correct pipe cutters for the corresponding pipe type only.
- Cut the pipe square and without burrs.
- Pipe cutters must be in good working condition.
Spare blades for pipe cutters can be re-ordered (except for pipe cutter 25)

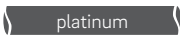
Water and Heating pipe		Pipe dimensions				
		16	20	25	32	40
Gas pipe						
Pipe cutters:						
Pipe cutter 16/20 (stabil)		+	+	-	-	-
Pipe cutter 25		-	-	-	-	-
Pipe cutter 40		-	-	+	+	+

Tab. 4-1 Pipe cutters for RAUTITAN stabil and RAUTITAN gas stabil pipes

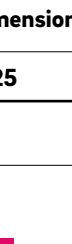
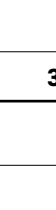
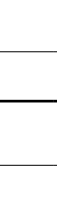
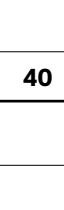
Hot and cold water pipe		Pipe dimensions						
		16	20	25	32	40	50	63
Hot water pipe								
Rainwater pipe								
Recycled water pipe								
Pipe cutters:								
Pipe cutter 16/20 (stabil)		+	+	-	-	-	-	-
Pipe cutter 25		+	+	+	-	-	-	-
Pipe cutter 40		+	+	+	+	+	-	-
Pipe cutter 63		-	-	-	-	+	+	+

Tab. 4-2 Pipe cutters for RAUTITAN PE-Xa pipes

4.2.1 Pipe cutter 16/20 (stabil)



Fig. 4-5 Pipe cutter 16/20 (stabil) required for cutting RAUTITAN stabil pipe

For right-angled cutting and without burrs of RAUTITAN stabil pipe in sizes 16 and 20.



Only use pipe cutter 16/20 (stabil) when cutting RAUTITAN stabil and RAUTITAN gas stabil pipe sizes 16 and 20.



PE-X pipes can also be cut with the pipe cutter 16/20 (stabil).



Fig. 4-6 Calibrating mandrel



When using the compression nut set, calibrate RAUTITAN stabil pipe (sizes 16 and 20) using the calibrating mandrel which is moulded onto the side of the pipe cutters 16/20 (stabil).

4.2.2 Pipe cutter 25



Fig. 4-7 Pipe cutter 25

To be used exclusively for burr-free cutting of PE-X pipes up to size 25 (see Tab. 4-1 and 4-2).

4.2.3 Pipe cutter 40



Fig. 4-8 Pipe cutter 40

To be used exclusively for burr-free cutting of PE-X-pipes up to size 40 and for RAUTITAN stabil/RAUTITAN gas stabil in size 25 to size 40 (see Tab. 4-1 and 4-2).

4.2.4 Pipe cutter 63



Fig. 4-9 Pipe cutter 63

To be used exclusively for burr-free cutting of RAUTITAN pipes or PE-X-pipes sizes 40–63 (see Tab. 4-1 and 4-2).

4.3 Expanding tools

4.3.1 Expander heads and expander bits for pipes

Take care when using expander tools:

- Use only undamaged tools in good working condition
- Make sure the correct expander head is used with its respective pipe type
- Keep the sleeve outside the expansion area to avoid damage to the pipe or the expansion segments
- Don't drop expander heads as segments may bend or break
- Avoid rust and corrosion. Keep heads and tools dry and regularly lubricate the expander tool cone with REHAU lubricant included in the tool case. Worn or corroded expander heads shall be replaced.

4.3.2 Expander heads QC

The Expander heads QC (Quick Change) include a quarter-turn locking mechanism for easy tool change. They adapt to the Expander tool QC (in black colour). The Expander tool QC can accommodate both, the Expander heads QC as well as Expander heads RO with screw connection.

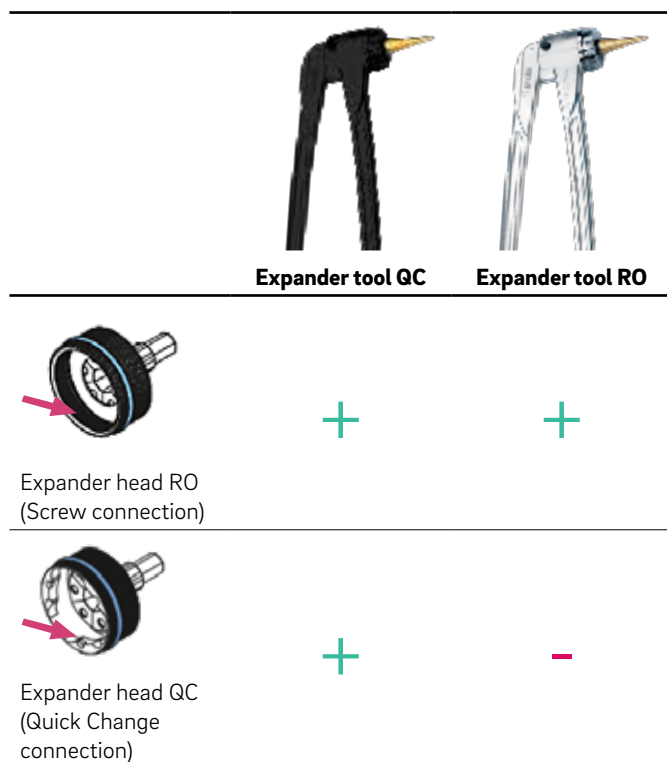

4.3.3 Dual expander bit 16/20

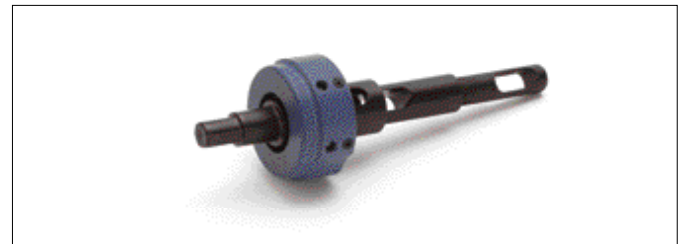

Fig. 4-10 Dual expander bit 16/20

The Dual expander bit 16/20 can be used in combination with RAUTOOL A2/A3/A-light/A-light2 to expand RAUTITAN platinum, RAUTITAN red, RAUTITAN pink, RAUTITAN green, RAUTITAN lilac and RAUTHERM S 16 x 2.0 mm.

Differences between expander heads

Expander head for RAUTITAN stabil and RAUTITAN gas stabil pipes:

- Green colour code
 - Black retaining nuts for sizes 16–32
 - Expansion segments with tapered ends
- Expander head for RAUTITAN platinum, RAUTITAN red, RAUTITAN green, RAUTITAN lilac and RAUTHERM S 16 x 2.0mm
- Blue colour code
 - Silver retaining nut for sizes 16-32
 - Expansion segments are not tapered

4.3.4 Expander bits





Fig. 4-11 Expander bits



The following expander bits can be used in combination with RAUTOOL A2, A3, A-light and A-light2:

- Universal expander bit 25/32 system RO
- Expander bit 40 x 6.0 stabil (for RAUTITAN stabil and RAUTITAN gas stabil pipes)
- Expander bit 40 x 5.5 (for RAUTITAN PE-Xa pipes)

RAUTITAN stabil and RAUTITAN gas stabil pipes size 40 can only be expanded using the expander bit 40x6.0 (green) in combination with RAUTOOL A2, A3, A-light or A-light2. Expansion is not possible with RAUTOOL G1/G2 and M1.

Water and Heating pipe	stabil	Pipe dimensions					19
		16	20	25	32	40	
Gas pipe	gas stabil						
Expander heads and expander bits:							
Expander head with green rings and tapered end		+	+	+	+	-	
Expander bit 40 (green) with tapered end		-	-	-	-	+	

Tab. 4-3 Expander heads for RAUTITAN stabil and RAUTITAN gas stabil pipes















Hot and cold water pipe	platinum	Pipe dimensions						
		16	20	25	32	40	50	63
Hot water pipe	red							
Rainwater pipe	green							
Recycled water pipe	lilac							
Expander heads and expander bits:								
Dual expander head 16/20 black with blue ring*		+	+	-	-	-	-	-
Dual expander bit 16/20 (blue)		+	+	-	-	-	-	-
Single expander head with blue rings		+	+	+	+	-	-	-
Expander bit 40 (blue)		-	-	-	-	+	-	-
RAUTOOL G2 Expander head		-	-	-	-	+	+	+

Tab. 4-4 Expander heads for RAUTITAN PE-Xa pipes



*Notes on dual expander head 16/20. A new dual expander head with black retainer nut and blue-coloured ring replaces the old silver dual expander head. The old dual expander head shall not be used to expand RAUTITAN PE-Xa pipes.

4.4 Notes on the compression jaws size 40

Compression jaws for RAUTITAN PX compression sleeves, size 40			
Compression jaws, new Ø 40	Compression sleeves Ø 40	Compression jaws, old Ø 40	Compression sleeve RAUTITAN PX Ø 40
Compression jaws set 40 (Black) 201801-001 201803-001 	 + 	 Compression jaws set 40 (Gold-yellow) 137805-001 138223-001  	 + 
Compression jaws set M1 40 (Black) 201798-001 201804-001 	 + 	 Compression jaws set M1 40 (Gold-yellow) 137374-001 138333-001  	 + 
Compression jaws set G1/G2 40 (Black) 201802-001 	 + 	 Compression jaws set G1/G2 40 (Gold-yellow) 137964-001  	 + 

Tab. 4-5 Compression jaws for RAUTITAN PX compression sleeves, size 40

RAUTITAN PX compression sleeve in size 40 need to be compressed with the black compression jaws size 40.

✓ Previous compression jaws (gold-yellow) of other sizes, e.g. 16, 20, 25, 32, 50 and 63, can still be used without restriction.



- Only compress RAUTITAN PX compression sleeves, size 40, with the RAUTOOL compression jaws (black) size 40.
 - Only make compression sleeve joints with RAUTOOL tools.
- If other tools are to be used when making the joint, these must be approved by the corresponding manufacturer for use with RAUTITAN system and especially for use with RAUTITAN PX / PXsr fittings and compression sleeves.

05 Transport and storage

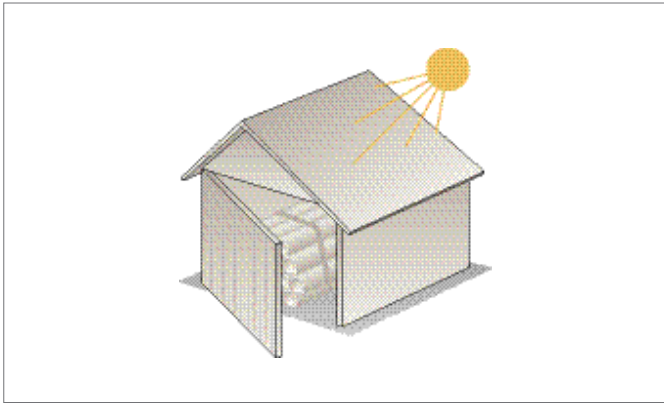

Fig. 5 - 1 Protect pipes against sunlight

Protect pipes and fittings against UV radiation during storage and transportation. When laying in areas where UV-radiation (e.g. sunlight, neon light) can occur, cover the piping fully with UV-proof material.

Avoid damaging the pipes and system components:

- Load and unload with due care.
- Only transport in a fashion suitable for the material.
- Do not drag over floors or concrete surfaces.
- Store on a flat surface with no sharp edges.
- Protect against mechanical damage.
- Protect against dirt, drilling dust, mortar, grease, oil, paint, solvents, chemicals, humidity, etc.
- Protect against sunlight, e.g. with an opaque film or similar material.
- Protect against long sunlight exposure during the construction phase.
- Only unpack shortly before laying.
- For hygiene reasons, cap or seal open pipe ends and protect pipes and fittings from contact with harmful substances.

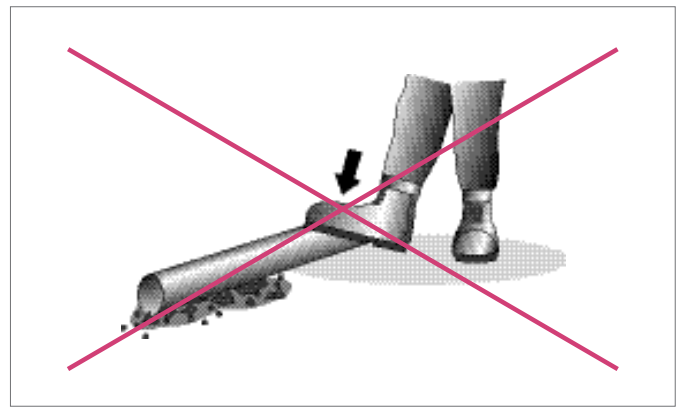

Fig. 5-2 Do not store pipes on sharp-edged surfaces

06 Making the compression sleeve joint

- ✓ - Universal REHAU compression sleeve jointing technology
- Permanently sealed joint
- Without O-ring (self sealing pipe material)
- Easy visual inspection
- Can be immediately pressurised
- Pipe doesn't need to be calibrated or deburred
- Robust jointing technology, highly suitable for construction sites

i The REHAU compression sleeve jointing technology for sizes 16-32 mm is described below. Directions for tool handling and making the joint in other pipe sizes are described in the respective operating instructions.

globe Operating instructions can be downloaded from www.rehau.com.au or www.rehau.co.nz.

- !** - Only make compression sleeve joints with RAUTOOL. If foreign tools are to be used when making the joint, these must be approved by the corresponding manufacturer for use with RAUTITAN system and especially for use with RAUTITAN PX/PXsr fittings and compression sleeves.
- Only make the joint with the appropriate installation tools. Please observe the Technical Information and the corresponding operating instructions and instruction leaflets for information on handling the tools and making joints.
- Do not use dirty or damaged connection components or tools.
- The battery and mains operated tools such as A-light 2, A3, G2 are not suitable for permanent operation. After approx. 50 consecutive clamping operations, a break of at least 15 min. is required to allow the tool to cool down.
- The range of connection components can be found in the latest product book.

Installation temperature

- Minimum installation temperature is $-10\text{ }^{\circ}\text{C}$.
- Maximum installation temperature is $+50\text{ }^{\circ}\text{C}$.

6.1 Jointing procedure

6.1.1 Cutting the pipe

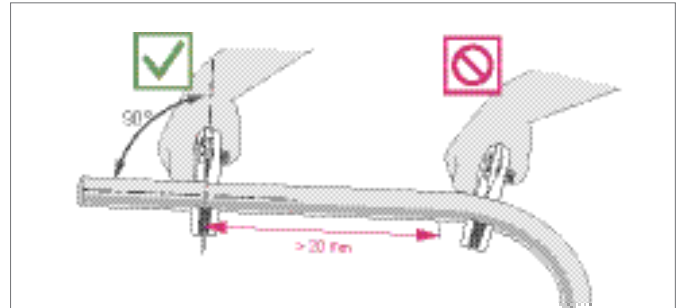

Fig. 6-1 Cut the pipe at 90° and without burrs

1. Select the appropriate pipe cutter (refer to Tab 4-1 and 4-2).
2. Cut the pipe at 90° and without burrs.



- Check the blade of the pipe cutters regularly for damage and replace the blade or the cutters as necessary. Damaged or blunt blades can cause burrs or notches on the pipes, which can tear when the pipe is expanded.
- If the pipe was cut improperly, re-cut the pipe to ensure a square and burr-free cut.
- If cracks at the expanded zone, cut off the damaged pipe end and repeat the expansion procedure.

6.1.2 Sliding the compression sleeve onto the pipe

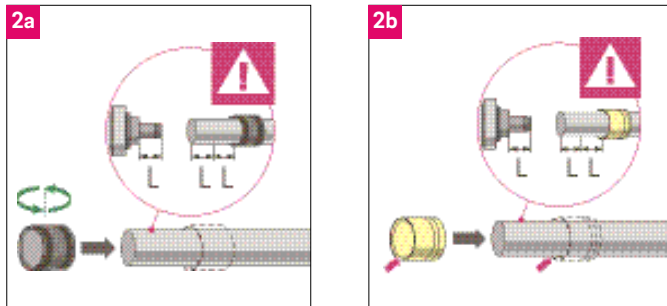
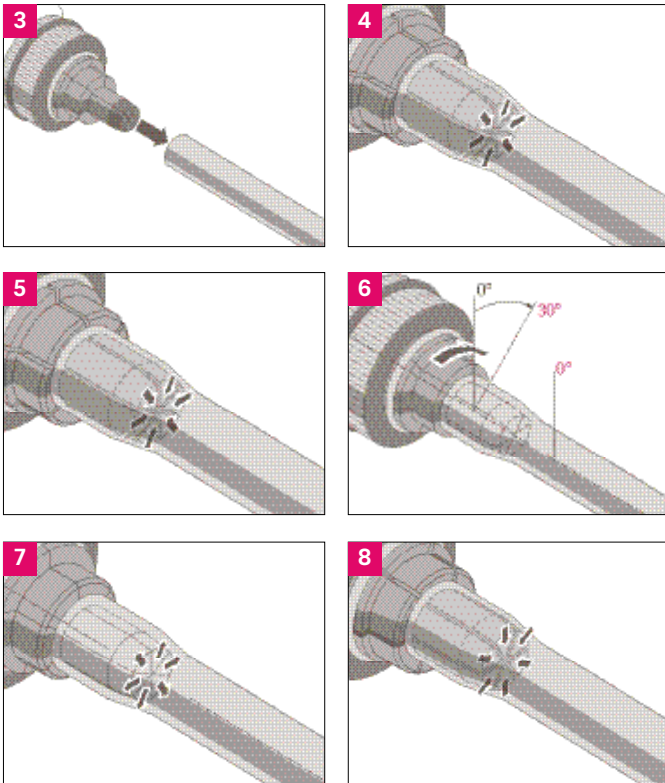

Fig. 6-2 Sliding compression sleeves PX and MX onto the pipe end

1. Ensure the pipe end (at least three times the compression sleeve length) is straight and free from any foreign material (e.g. lubricant, adhesive or tape).
2. Slide the compression sleeve onto the pipe:
 - RAUTITAN PX compression sleeve can be compressed towards the fitting from both ends, the orientation does not matter.
 - Brass compression sleeve shall be compressed with the chamfered side facing the fitting.
3. Maintain a minimum distance between the pipe end and the compression sleeve of at least twice the compression sleeve length.

6.1.3 Expanding the pipe



6.1.4 Inserting the fitting into the expanded pipe

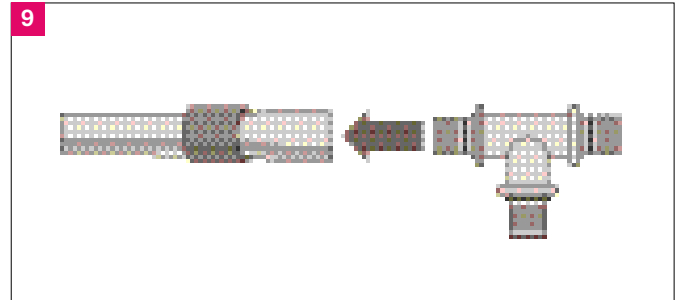

Fig. 6-9 Insert the fitting into the expanded pipe

1. Immediately after expansion, completely insert the fitting into the expanded pipe. Pipe contracts with time due to memory effect.
2. Ensure all sealing ribs are covered by the pipe.
3. Ensure joints do not move apart before compression is finished.



Only insert REHAU fittings into the expanded pipe end.

1. Select the appropriate expander head, refer to Tab 4-4 and 4-5.
2. Screw the expander heads fully onto the expansion tool.
3. Always insert the segments of the expander head completely into the pipe. Avoid skewing the expander head.
Expand the pipe once.
4. Rotate the expander tool by 30° while the pipe remains in position. Expand the pipe once again.

The pipe must have an even temperature before expansion.
Avoid local heating (e.g. by inspection lights, etc.).



- Avoid using damaged or dirty expander heads, pipes or connection components.
- Use only non-defective expander heads (e.g. not bent, broken off, fractured). Replace defective expander head.
- Maintain a minimum distance between the pipe end and the compression sleeve (at least twice the length of the compression sleeve).
- Ensure expander head does not detach during rotation.
- Always check the expansion evenness of the inner surface of the expanded pipe end (e.g. no grooves, no local overstretching of the pipe material).
- If cracks or overstretching occurs, discard pipe end and repeat.
- Regularly check expander heads for freedom of movement and dirt, clean if necessary.
- Apply REHAU grease to the cone of the expander tool only and not to the expansion segments.

6.1.5 Compressing the joint

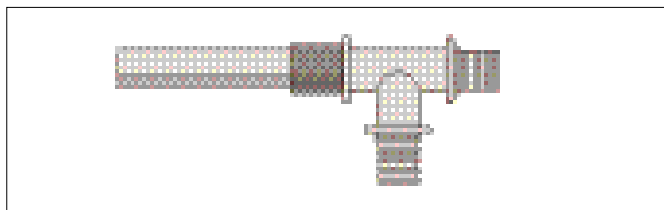
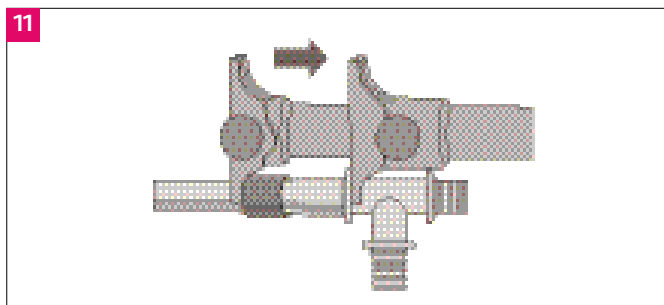
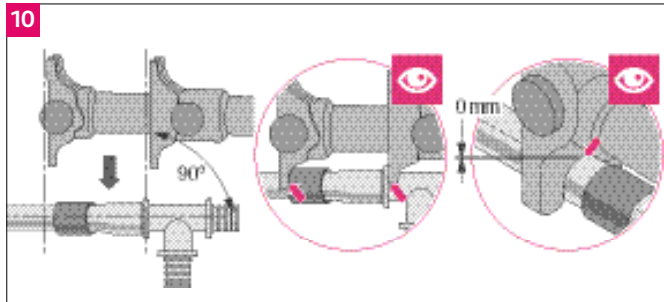

Fig 6-10 Place the fitting and compression sleeve in between the jaws.

1. Place the compression sleeve joint onto the compression tool at 90°.
2. Push the compression sleeve fully up to the fitting collar.
3. Visually inspect the joint for damages and incomplete compression.

Keep the tool clean and lubricated and store in a cool dry place.



Bulging of brass compression sleeves may occur (e.g. when using older expander heads with RAUTITAN PE-Xa pipes) but does not impair the quality of the joint. To avoid bulging, stop compressing approx. 2 mm from the fitting collar. This does not apply to RAUTITAN stabil and RAUTITAN gas stabil pipes.



- Perform jointing only on a straight pipe section (not on pipe bend). The straight pipe section must be at least three-times the compression sleeve length.
- Avoid skewing of the tool jaw onto the pipe while maintaining full contact of the tool jaws with the fitting barb and compression sleeve.
- Avoid using lubricants, water, etc. when making the compression sleeve joint.

07 Installation guidelines - water and gas



For detailed information on planning, installation and operation of REHAU systems for underfloor heating/cooling with heating pipes RAUTHERM S AND RAUTITAN pink, refer to Technical Information "Underfloor heating/cooling".

7.1 General

- Do not use dirty or damaged system components, pipes, fittings, compression sleeves or seals.
- Make sure that the connection components are free of inadmissible stress during assembly and when in operation. Make sure that the piping has sufficient scope of movement (e.g. from deflection legs).
- When flat-sealed joints (or similar) are opened, check that the sealing surface is undamaged before reconnecting and insert a new seal if necessary.



Installation temperature

- Minimum installation temperature is -10°C
- Maximum installation temperature is $+50^{\circ}\text{C}$

7.2 Protection against corrosion and damage

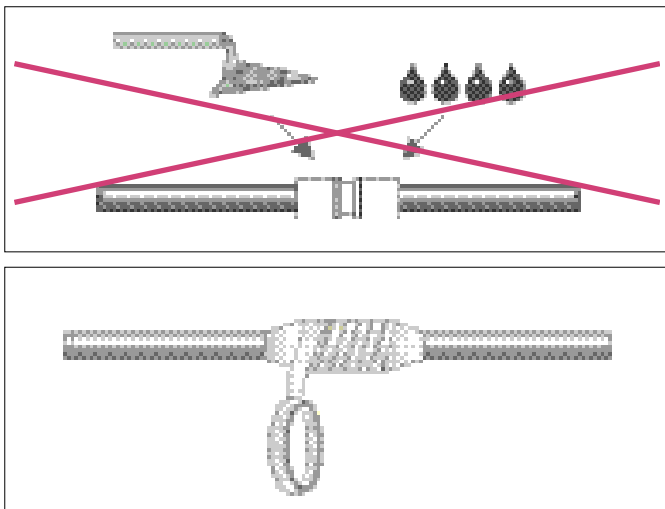

Fig. 7-1 Protect connection components against corrosion and damage



- Do not use dirty or damaged system components, pipes, fittings, compression sleeves or seals.
- Screed, cement, mortar, plaster, bonding agents and other materials and substances may cause corrosion. Where a contact with such substances is foreseeable, protect fittings and compression sleeves from contact.
- Fittings, pipes and compression sleeves shall not be installed in wet areas (ie. green houses, indoor pools, conditions where water or condensation on the surfaces must be expected on a regular basis, etc.)
- In aggressive environments (e.g. encased in concrete, cleaning agents), protect pipes and fittings against corrosion adequately and in such a way that they are sealed against vapours (e.g. to aggressive gases, chloride mediums).
- Protect the system against damage (e.g. during the construction phase and when installed in areas with vehicles or machines).
- Ensure that the employed sealants, cleaning agents, building foams, insulation, protective tape, adhesive tape, thread sealant, glue, markers etc. do not contain any substances which cause stress cracking or corrosion, e.g. ammonia, ammonia-bearing, aromatic and oxygenated solvents (e.g. ketone and ether), chlorinated hydrocarbons or chloride ions which can leach. This substances mentioned here reflects our current knowledge of substances that may be part of chemicals used on construction sites which cause stress cracking or corrosion to RAUTITAN fittings, pipes or compression sleeves; any new substance that may be forthcoming in the future may not be compatible will be excluded from this warranty upon notification.
- Protect RAUTITAN fittings, pipes and compression sleeves from contact with grease and oil, primers, solvents, glues/adhesives, paint and lacquer and other harmful substances. If incidental contact occurs, confirm compatibility with RAUTITAN fittings, pipes and compression sleeves.



Water additives

The piping can be damaged when using inhibitors, antifreeze agents or other heater water additives. Approval must be obtained from the respective manufacturers and from our Applications Department. In this case, please consult your REHAU sales office.



PX fittings made of PPSU

- Only use leak detection agents (e.g. foaming agents), sealants, thread sealants, cleaning agents, insulation, protective tape, adhesive tape and flux, which were approved by the respective manufacturer for PPSU.
- Avoid contact with building foams using a suitable product (e.g. protective tape RAUTITAN).
- When using the connection components, check the compatibility of materials for the corresponding area of application.
- Contact with aromatic and oxygenated solvents (e.g. ketone and ether) as well as halogenated hydrocarbons (e.g. chlorinated hydrocarbons) is not permitted.
- Contact with water-based acrylic paints and adhesive/protective primers is not permitted.



PX compression sleeves and PXsr fittings

- RAUTITAN PXsr fittings are solvent resistant and have excellent resistance against most aliphatic and aromatic hydrocarbons and Chlorine. Solvent resistant means that PXsr fittings made of PVDF are not susceptible to environmental stress cracking when in contact with solvents found in glues, primers and thread sealants commonly used on building sites.
- Only use leak detection agents (e.g. foaming agents), sealants, thread sealants, cleaning agents, building foams, insulation, protective tape, adhesive tape and flux, which were approved by the respective manufacturer for PVDF.
- When using the connection components, check the compatibility of materials for the corresponding area of application.
- Contact with basic environments with $\text{pH} \geq 12$ is not permitted.

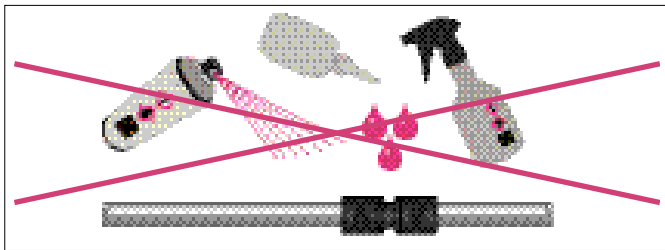

Fig. 7-2 RAUTITAN PX (PPSU): Avoid contact with solvents and oils including paints, lacquer, liquid thread sealant and tapping oil.

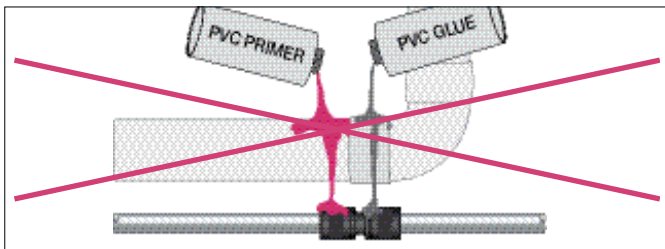

Fig. 7-3 RAUTITAN PX (PPSU): Avoid contact with primers and glues (e.g. PVC primer, PVC glue; insulation foam glue)

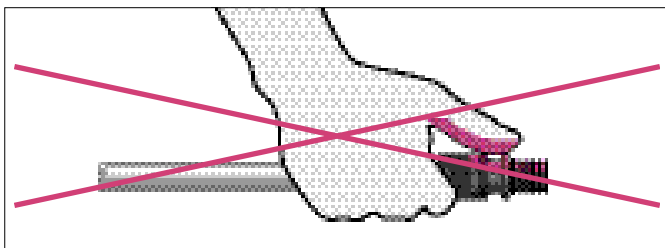

Fig. 7-4 RAUTITAN PX (PPSU): Avoid contact with aggressive substances

7.3 Pipe support and fixing

7.3.1 Pipe brackets and clips

Use only pipe brackets and clips with the following properties:

- Suitable for plastic pipes
- Improved acoustic properties through rubber lining
- Correct size (to allow easy gliding of pipe without pulling the rubber lining out)
- Free of burrs

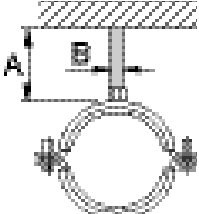
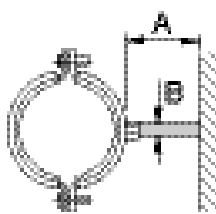
	B	A
Pipe size [mm]	Thread diameter or pipe nipple diameter	Maximum distance of wall/ceiling to the pipe clamp [mm]
		
16	M8 M10 M12 M16	100 150 200 300
20	M10 M12 M16	100 150 250
25	M12 M16	100 200
32	M16 R ½	100 150
40	R ½ R¾ R1	100 150 220
50	R¾ R1	100 200
63	R1	150

Tab. 7-1 Guideline values for fixing parameters of anchor points

7.3.2 Anchor points

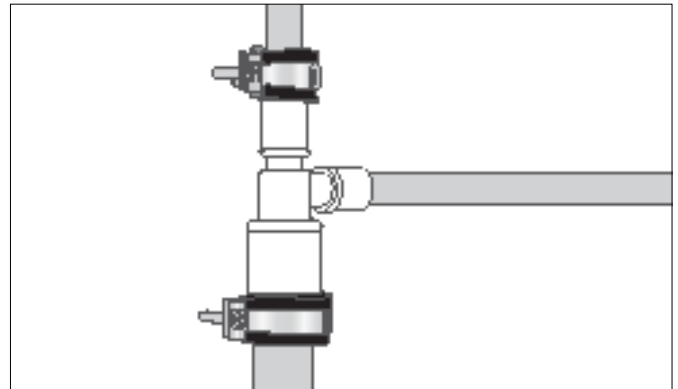

Fig. 7-5 Anchor point made by pipe clamps

- Anchor points can be used to restrict the thermal linear expansion into one direction.
- Long pipe run can be divided into several sections by adding several anchor points.
- Anchor points can be fixed at tees, elbows or connectors. Anchor points can be fixed by installing a pipe bracket directly before each compression sleeve of the fitting



Pipe brackets shall not be installed on compression sleeves.

7.3.3 Spacing between brackets and clips

Choose the correct pipe spacing intervals according to the guideline values (see Table 7-2 and 7-3) for installation with or without pipe support channels.





7.3.4 Exposed installation

When installing pipe at exposed areas or installing long piping without change in direction, we recommend using pipe support channel for RAUTITAN PE-Xa pipes.



- For installation without pipe support channel, install anchor points at 6 m intervals.
- Ensure that there is sufficient space for piping to expand.



For installation of RAUTITAN PE-Xa pipes without pipe support channel, pipe sagging is to be anticipated.

RAUTITAN PE-Xa pipes	Size	Horizontal installation			Vertical installation		
		Concealed	Exposed	REHAU support channel	Concealed	Exposed	REHAU support channel
		Max. recommended spacing of bracket and clips (m)			Max. recommended spacing of bracket and clips (m)		
	16	0.60	0.30	2.0	1.20	1.20	2.0
	20	0.70	0.40	2.0	1.40	1.40	2.0
	25	0.75	0.50	2.0	1.50	1.50	2.0
	32	0.85	0.70	2.0	1.70	1.50	2.0
	40	0.90	0.90	2.0	1.80	1.50	2.0
	50	1.05	1.05	2.0	2.10	1.50	2.0
	63	1.10	1.10	2.0	2.20	1.50	2.0

Tab. 7-2 Recommended spacings of pipe bracket/clip for RAUTITAN PE-Xa pipes

Multilayer composite pipe	Size	Max. recommended spacing for bracket and clips (m)
	16	1.00
	20	1.25
	25	1.50
	32	1.75
	40	2.00

Tab. 7-3 Recommended spacings of pipe bracket/clip for metal composite pipes

7.4 Pipe support channel

7.4.1 Benefits of using pipe support channel

- ✓ - Reduces thermal expansion length
- Clip effect increases the axial retaining force
- Stabilizes the pipes against sagging and sideways bending
- Increases rigidity
- Increases the pipe clamp interval to 2 m regardless of the pipe size
- Visually appealing installations in exposed areas with RAUTITAN PE-Xa pipes
- Simple assembly
- Self-supporting
- Clipped onto the pipe

7.4.2 Functionality

The pipe support channel covers the pipe by about 60 % and is shaped to closely encase the pipe without additional fastenings. This strong clamping effect prevents the pipe from bending and reduces thermal expansion in length.

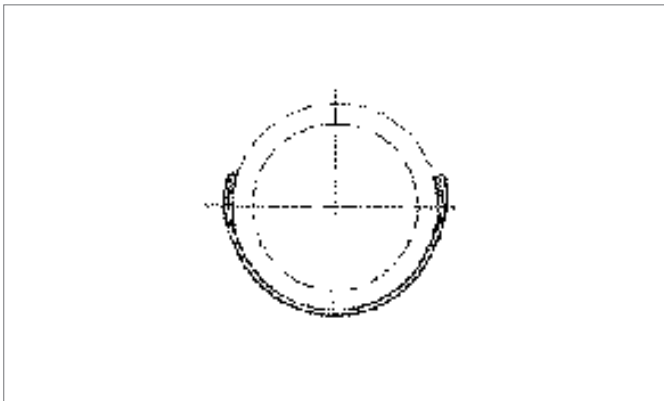

Fig. 7-6 Cross-section of pipe support channel

7.4.3 Assembly of the pipe support channel

Do not fit pipe support channel or pipe fasteners close to the deflection legs so the pipe can still bend.
Pipe cover

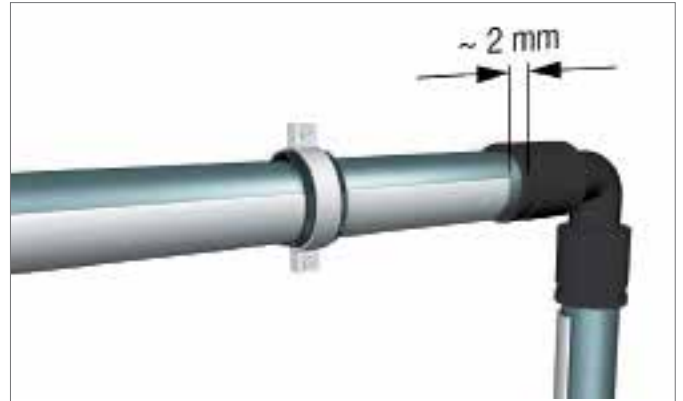

Fig. 7-7 Let the pipe support channel end approx. 2 mm before compression sleeve

The pipe support channel must be fitted over the entire length of the piping up to 2 mm before the compression sleeve, as only this ensures reduction of the thermal expansion length.
Pipe clamp intervals



Fig. 7-8 Maximum pipe clamp intervals

The maximum pipe clamp interval when using the pipe support channel is 2m for all sizes. The distance from the pipe end, or when changing direction, to the first pipe fastener may not exceed 0.5 m. This way, pipe brackets for pipe routing or in cellars can be attached in a uniform and effective manner.

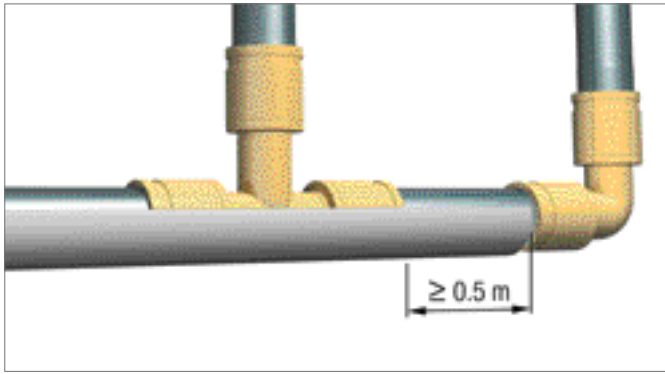

Fig. 7-9 Minimum overlapping of 0.5 m

Fittings with brass compression sleeve sizes 50 and 63 can be clipped by the pipe support channel if the pipe support channel projects at least 0.5 m beyond the compression sleeve. With this kind of installation, cutting off the pipe support channel at the fitting is not necessary.

Clipping over the fitting is not possible when using RAUTITAN PX compression sleeves.

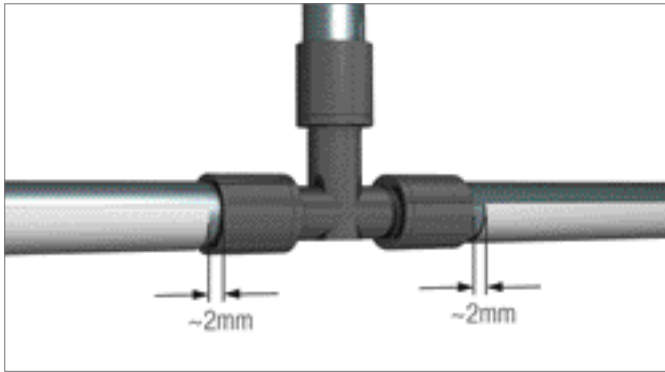

Fig. 7-10 Do not clip over RAUTITAN PX compression sleeve

Assembly of the pipe support channels

Reduced retaining force of the pipe support channel can cause greater thermal expansion of the pipe.

Do not lessen the retaining force of the pipe support channels by storing or assembling them improperly.

1. Cut off the pipe support channel with a metal saw (see Fig. 7-11). Maintain a safe distance between your holding hand and the cutting tool. Saw pipe support channels from the rounded rear side, not the open side so that they are not bent open at their bordered ends.

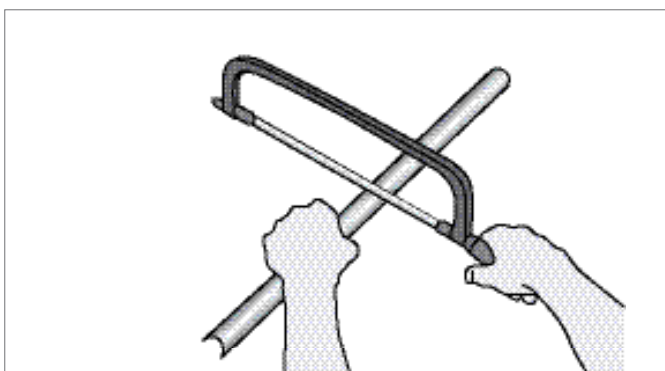

Fig. 7-11 Cutting off pipe support channel

2. If the pipe support channel has been bent inwards or outwards when it was cut to length, bend the pipe support channel back to its original shape.
3. Deburr the ends of the pipe support channel.

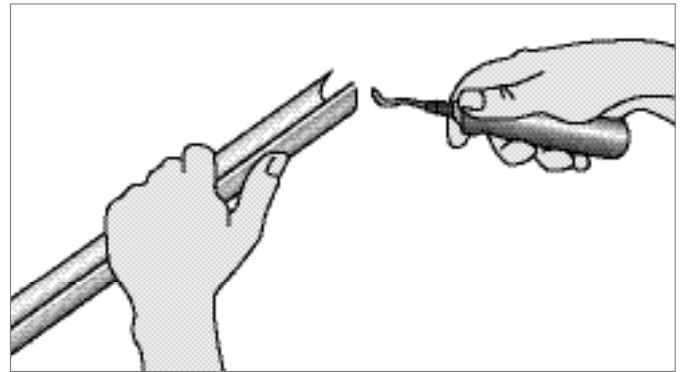

Fig. 7-12 Deburring of pipe support channel

4. Clip the pipe support channel onto the pipe (by hand or using a pliers or pipe wrench with plastic jaws). Do not overlap the ends of pipe support channels.

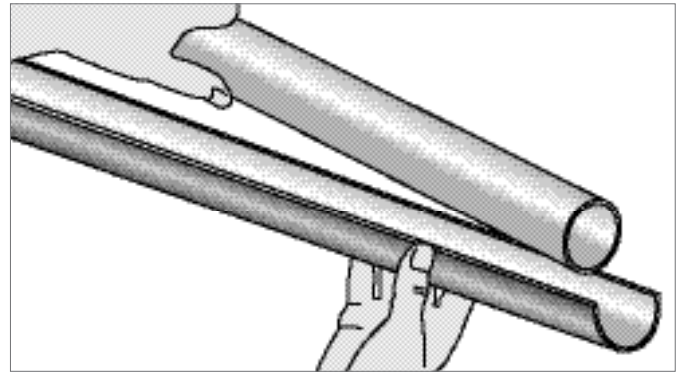

Fig. 7-13 Clipping in pipe support channel

5. To join support channels together, use cut-offs clipped over both ends.

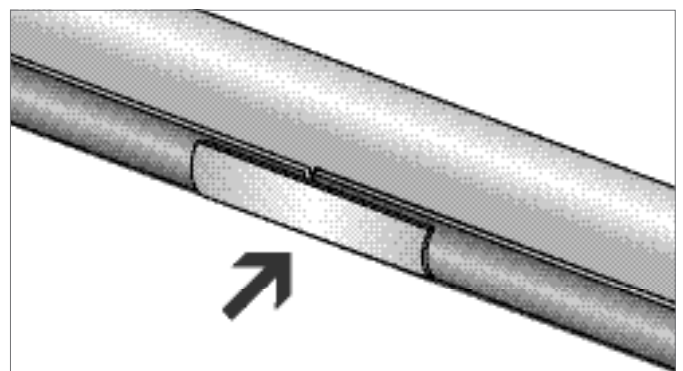

Fig. 7-14 Joining two pipe support channels

Even short cut-offs of the pipe support channel can be used for clipping over joints, ensuring an almost waste-free installation.

7.5 Pipe bending

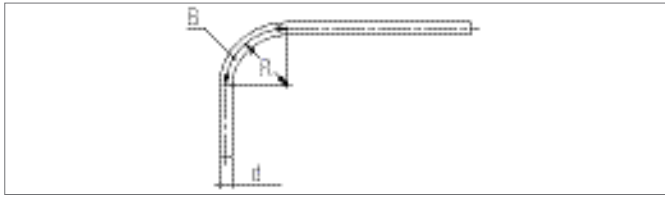

Fig. 7-15 Pipe bend

R Bending radius
B Arc
d Pipe diameter

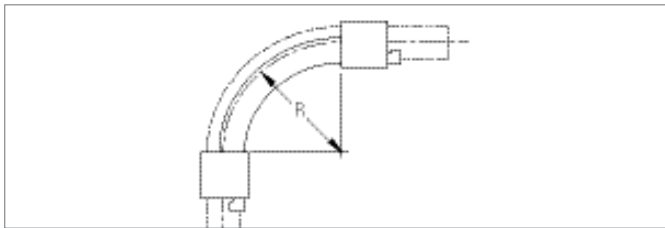

Fig. 7-16 Pipe bend bracket for plumbing 90 degrees, for size 16– 32 and pipe bend bracket for plumbing/heating 5 x d 90 degree for size 32

R Bending radius

RAUTITAN stabil and RAUTITAN gas stabil pipe can be bent either by hand or by using a bending tool. *

Minimum bending radius

- When bending without tools, the minimum bending radius is five times the pipe diameter.
- When bending with a spiral spring, the minimum bending radius is three times the pipe diameter.
- The minimum bending radius is measured with respect to the centre of the pipe.
- After bending, ensure that there are no kinks, wrinkles or bulges and that the outer PE sheath and aluminium layer are undamaged.



Only cold bending of pipes RAUTITAN stabil and RAUTITAN gas stabil is allowed.

7.5.1 Bending RAUTITAN stabil and RAUTITAN gas stabil

	RAUTITAN stabil		RAUTITAN gas stabil	
	Bent with bending tool (90°) 3 x d		Bent by hand (90°) 5 x d	
Pipe sizes	Bending radius R [mm]	Arc B [mm]	Bending radius R [mm]	Arc B [mm]
16	48.6	76	81	127
20	60	94	100	157
25	75	118	125	196
32	96	151	160	251
40	120	188	200	314

Tab. 7-4 Minimum bending radii of RAUTITAN stabil and RAUTITAN gas stabil pipe

7.5.2 Bending RAUTITAN platinum, RAUTITAN red, RAUTITAN green and RAUTITAN lilac

	RAUTITAN platinum		RAUTITAN red		RAUTITAN green		RAUTITAN lilac	
	Using pipe bend brackets for plumbing (90°) 3 x d		Using pipe bend brackets for plumbing/heating (90°) 5 x d		Bent by hand (90°) 8 x d			
Pipe sizes	Bending radius R [mm]	Arc B [mm]	Bending radius R [mm]	Arc B [mm]	Bending radius R [mm]	Arc B [mm]	Bending radius R [mm]	Arc B [mm]
16	48	75	80	126	128	201		
20	60	94	100	157	160	251		
25	75	118	125	196	200	314		
32	112	176	160	251	256	402		

Tab. 7-5 Minimum bending radii of RAUTITAN PE-Xa pipes

* For approved bending tools for RAUTITAN stabil and gas stabil pipes contact your local REHAU sales office.

7.6 Provision for thermal expansion

7.6.1 Calculating thermal length changes

The thermal change in length is calculated with the following equation:

$$\Delta L = \alpha \cdot L \cdot \Delta T$$

ΔL	=	Length change in mm
α	=	Coefficient of linear thermal expansion in $\frac{mm}{m \cdot ^\circ C}$
L	=	Length of piping in m
ΔT	=	Temperature difference in $^\circ C$

The coefficient of linear thermal expansion must be selected according to the installed pipe type and if pipe support channel is installed.

Determining the pipe length

The pipe length L is the actual installed pipe length on site between anchor points, expansion bends or loops. Sometimes it may be necessary to divide the pipe run into several sections by adding anchor points or expansion bends and loops to limit the change in length per section.

Determining the temperature ΔT

To determine the temperature difference ΔT , the following shall be taken into consideration:

- Installation temperature or minimum operating temperature (e.g. when the system is out of service)
- Maximum operating temperature (e.g. thermal disinfection)

Pipe type	Pipe size	Coefficient of linear thermal expansion α [$\frac{mm}{m \cdot ^\circ C}$]	Material constant C
		$\Delta L = \alpha \cdot L \cdot \Delta T$	$L_{DL} = C \cdot \sqrt{d_o \cdot \Delta L}$
RAUTITAN stabil	16–40	0.026	33
RAUTITAN gas stabil			
RAUTITAN platinum	16–63 without REHAU support channel	0.15	12
RAUTITAN red	16–40 with REHAU support channel	0.04	–
RAUTITAN green			
RAUTITAN lilac	50–63 with REHAU support channel	0.1	–

Tab. 7-6 Coefficient of linear thermal expansion (approximate values) and material constants for deflection leg calculation (approximate values)

7.6.2 Deflection legs

Thermal length changes can be accommodated by deflection legs. RAUTITAN PE-Xa pipes are particularly suitable for this due to their flexibility.

A deflection leg is the freely moveable pipe length, which can take up the required thermal length changes. The length of the deflection leg is influenced mainly by the material (material constant C).

Deflection legs result mostly from changes in direction of the piping. For long piping lengths, additional deflection legs must be installed in the piping to compensate the thermal length changes.



Do not fit pipe support channels or pipe brackets on deflection legs as this would restrict their flexibility.

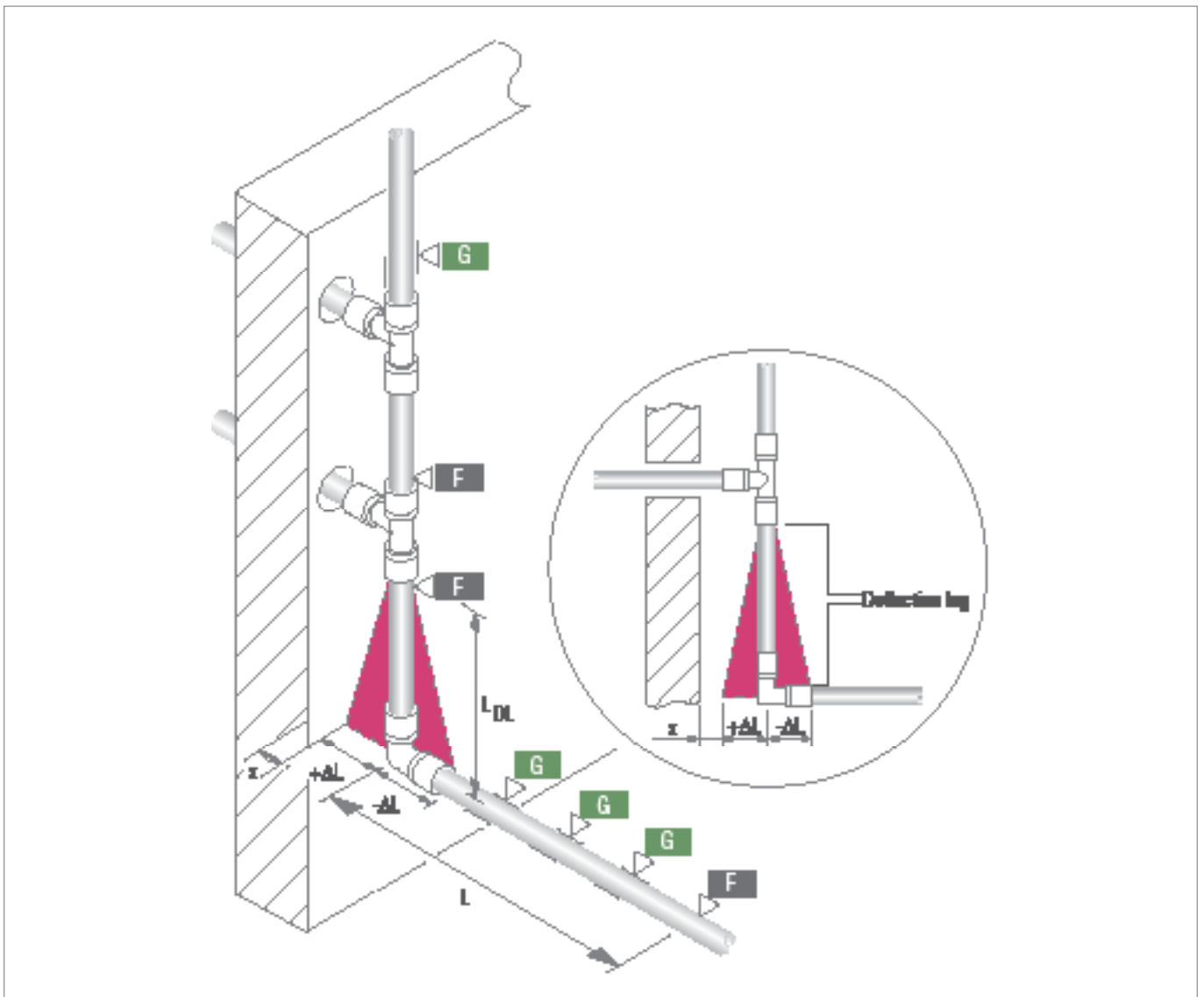

Fig. 7-17 Deflection legs

- L_{DL} Length of deflection leg
- ΔL Thermal length change
- L Pipe length
- x Minimum distance of the pipe from the wall

- F** Fixed/anchor point
- G** Gliding point (loose)

7.6.3 Calculation of deflection leg length

The minimum length of deflection length (DL) is calculated by the following formula:

$$L_{DL} = C \cdot \sqrt{d_o \cdot \Delta L}$$

- L_{DL} = Length of deflection leg
- d_o = Outer pipe diameter in mm
- ΔL = Length change in mm
- C = Material constant of piping material



For approximate values for material constant C, see Table 7-6.

Do not fit pipe support channels or pipe brackets close to the deflection legs so it will not be prevented from bending.

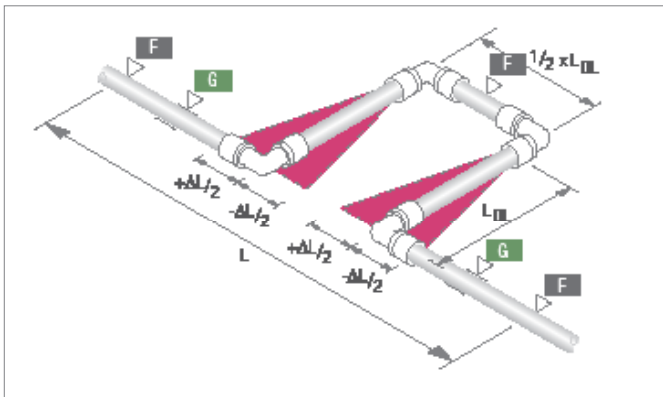

Fig. 7-18 U expansion bends.
 L_{DL} Length of deflection leg
 ΔL Thermal length change
 L Pipe length

7.6.4 Calculation examples

The pipe length L, for which the thermal length changes is to be accommodated at a deflection length, is 7m.

The temperature difference between the minimum and maximum values (installation temperature and subsequent operating temperature) is 50 °C. The installed pipe outer diameter is 25mm.

What length of deflection leg is required according to the installed pipe type?

Calculation of deflection leg length with RAUTITAN stabil and RAUTITAN gas stabil

$$\Delta L = \alpha \cdot L \cdot \Delta T$$

$$\Delta L = 0.026 \frac{mm}{m \cdot ^\circ C} \cdot 7m \cdot 50^\circ C$$

$$\Delta L = 9.1 mm$$

$$L_{DL} = C \cdot \sqrt{d_o \cdot \Delta L}$$

$$L_{DL} = 33 \cdot \sqrt{25mm \cdot 9.1 mm}$$

$$L_{DL} = 498 mm$$

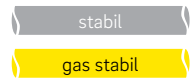

Calculation of deflection leg length with RAUTITAN PE-Xa pipes installed with REHAU support channel

$$\Delta L = \alpha \cdot L \cdot \Delta T$$

$$\Delta L = 0.04 \frac{mm}{m \cdot ^\circ C} \cdot 7m \cdot 50^\circ C$$

$$\Delta L = 14 mm$$

$$L_{DL} = C \cdot \sqrt{d_o \cdot \Delta L}$$

$$L_{DL} = 12 \cdot \sqrt{25mm \cdot 14 mm}$$

$$L_{DL} = 224 mm$$



Assessment of the results

RAUTITAN stabil and RAUTITAN gas stabil have lower thermal change length than RAUTITAN PE-Xa pipes due to its aluminium layer. However, the required deflection leg length for RAUTITAN PE-Xa is shorter due to the flexible pipe material. For metallic pipe materials, a substantially larger deflection leg is required for the same operating parameters during installation, due to the significantly higher material constant (C), than for other RAUTITAN pipes system.

7.7 Installing threaded fittings

General installation requirements

- Avoid over-tightening threaded joints.
- Only use sealants approved for gas and water installation.
- Do not apply excessive hemp to threaded joints.
The thread tips must be visible.
- Use open-end wrenches in the right size. Do not clamp fitting too tightly into the vice.
- Pipe wrenches may cause damage to the fittings and compression sleeves.
- Do not extend the leverage of installation tools, e.g with pipes.

Compatibility of different thread types

- Only the following thread types may be used with RAUTITAN system:
Sealing threads in accordance with ISO 7-1 (AS 1722.1) and EN 10226-1:
 - Rp = cylindrical female thread
 - R = tapered male thread
 Fastening pipe threads in accordance with ISO 228 (AS 1722.2):
 - G = cylindrical thread, non-sealing in thread
- Check compatibility of different thread types before screwing them together, e.g. tolerances, free movement.
- Only use an appropriate G male connector with flat sealing thread fittings with G female thread.
- If using long threads, ensure the maximum possible screwing depth and sufficient thread depth in opposing parts with inside threads.

7.8 Transition to other pipe materials

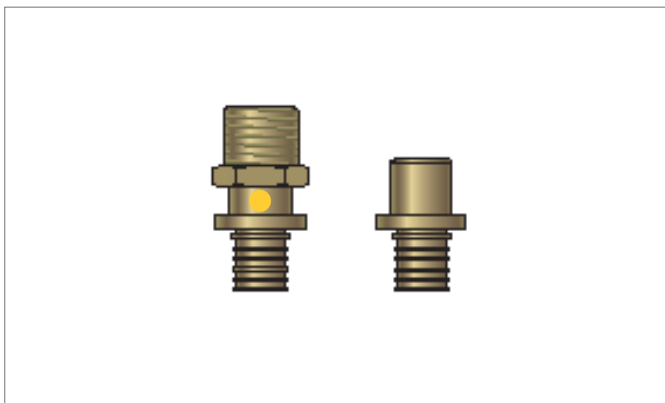

Fig. 7-19 RAUTITAN MX, RAUTITAN RX+/EX+ and RAUTITAN ONE fittings for transitions to other materials



Gas piping

- Only use RAUTITAN ONE threaded adapters for the transition to other pipe materials.
- A direct transition to stainless steel installation system is not permitted. Use a non-stainless steel interim piece for the connection of both systems, e.g. a combination of: RAUTITAN ONE threaded adapter with male thread – threaded socket – threaded adapter with male thread made of stainless steel.
- Only use mating threads according to AS 1722.1, ISO 7-1 and EN 10226-1 (Rp/R).

Water piping

- A direct transition to stainless steel installation system is not permitted. Use a non-stainless steel interim piece for the connection of both system, e.g. a combination of: RAUTITAN MX, RAUTITAN RX+/EX+ or RAUTITAN ONE threaded adapter with male thread - threaded socket - threaded adapter with male thread made of stainless steel. A transition piece made of gunmetal between both fittings is recommended.
- Only use mating threads according to AS 1722.1, ISO 7-1 and EN 10226-1 (Rp/R).

Brazing connections

- Brazing joints shall be made before connecting to RAUTITAN system.
- After brazing the fitting must completely cool down before making the compression sleeve joint.

If repair works or piping network extensions include a change from an existing system to RAUTITAN system (or vice versa), threaded joints or connection barbs must be used as clear division between the different systems and to maintain warranty.

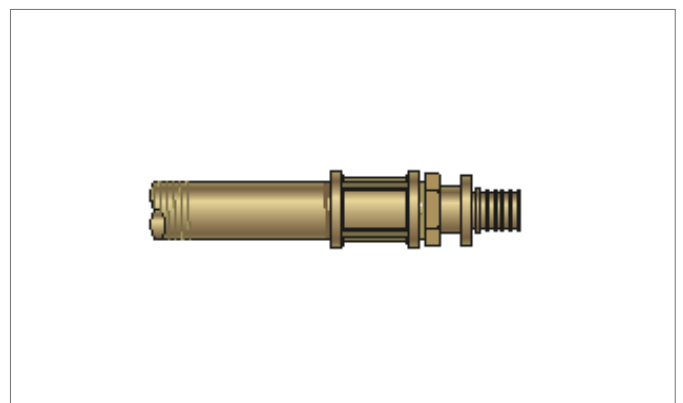

Fig. 7-20 Adapter with RAUTITAN MX male thread fixed into a threaded socket

7.8.1 Transition to copper system

For transitions from RAUTITAN system to brazed systems, use RAUTITAN connection bars. After brazing the fitting must completely cool down before making the connection to RAUTITAN system.

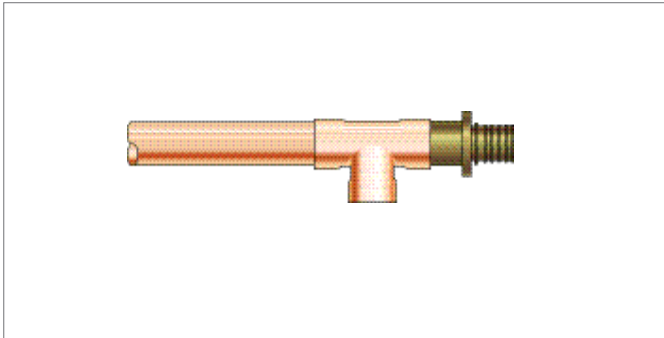

Fig. 7-21 RAUTITAN connection barb brazed to copper pipe

7.8.2 Transition to stainless steel system

There is a great difference in strength between stainless steel and dezincification-resistant brass.



- Direct transition between RAUTITAN system and stainless steel installation systems may cause leaks or damage to fittings
- Only connect RAUTITAN system to other systems made of stainless steel by interconnecting fittings (e.g. flush-mounted valves or water meters).

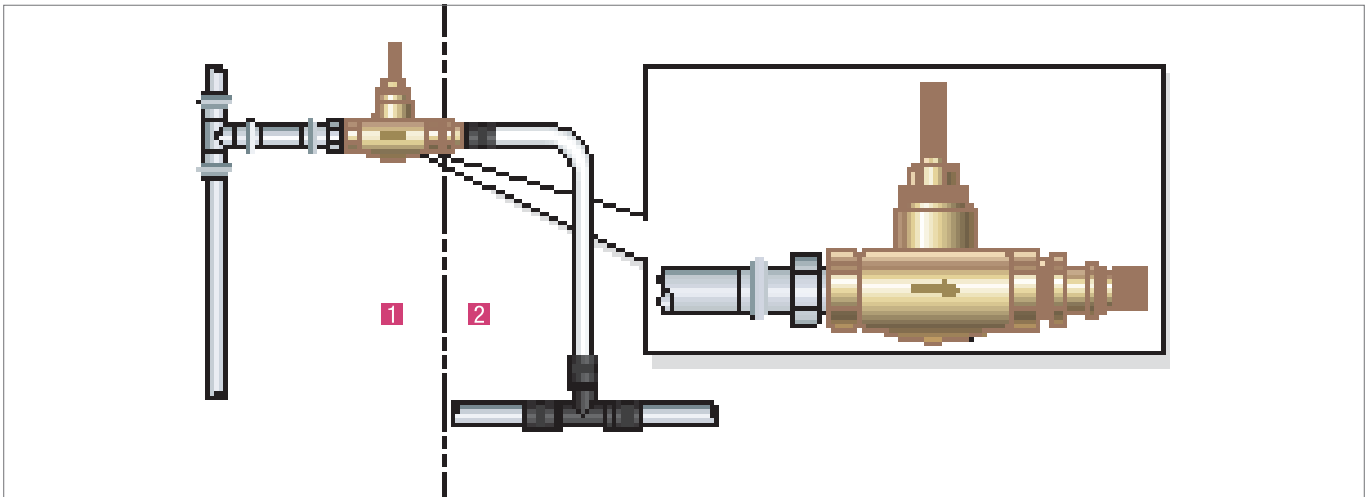

Fig. 7-22 Installation situation of a system adapter to a flush mounted valve (example)

- 1** Stainless steel system with flush-mounted valve **2** RAUTITAN system with RAUTITAN MX, RAUTITAN RX+/EX+ or RAUTITAN ONE adapters (brass)

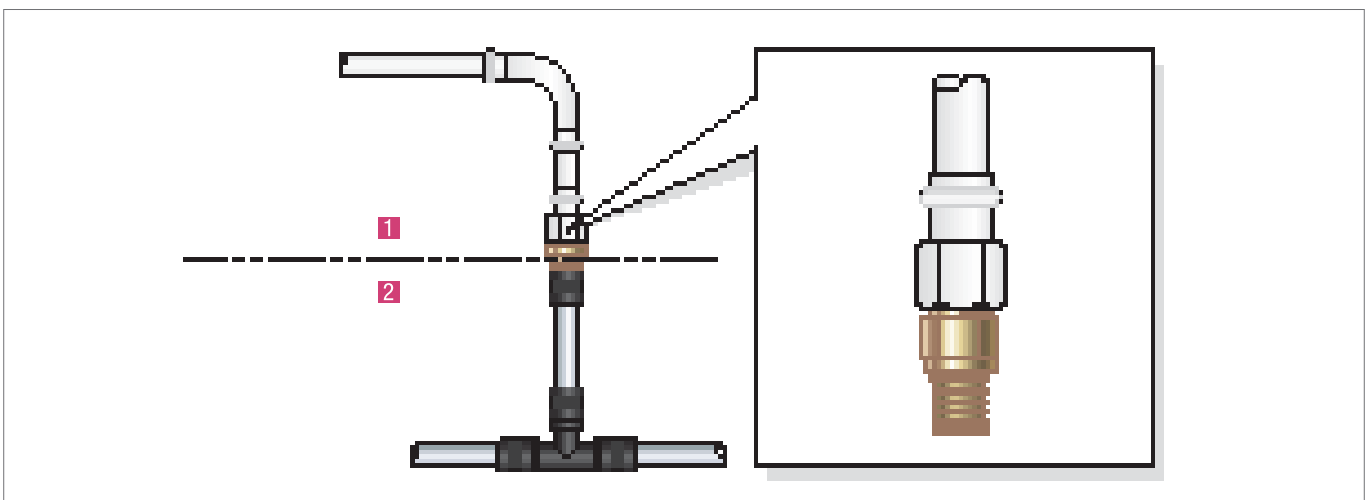

Fig. 7-23 Direct transition from stainless steel system to RAUTITAN system up to size 32 or with threads up to R1/Rp1

- 1** Stainless steel system **2** RAUTITAN system with RAUTITAN RX+ (gunmetal) (direct transition is not permitted when using RAUTITAN MX, EX+ or One adapters made of brass!)

7.8.3 Connection to fittings



Fig 7-24 Adapter with RAUTITAN union nut



Equipment and fittings can easily be connected by using adapters with union nuts.



The pipe and the thread nominal diameter has to be considered to choose an appropriate connector.
For example:
Connector 20 - G^{3/4} is appropriate for a valve DN 15 with a male thread G^{3/4}

7.9 Reusing jointing components

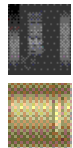
7.9.1 Reusable components

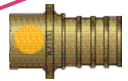
Reusable	Not reusable Dispose of together with all cut-out pipe parts		
Fittings RAUTITAN MX and RAUTITAN RX+/EX+	Compression sleeves	Fittings RAUTITAN PX / PXsr	Fittings RAUTITAN ONE
			

Tab. 7-7 Reusable jointing components



RAUTITAN ONE:

- RAUTITAN ONE components shall not be reused or detached and must be disposed.

RAUTITAN PX / PXsr, MX, EX+ and RX+:

- Dispose used RAUTITAN PX / PXsr fittings and RAUTITAN PX compression sleeves.
- Only reuse RAUTITAN MX, RAUTITAN EX+ and RAUTITAN RX+ fittings in perfect condition within the same application type from which they were removed from. Do not reuse fittings where the barb surface shows any damages. Removed metal fittings from water installations shall not be used in gas installations, even when the fitting has a yellow marking.
- Dispose detached compression sleeves with the detached pipe sections

Do not cut RAUTITAN PX polymer sleeves to reuse fittings:

- The barb surface may accidentally get damaged. A damaged barb surface may lead to leaks.
- An undisposed cut sleeve may accidentally be reused. Using a cut sleeve may lead to leaks.

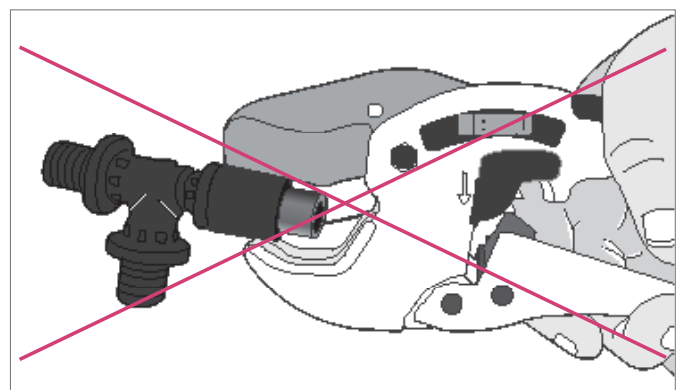

Fig. 7-24 Cutting of PX sleeves is not approved

7.9.2 Reusing RAUTITAN MX fittings



REHAU will not accept liability if these instructions are not followed (e.g. when heating up the compression sleeve joint when attached).

Step 1: Cutting out the joint

Cut the joint to be detached completely from the existing piping using a pipe cutter.

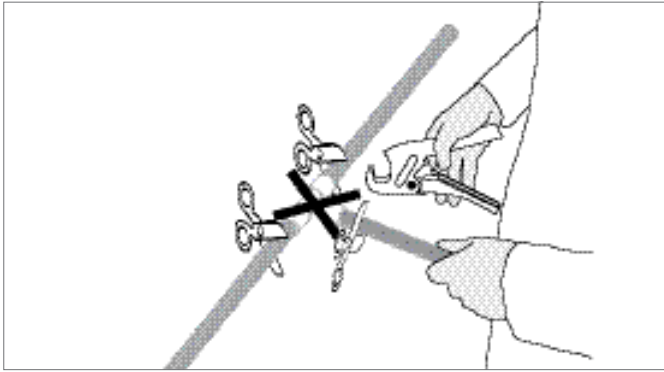

Fig. 7-25 Cutting out joint

Step 2: Heating the joint to be detached

1. Heat up the cut-out RAUTITAN MX fitting and sleeves with a heat gun.
2. When reaching a temperature of approx. 135 °C remove the sleeve from the fitting body (e.g. with pliers).



Heating up the RAUTITAN PX compression sleeve or PXsr fittings made of PVDF to over 200 °C or direct flame exposure can lead to a build-up of toxic gases.

- Do not heat RAUTITAN PX compression sleeve or PXsr fittings to over 200 °C.
- It is not permitted to burn or apply a flame to RAUTITAN PX compression sleeves or PXsr fittings.

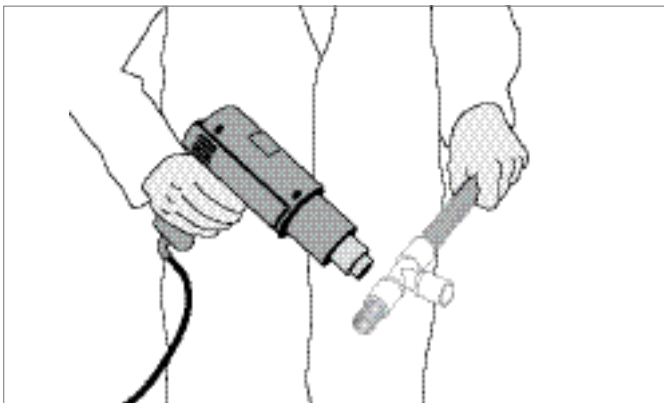

Fig. 7-26 Heating up the joint which is to be detached.

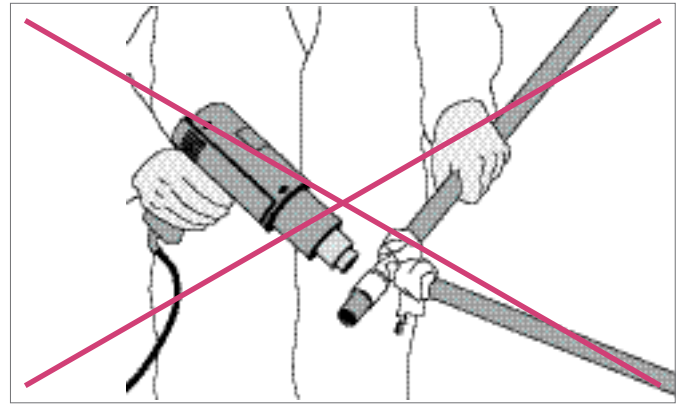

Fig. 7-27 Not permissible heating up procedure



When the joint to be detached is heated, all joints of the heated fitting are no longer sealed.

Always separate the fitting to be heated completely from the piping!

Step 3: Removing the compression sleeves

1. Remove sleeves and pipe sections from the fitting body.
2. Clean dirt from fitting.
 - When in perfect condition and cooled, RAUTITAN MX fittings can be reused in the same application.
 - Do not reuse detached compression sleeves and pipe sections.

Step 4: Dispose used sleeves and pipe sections

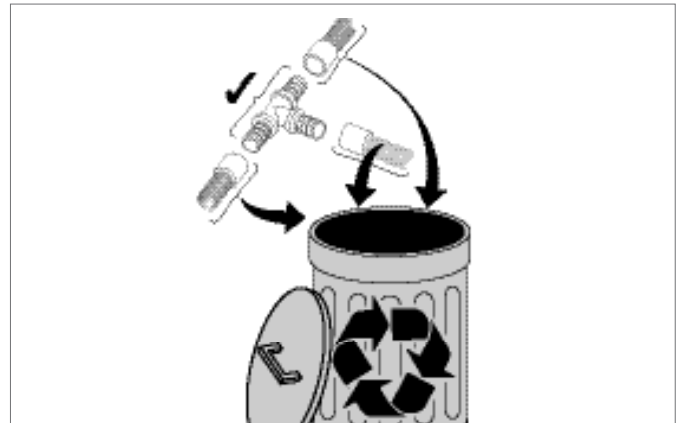

Fig. 7-28 Disposing cut out pipe sections and compression sleeves

7.10 Installation within concrete/screed floors and walls

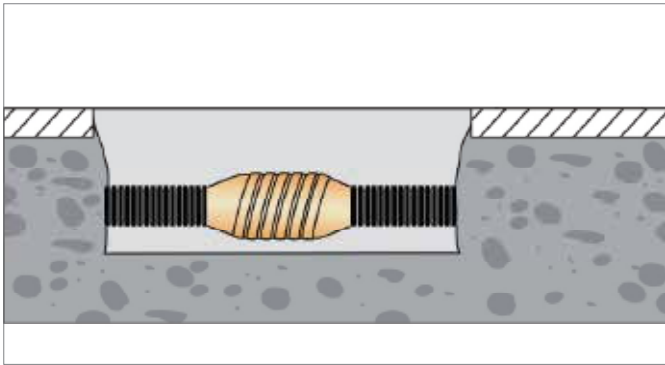

Fig. 7-29 Installation of RAUTITAN system within concrete/screed floor with corrosion protection system

Installation of RAUTITAN systems within concrete/screed floors and walls are allowed, provided specific requirements from local installation standards are fulfilled and adequate protection from mechanical damage and chemical damage are provided. Fittings shall be wrapped with suitable tape to avoid direct contact with concrete. Pipe must be laid in conduit.

7.11 Installation in areas exposed to UV radiation and light

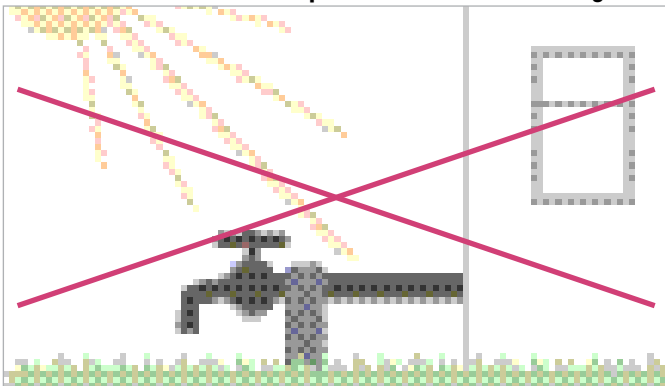

Fig. 7-30 Unprotected installation in areas exposed to UV radiation is not permitted
Example: Outdoors

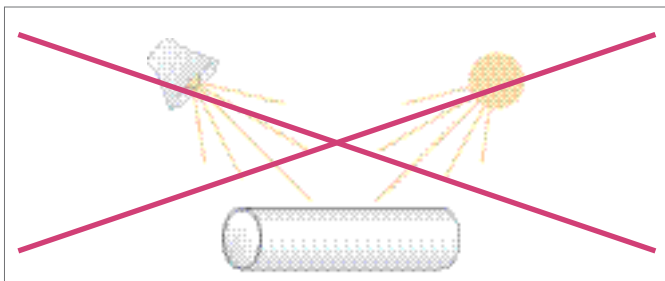

Fig. 7-31 Unprotected installation in areas exposed to UV radiation or light is not permitted. E.g. indoors



- Store and transport pipes with protection against UV radiation.
- Protect piping from UV rays in areas where UV radiation can occur (e.g. sunlight, neon light).
- RAUTITAN PE-Xa pipes shall be installed in dark areas or protected in conduit to avoid biofilm growth.

7.12 External installation above ground



All external installations shall follow the applicable water and gas installation standards.

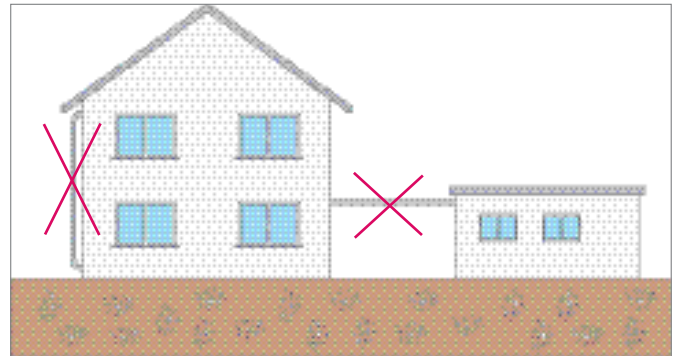

Fig. 7-32 External installation prohibited

RAUTITAN and RAUTITAN gas system components shall in general not be installed above ground, except for the following:

Gas application:

- Short pipe length after connection to gas meter before going in ground
- Connection to an external gas appliance above ground
- Connection to an above ground LPG tank

Water application:

- Short pipe length after connection to water meter before going in ground
- Connection to an externally located water heater

For the above exceptions, the following must be ensured:

- The length of pipe installed above ground shall be kept to an absolute minimum not exceeding 2 metres. Below ground installation should always be preferred.
- All pipe and connections must be adequately protected from corrosion, frost and excessive temperature.
- The system components must be protected from any mechanical and physical damages. Consideration shall be given to the type and level of damage which is likely to occur during the long term operation of the system, e.g. UV-radiation, lawn mower, etc.



For specific installation requirements for gas application, refer to chapter 10.5

7.13 Installation below ground



All below ground installations shall follow the applicable water and gas installation standards.

General

RAUTITAN and RAUTITAN gas system components can be installed in the ground if they are adequately protected against mechanical and chemical damage and contamination. Laying of RAUTITAN pipes in contaminated soil (ie. petrol, benzene, paint, solvent etc.) is not permitted.



If chemical damage is likely to occur, e.g. from termite treatments, RAUTITAN pipes and fittings shall be adequately protected using a suitable conduit, e.g. PVC pipes or equivalent.

Bedding and backfill

The quality of bedding and backfill material must be in accordance with valid national water and gas installation standards.

Corrosion protection

All joints in ground, except for RAUTITAN PX / PXsr fitting joints with RAUTITAN PE-Xa pipes, must be protected against corrosion using a recognized corrosion protection system, such as the Denso DEKOTEC N15/PE5 system or equivalent.

For installation of Denso DEKOTEC N15/PE5 corrosion protection system refer to Appendix A1.

When using an alternative Corrosion Protection System:

- Ensure chemical compatibility with RAUTITAN pipes and fittings,
- When using RAUTITAN stabil or RAUTITAN gas stabil ensure there is no adverse effect on the adhesion of the outer PE-layer to the aluminium layer,
- Only use systems which are suitable for the application and ground conditions and include an approved cavity filler/ putty that can be applied to profile the joint, allowing smooth application.

The corrosion protection system shall cover a minimum of 150 mm of the pipe on each side of the joint. Ensure mechanical protection is provided to avoid any damage to the corrosion protection tape e.g. by backfill material.



Inadequate corrosion protection of joints may cause corrosion of RAUTITAN stabil, RAUTITAN gas stabil pipes and brass fittings and lead to leakage

RAUTITAN PX / PXsr fittings and compression sleeves when installed with RAUTITAN PE-Xa pipes must be mechanically protected, i.e. by laying in a sand bed or by sliding a piece of pipe with larger diameter over the joint.

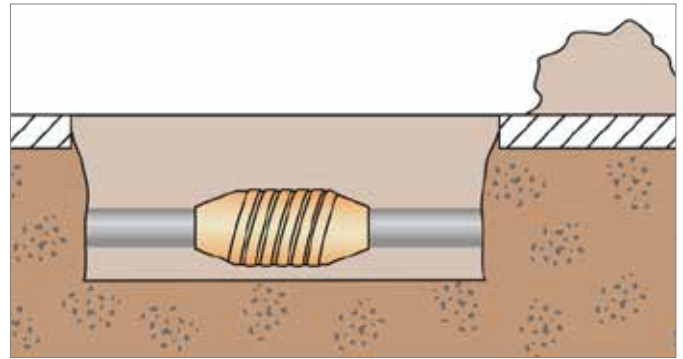

Fig. 7-33 Installation of RAUTITAN system below ground with fittings wrapped with corrosion protection system

Repair or extension works

Repair or extension works on RAUTITAN stabil or gas stabil pipes installed in ground are not permitted once the system has been put into operation.



When installed in ground and the outer PE layer of RAUTITAN stabil or RAUTITAN gas stabil pipe gets damaged, the aluminium layer may corrode with time. This may be visually unpleasant but does not affect the long term pressure resistance and performance of the pipe and is uncritical, as long as the joints have been protected from corrosion as described above.



For specific installation requirements for gas application, refer to chapter 10.5

7.14 Installation beneath a concrete slab

AS 2870-2011 "Residential slabs and footings" requires cold water pipes and heated or hot water pipes installed under a slab to be installed within a conduit so that if the pipe leaks water it will be noticed above the slab or outside the slab and will not leak unnoticed under the slab.

7.15 Exposure to excessive heat

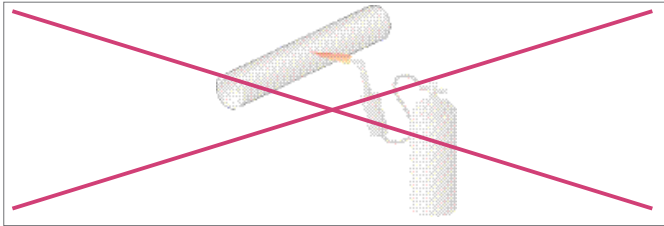

Fig. 7-34 Protect piping against exposure to excessive heat

During construction, maintenance or repair work in close proximity to heat care must be taken not to expose RAUTITAN pipe systems to a naked flame (soldering), flood lights or other localised heat sources. This can result in permanent damage or a significant reduction in performance life.

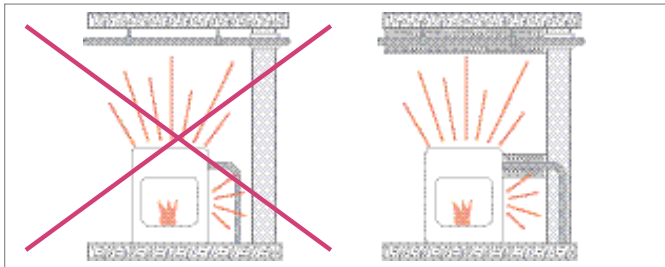

Fig. 7-35 Protection against temperature-induced stress

Piping close to devices with high temperature emissions must be insulated sufficiently and permanently protected against inadmissible heating.

Adhere to the maximum allowable operating parameters (e.g. operating temperature, pressure and duration).

7.16 Aligning fittings

Do not subject fittings and compression sleeves to plastic deformation, e.g. by hammer blows

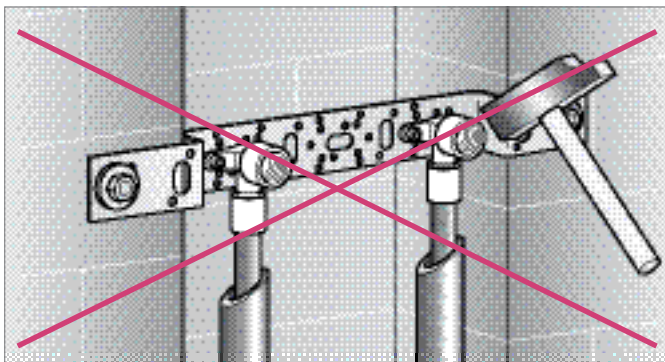

Fig. 7-36 Do not align using a hammer

Only align fitting with suitable tools, e.g. pipe nipples or open-end wrenches.

7.17 Heat trace

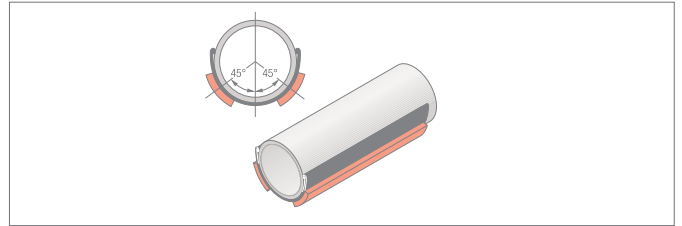

Fig. 7-37 Example of trace heating fitted to RAUTITAN pipe with support channel

The use of heat trace on RAUTITAN pipes is permissible provided the heat trace temperature is limited to 70°C at any point.

In pipes installed with pipe support channel the heat trace must be attached to the outside of the pipe support channel.

Observe the installation manual of the auxiliary heating manufacturer and ensure that any tape used to fix the heat trace to the pipe is suitable for contact with RAUTITAN components.

7.18 Potential equalization

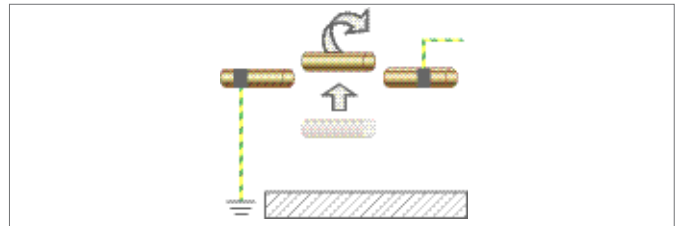

Fig. 7-38 Potential equalization while replacing pipes



RAUTITAN piping shall not be used as an earthing conductor.

After replacement of existing metal pipe installations with RAUTITAN system, the function of potential equalization and the effectiveness of the electrical safety devices must be verified by an electrician.

7.19 Installation in combination with bitumen sheets and coatings

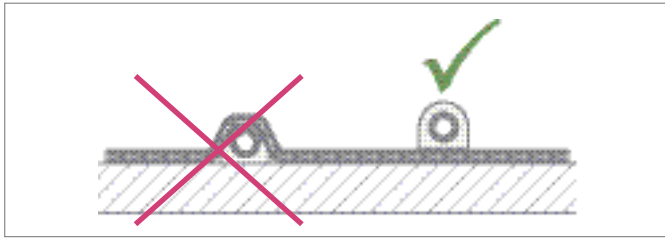

Fig. 7-39 Only install pipes on top of bitumen sheet

Do not lay pipes under bitumen sheeting. Laying under a bitumen sheeting can lead to damage to the piping or to the bitumen sheeting.

Allow the bitumen sheets or bituminous coatings that contain solvents to dry completely before installing the pipes. Adhere to the setting time specified by the manufacturer. Before laying the pipes, ensure that neither the pipes nor the drinking water are adversely affected. Protect the pipe adequately from heating while laying the pipes near flaming bitumen sheets.

7.20 Installation in areas with asphalt screed

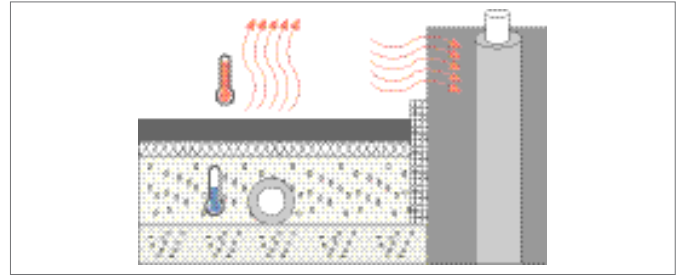

Fig. 7-40 Installation under hot asphalt screed

Hot asphalt screeds are laid at a temperature of approx. 250 °C. To protect the piping from overheating, proper steps need to be taken.

Since these depend on the structural conditions and cannot be influenced by REHAU, they must be coordinated with and approved by the planner.

- Do not lay RAUTITAN gas pipes under hot asphalt screed.
- Take the appropriate measures to ensure that RAUTITAN components (e.g. pipes, fittings, compression sleeves, joints) and pipe insulation do not at any point exceed 100 °C.



Consult with the contractor laying the hot asphalt screed and agree on suitable insulation and protective measures to prevent any damage to the pipes due to excessive heat.

08 Fire safety

The Building Codes of Australia and New Zealand both stipulate that service penetrations must not reduce the fire resistance level/rating of the building element they penetrate.

In Australia, the verification requirements for service penetrations are specified in the National Construction Code (NCC) Vol. 1 under Specification C 3.15 "Penetrations of walls, floors and ceilings by services".

The approved Document for New Zealand Building Code Fire Safety Clause C lists - under Paragraph 6.17 and Appendix C 6.1 - the requirement tests to prove a selected combination of the fire stop and pipe achieve the required fire resistance rating.

Applicable test methods are detailed in AS 1530.4 (methods for fire tests on building materials, components and structures – Part 4: Fire-resistant tests of elements of building construction).

Every service penetration reacts differently in the event of fire. As this is the case, test results are only applicable to the tested wall or floor construction, installed pipes and the applied fire stops. A fire safety engineer responsible for a particular building can at his discretion accept test results from a different test setup, if he deems the construction in question to be achieving a better fire rating than the one that was tested.

REHAU recommends to only use the fire protection methods which have been specifically tested with the RAUTITAN pipe system. REHAU cannot accept responsibility or liability for the correct manufacture or installation of fire protection systems.



- When planning and assembling fireproof collars, the requirements of the general building construction approval and the specifications of the assembly instructions must be observed.
- When using fireproof collars, the applicable national regulations must be observed.

Approved fire collar solutions for RAUTITAN systems are available from the following manufacturers.

- Promat
(1800 PROMAT or 1800 776 628 or www.promat.com.au)

- Snap
(1300 76 46 26 or www.snapcollars.com.au)

- Hilti
(131 292 or www.hilti.com.au)

Contact the manufacturer of the fire collar for information on fire test results and assembly/installation instructions to determine which solution suits your requirements.



RAUTITAN WATER SERVICES

09 Specific guidelines for water application

9.1 Standards and guidelines



RAUTITAN system for water services must be planned, calculated, installed and operated according to AS/NZS 3500 and other relevant standards.

9.2 Operating parameters

For continuous operation, the following parameters must not be exceeded.

Application: Hot water supply at 70°C / 1 MPa (10 bar)
(Application class 1-2 acc. ISO 10508)

The above continuous operating parameters are based on a life span of 50 years and allow for short periods of higher temperatures as listed in the following table:

Design temperature T_D	/ Time T_D	70°C / 49 years
Short-term maximal temperature T_{max}	/ Time T_{max}	+ 80°C / 1 year
Short-term malfunction temperature T_{mal}	/ Time T_{mal}	+ 95°C / 100 h
Total		= 50 years

Tab. 9-1 Operating parameters according to DIN EN 806-2, DIN 1988-200 and ISO 10508 (Application classes 1 and 2)

9.3 Drinking water requirements

The drinking water must comply with the currently valid limits of the following standards:

- Australian Drinking Water Guideline
- Drinking-water standards for New Zealand

The maximum disinfection agent concentration mentioned in above guidelines shall only be applied during temporary disinfection and not continuously. Refer to chapter 9.4.

In locations with highly corrosive water composition, e.g. in volcanic areas, installations using bore/well water etc., the suitability of RAUTITAN pipe system must be checked with REHAU. In some cases, the available water quality may void the REHAU warranty unless appropriate water treatment is provided.



RAUTITAN MX fittings are made of dezincification-resistant (DZR) brass and comply to AS 2345, DIN EN 1254-3, DIN EN 12164, DIN EN 12165 and DIN EN 12168.

RAUTITAN RX+ fittings are made of gunmetal and therefore especially corrosion resistant.

Nonetheless, no material does exist that can be used for every application.

In some specific cases, even drinking water qualities within the permitted range of the drinking water guideline and standards have properties that may negatively affect DZR brass fittings and lead to corrosion.

Water chemistry limitations

High levels of chloride contents combined with low levels of hydrogen carbonate contents may negatively influence the corrosiveness of the drinking water and lead to dezincification of DZR brass materials.

To avoid corrosion of RAUTITAN MX and RAUTITAN ONE fittings in drinking water application, the following limits shall not be exceeded:

- Chloride contents (Cl-) ≤ 200 mg/l
- Sulphate content (SO₄²⁻) ≤ 240 mg/l
- Calculated calcite solubility capacity ≤ 5 mg/l
(achieved as soon as pH value ≥ 7.7)



Treated drinking water (e.g. softened water) may be corrosive to RAUTITAN components.

- Verify supplied water from the treatment plant suits to all materials used in RAUTITAN water installation system.
- REHAU explicitly recommends to consult an expert or the system manufacturer for an assessment of the individual situation and to ensure correct design, installation and operation of water treatment plants. It is the responsibility of the system designer to ensure that the above-mentioned factors and parameters are taken into account to prevent corrosion and scaling. If the drinking water quality is outside the limits of the drinking water guidelines or above limits or if previous experience indicates corrosive tendencies of the supplied water, consult REHAU before using RAUTITAN system.

9.4 Disinfection of water services

REHAU pipes intended for drinking water together with the compression sleeve jointing technique without O-ring help to keep the hygiene level of drinking water installation. They correspond to the KTW guidelines of the German Federal Environment Agency and satisfy the requirements of the DVGW worksheet W 270. Thus, they are suitable for fields of application with special hygiene requirements when it comes to drinking water. It has been proven that RAUTITAN pipes for water services and heating installation do not cause any multiplication of micro-organisms and thus do not support microbial contamination or legionella growth.

Due to **errors made during planning, construction and operation, during stagnation or substandard water quality** (e.g. wastewater, floodwater, maintenance works on the piping network) contamination can occur. Furthermore, damage to the piping network, e.g. a supply line with external water inflow, can be the cause of possible contamination.

The disinfection of drinking water installation is only necessary in exceptional cases (in the case of contamination) and all operational and structural engineered system deficiencies are to be rectified first.

Repeated or constant bacterial exposure of domestic water installation is often caused by the installation method (e.g. stubs) or by the operation method (e.g. long stagnation periods), as such that continuous disinfection is not justifiable.

9.4.1 Thermal disinfection in case of contamination

For drinking water installations in compliance with the latest technical standards (no stubs, etc.), removal of dirt can be done by thorough water rinsing as long as the dirt is water-soluble or remains soluble in water.

If contamination is suspected, an additional thermal disinfection as per DVGW worksheet W 551 is possible as a sensible and urgent measure. According to the latest technological standards, for water with temperature of at least 70°C, it is very likely that germs and bacteria, including legionella which is found freely in water will be killed off. It is important that the appropriate measures have to be taken to avoid scalding to people.

All RAUTITAN piping system for water services and heating installation are suitable for multiple thermal disinfections according to DVGW worksheet W 551 at 70°C. It must be ensured that the allowable operating pressure is not exceeded during thermal disinfection.

9.4.2 Chemical disinfection in the case of contamination

Alongside with thermal disinfection, chemical disinfection is being used more and more. Chemical and thermal disinfection measures always strain the materials used in water services installation. According to today's level of awareness, some disinfection measures are not suitable for standard materials in installation technology. This also applies to materials, for which it was previously assumed that they were sufficiently corrosion-resistant, e.g. stainless steel, copper and some synthetic materials.

Before introducing these types of process measures, it needs to be ensured that all parts of the installation system are thermally and chemically suited for the corresponding measure. This is regulated by DVGW

worksheet 551. If necessary, please have the suitability of the disinfectant approved by the disinfectant's manufacturer for all system parts of the installation.

9.4.3 Chemical "Postrinse disinfection"

For short-term chemical disinfection (postrinse disinfections), only special active ingredients may be used which are specified in corresponding rules and standards.

Carrying out the disinfection measures according to the specifications of DVGW worksheet W 291 can be done without impairing the functionality of REHAU drinking water installation if the active ingredients, concentrations, application duration and maximum temperatures are observed (as listed in Table 9-2)

It should be noted that combining thermal-chemical disinfection at temperatures of higher than 25°C, as well as permanent or regular disinfection cycles (e.g. monthly), are not permitted. In relation to the lifespan of the piping, the total number of disinfection cycles is limited to five "postrinse disinfections". Otherwise, it cannot be guaranteed that the specified lifespan will be reached.

The person carrying this out must guarantee that the water is not used for human consumption (e.g. as drinking water) at any time during the disinfection phase, including the subsequent rinsing phase.

Description	Commercial size and packing	Storage	Safety advice ¹⁾	Max application concentration ²⁾
				Application duration and temperature in the piping
Hydrogen peroxide H₂O₂	Hydrous solution with maximum 150g/l chlorine	Light-protected, cool, avoid contamination at all costs	With >5% solutions, protective equipment necessary	150 mg/l H ₂ O ₂ Max. 24h T _{max} ≤ 25°C
Sodium hypochlorite NaOCl	Hydrous solution with maximum 150g/l chlorine	Light-protected, cool, sealed and in a collecting reservoir	Alkaline, corrosive, toxic, protective equipment necessary	50 mg/l chlorine Max. 12h T _{max} ≤ 25°C
Chlorine dioxide ClO₂	Two components (Sodium chloride, sodium peroxide sulphate)	Light-protected, cool and sealed	Oxidizing effect, do not inhale chlorine dioxide, protective equipment necessary	6 mg/l ClO ₂ Max. 12h T _{max} ≤ 25°C

Tab. 9-2 Chemical postrinse disinfections, active ingredients and concentrations according to DVGW W 291

¹⁾ The corresponding notes in the safety data sheets of the manufacturer must be adhered to.

²⁾ REHAU approval: this value may not be exceeded at any stage of the entire application duration of the installation.

9.4.4 Continuous chemical disinfection

REHAU cannot recommend using indefinite chemical disinfection in domestic installation, especially as a preventive measure for legionella prophylaxis, due to the possible occurrence of material damages to installation components. We cannot provide any guarantees in these cases.

In some cases, it may be the case that chemical disinfection may be necessary for a long time, but finite period of time, until structural decontamination has been completed. These disinfection measures may only be carried out if the permitted method is used. The parameters listed in Table 9-3 must be monitored and documented for the full duration of the disinfection measure, immediately after the dosing point. If the active ingredients, concentrations, application durations and maximum temperatures as listed in Table 9-3 are adhered to, execution without impairing the functionality of REHAU drinking water installation is possible.

In all cases, the drinking water must comply with the currently valid limits of the following standards:

- Australian Drinking Water Guideline
- Drinking-water standards for New Zealand

Description ¹⁾	Application temperature in the piping	Max. application concentration ²⁾	Max application duration in the piping ³⁾
Chlorine Cl ₂	Max. 50°C	Max. 5 mg/l	continuously
	> 50°C	Consult REHAU	
Chlorine di-oxide ClO ₂	Max. 60°C	Max. 0.2 mg/l ClO ₂	4 months

Tab. 9-3 Chemical disinfection with finite period

- ¹⁾ The corresponding notes in the safety data sheets of the manufacturer must be adhered to.
- ²⁾ REHAU approval: this value may not be exceeded at any stage of the entire application duration of the installation.
- ³⁾ Maximum application duration is an accumulation over the 50 year lifespan

Operating pressure 600 kPa assumed for all conditions
The above values do not apply to other disinfectants, ie Chloramine etc.

In hot water application above 50°C, the maximum permissible concentration of free Chlorine depends on the operating conditions (temperature, usage pattern) and water quality (pH value, ORP). Consult REHAU for advice.

Contact your local REHAU office for advise on operating conditions other than outlined above.

We generally exclude other non-listed disinfectant from being used, especially strong oxidants (e.g. ozone).



Chemical and thermal disinfection procedures when carried out incorrectly can lead to permanent damage to drinking water installation components.

Prior to commencing any such procedures, it needs to be ensured that all parts of the installation system are thermally and chemically suitable for the corresponding measure. If necessary, please have this approved by the disinfectant's manufacturer.

With thermal disinfection, it is important that the appropriate measures be taken to ensure that people are not scalded.

When carrying out discontinuous chemical disinfection it must be guaranteed that water is not used for human consumption (e.g. as drinking water) at any time during the disinfection phase, including the subsequent flushing/rinsing phase.

The safety advice from the disinfectant manufacturers must be observed.

9.5 Thermal insulation

Thermal insulation requirements for hot and cold water services are specified in the National Construction Code NCC and in AS/NZS 3500.

In cold water applications, the likelihood of pipe damage due to freezing can be reduced. It is, however, not possible to prevent static water from freezing completely. For longer periods during which freezing is likely to occur, pump warm water periodically through the pipe system. Alternatively, the complete system could also be drained.

REHAU offers pre-insulated pipes with 13 mm concentric insulation to minimize heat loss in hot water applications.



Fig. 9-1 Pre-insulated pipe

Material:	Co-extruded PE-foam with moisture barrier PE layer, CFC free.
Thermal conductivity:	0.04 W/mK
R-value:	0.3
Spread of Flame Index:	5
Smoke Developed Index:	5
Suitable use:	installation in concealed areas in all types of building specified by BCA



Pre-insulated pipes are not suitable for exposed installation in fire-isolated areas.

9.6 Noise reduction

Acoustic properties of PE-Xa pipes:

Fraunhofer Institute for Structural Physics in Stuttgart conducted a study of the sound level differences of PE-Xa, copper and galvanized steel pipes. Three common pipe diameters were compared under identical conditions such as dynamic pressure and flow rate.

The report shows that PE-Xa pipes generated up to four times less noise (sound level difference LA = 12.7 dBA) than the metal pipes. A complete copy of the report is available on request.

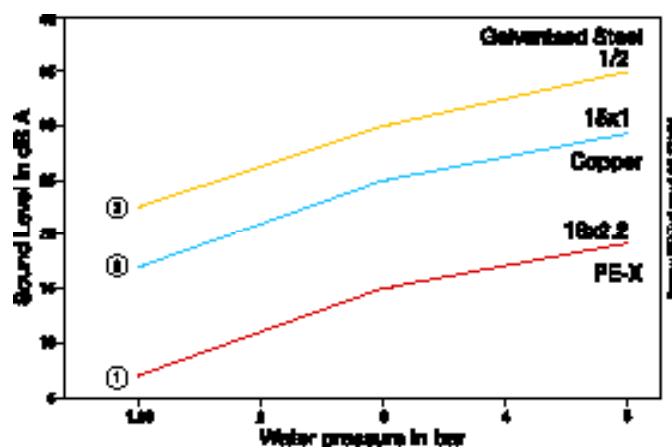

Fig. 9-2 Result of acoustics report from Acoustics Division of the Fraunhofer Institute of Structural Physics

Effects of water hammer:

The low elastic modulus of PE-Xa pipes and their ability to expand quickly and contract slowly enables the pipes to absorb water hammer effectively.

In cold water service installations, the water hammer effect can be reduced by up to 75% compared to metal pipe installations.

9.7 Water heater connection

REHAU recommends the installation of both isolation valve and non-return valve connected directly to the inlet of every water heater or with metallic piping between the valves and the water heater. REHAU recommends that the non-return valve be connected closest to the water heater and with the isolation valve at the up-stream of the non-return valve.

RAUTITAN platinum and RAUTITAN red system can be used for re-circulating hot water systems provided the operating temperature and pressure does not exceed the capabilities of the piping system.

9.7.1 Storage water heaters

All storage water heaters should be fitted with operational temperature and pressure relief valves for safety in the event of malfunction of the heater's operation. The rating of the temperature and pressure relief valve must be determined by the storage water heater manufacturer in terms of maximum temperature and pressure as required for the design and operational requirements of the water heater.

If the storage water heater does not have provision on the heater for fitting such a valve, REHAU recommends the installation of a temperature and pressure relief valve on the tee-connection of the heater's hot water outlet and its outlet piped to a drain location. This will allow the release of hot water during the heater's normal operation and in the event of safety operation of the valve. REHAU also recommends that the valve be operated manually every six months.



REHAU recommends that the outlet of storage water heaters be fitted with a minimum of 1 meter of metallic piping prior to the installation of RAUTITAN platinum or RAUTITAN red system.

9.7.2 Instantaneous water heater

Before connecting RAUTITAN piping system to either electric or gas fuelled instantaneous water heaters, the installer must check the appliance manufacturer's instructions regarding the connection of polymer pipes. The appliance operational temperature and pressure may exceed the capabilities of RAUTITAN piping and might cause failure of the piping system. Some manufacturers of instantaneous water heaters state that connection of their appliances to polymer piping systems is not suitable or subject to restrictions.

The installer must confirm with the appliance manufacturer that the maximum operational limits of the appliance will not exceed those of the piping system. REHAU recommends that only appliances with temperature control devices which can, at all times, restrict the outlet water temperature to within RAUTITAN piping system's capabilities, be installed in conjunction with RAUTITAN piping system.

9.7.3 Water heaters with uncontrolled energy sources

RAUTITAN platinum and RAUTITAN red pipes should not be used with uncontrolled energy sources and installation of a tempering valve is required.

9.7.4 Solar water heaters

As per AS/NZS 3500 requirement, polymer pipe systems must never be used on the flow and return piping to any solar panel.



Solar collectors and other uncontrolled heat sources generally have operating conditions which exceed those of RAUTITAN pipe system.

- Never use RAUTITAN pipes in the flow and return piping to any solar collectors/panels.
- Do not install RAUTITAN pipes in the flow and return of any uncontrolled heat source (e.g. wood fire heaters, etc.).
- If a heat storage tank is used, RAUTITAN pipes can be used after the tempering valve. Potential back siphoning of super heated water through the cold port of the tempering valve from cold feed to the uncontrolled heat source (including solar panels) must be prevented through adequate measures, e.g. fitting a suitable high temperature rated non-return valve between the cold feed to the solar panels and the tempering valve.

9.8 Rainwater application



Pipe identification

RAUTITAN green pipes are clearly identified as rainwater plumbing pipes by its special green outer coating and the marking "RAINWATER" as required by AS/NZS 3500 regulation.

System integration

For applications where rainwater is also used for drinking water, the local council or water authority may have imposed special restrictions regarding water treatment and compliance with the Australian Guidelines for Drinking Water. Conduct a careful check on the local requirements before contacting REHAU with regard to the suitability of RAUTITAN green for this application.

System installation

Installation must be carried out by a licensed plumber, adhering to the requirements of AS/NZS 3500 and that of the local water provider.

The installation of filters or screens on tank inlets and outlets is recommended to protect the appliances and the rainwater plumbing system from becoming clogged with sludge from sediments and organic materials.



Periodically check the pH level of tank water and ensure a pH level of 6.5 to 9 is maintained. This can be done by e.g. fitting a suitable inline filter system at the tank outlet.

Recommended hardness; 3-14° dH (53 - 250 ppm CaCO₃)

Do not add kerosene into the rainwater tank for mosquito control as this can have an adverse effect on your tank and the polymer piping.

System maintenance

Guidelines on rainwater tanks from your local authority should be observed.

Rainwater varies in its chemical composition with the geographical location and aggressive water can accelerate wear and tear on metal components of the system.

- Periodically check the pH level of tank water and ensure a pH level of 6.5 to 9 is maintained.
- Do not add kerosene into the rainwater tank for mosquito control as this can have an adverse effect on your tank and the polymer piping.

9.9 Recycled water application



Pipe identification

RAUTITAN lilac pipes are clearly identified as recycled water plumbing pipes by its special lilac outer coating and the marking "RECYCLED OR RECLAIMED - WATER - DO NOT DRINK" as required by AS/NZS 3500 regulation.

System installation

Installation must be carried out by a licensed plumber, adhering to the requirements of AS/NZS 3500 and that of the local water provider.

System limitations and water quality

The main application for RAUTITAN lilac plumbing systems are dual reticulation systems. Different states in Australia may have different guidelines for recycled water applications, adhere to the state-specific guidelines.

RAUTITAN lilac system shall only be used with highly treated recycled/reclaimed water (Class A and higher) and dual reticulation system. RAUTITAN lilac system is not suitable for use with Class B - D treated recycled/reclaimed water and direct untreated water reuse on domestic dwellings.

Typical applications for Class A recycled/reclaimed water are:

- Residential (non-potable)
 - Garden watering
 - Toilet flushing
 - Car washing
- Irrigation food crops to be consumed raw
- Municipal with uncontrolled public access
- Primary contact recreation

Corrosive water can accelerate wear and tear on metal components of the system. Refer to chapter 9.3 and 9.4 for specific water quality requirements to prevent corrosion in RAUTITAN system.

In some cases, the available water quality may void the REHAU warranty unless appropriate water treatment is provided.

9.10 Water services flushing and pressure test

9.10.1 Flushing and pressure test

A visual check shall be carried out prior to pressure testing to ensure all compression sleeve joints have been secured completely.

Flushing of the system shall occur prior to and after pressure testing.

Flushing and pressure testing may be conducted in accordance with AS/NZS 3500, or by following the REHAU recommendations below.



The successful execution and documentation of a pressure test is a prerequisite for any warranty claims from REHAU.

Notes

The temperature difference between the pipe and test medium may influence the pressure test and may give false readings. A temperature change of 10°C corresponds approximately to a pressure change of 0.5 to 1 bar (50 to 100 kPa). For this reason, every effort should be made to ensure that the temperature of the test medium remains constant during the pressure test.

In this context, it is important to carry out a visual inspection of all joints while the pressure test is in progress, since experience has shown that minor leakages cannot always be detected simply by monitoring the pressure gauge.

9.10.2 REHAU Pressure test with water

The REHAU recommended pressure test procedure is an alternative solution to the requirements as described in AS/NZS 3500.

General requirements and notes:

- Conduct the pressure test on the completed but not yet concealed piping before commissioning.
- During pressure test, conduct a visual check of all unconcealed pipe work as the system's leak-tightness can't be derived from the pressure fluctuation (constant, decreasing, increasing) alone.
- Subdividing the piping system into smaller test sections may increase the test accuracy.

Preparation

1. Piping shall be accessible and not be concealed.
2. Dismount safety devices and meters as necessary and replace with pipes or pipe stoppers.
3. Fill the piping system from the lowest point with filtered drinking water and purge all air. Ensure all outlets are closed.
4. Connect the pressure testing equipment at the lowest point on the drinking water installation. The measurement precision shall be 100 hPa (0.1 bar) or better.
5. During pressure test, ensure temperature fluctuations are kept to a minimum.

Pressure test for installations with RAUTITAN stabil pipes

RAUTITAN stabil

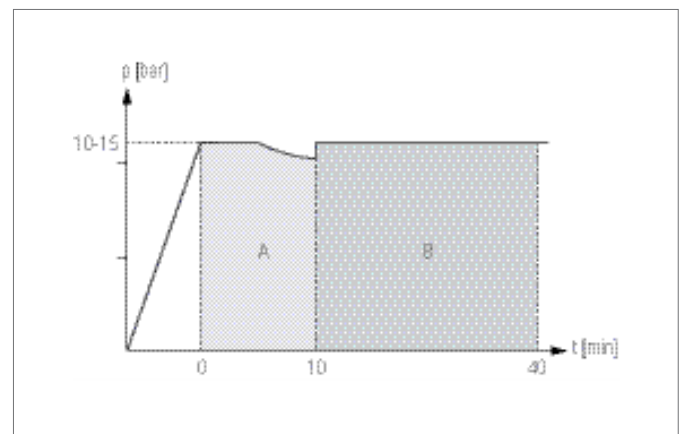

Fig. 9-3 Pressure test diagram for RAUTITAN stabil
 A Adaptation time (if necessary restore the pressure)
 B Pressure test for installations with RAUTITAN stabil and installations with RAUTITAN stabil pipes mixed with metal pipes

1. Determine an initial test pressure "X" between 10 and 15 bar (1,000 - 1,500 kPa).
2. Slowly build up test pressure to "X" bar.
3. If the difference between ambient temperature and water temperature is greater than 10°C, wait 30 minutes to adjust.
4. Check the test pressure after 10 minutes and adjust it back to the initial test pressure "X" if necessary.
5. During testing, perform a visual check on all joints and pipe work for leaks.
6. Record pressure in the piping system after a test period of 30 minutes.

If the test pressure has fallen:

- Repeat visual inspection of the installation, outlets and joints.
- After resolving the cause of pressure loss, repeat steps 1 - 5.

7. Pressure test ends once no leaks are detected during visual inspection.

Pressure test for installations with RAUTITAN PE-Xa pipes

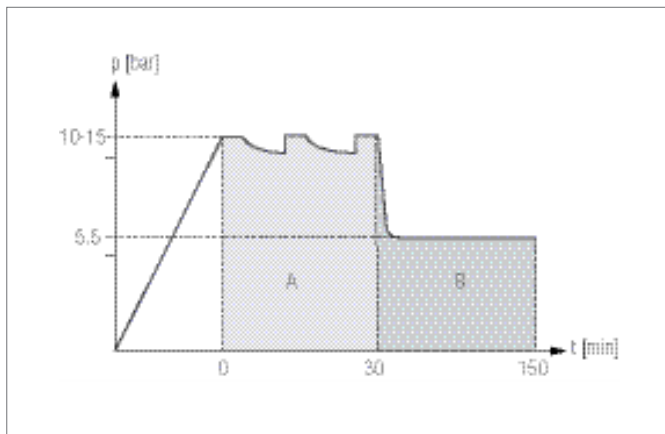

Fig. 9-4 Pressure test diagram

- A Adaptation time (if necessary restore the pressure)
 B Pressure test for installations with RAUTITAN PE-Xa and installations with RAUTITAN PE-Xa pipes mixed with metal pipes

1. Determine an initial test pressure "X" between 10 and 15 bar (1,000 - 1,500 kPa).
2. Slowly build up test pressure to "X" bar.
3. Maintain initial test pressure "X" during the 30 minute adjustment period.
4. Perform a initial visual inspection on all joints and pipe work for leaks.
5. Slowly decrease the test pressure from the initial test pressure "X" bar to 5.5 bar (500 kPa).
6. Perform a second visual check.
7. Record pressure in the piping system after a test period of 2 hours.

If test pressure has fallen:

- Repeat visual inspection of the installation, outlets and joints.
- After resolving the cause of the drop in pressure, repeat steps 1 - 6.

7. Pressure test ends once no leaks are detected during visual inspection.

Completion of REHAU pressure test with water

1. Fill and sign pressure test protocol, refer to Appendix A7.
2. Detach the pressure test equipment.
3. Thoroughly flush and empty the drinking water pipes for hygiene purposes (see chapter 9.10.4).
4. Reinstall all removed safety devices and meters.

In sub-zero conditions or if the drinking water installation is commissioned at a later stage, thoroughly drain all pipe work for hygienic reasons. Repeat flushing the pipe system before commissioning, or periodically if water stays in the pipe system for longer periods.

9.10.3 REHAU Pressure test with air

The REHAU recommended pressure test procedure is an alternative solution to the requirements as described in AS/NZS 3500.

Important information on tests with pressurised air and inert gas:

- Use only oil free pressurised air or inert gas.
- Small leaks may only be detected using leak detection agents at high test pressures (load test) and visual inspection.
- Temperature fluctuations may affect the test result (pressure loss or increase).
- Pressurised air and inert gas are compressed gases. This means that the piping volume has a lot of influence on the shown pressure result. A high piping volume reduces the determination of small leaks using pressure reduction.



Leak detection agents

Only use leak detection agents (e.g. foaming agents) with current DVGW certification, which are also approved by the respective manufacturers for PPSU and PVDF materials.

General requirements and notes:

- Conduct the pressure test on the completed but not yet concealed piping before commissioning.
- During pressure test, conduct a visual check of all unconcealed pipe work as the system's leak-tightness can't be derived from the pressure fluctuation (constant, decreasing, increasing) alone.
- Subdividing the piping system into smaller test sections may increase the test accuracy.

Preparation

1. Piping shall be accessible and not be concealed.
2. Dismount safety devices and meters as necessary and replace with pipes or pipe stoppers.
3. Install air purges in appropriated locations to allow a safe drain after completion of the test. Ensure all outlets are closed.
4. Connect the pressure testing equipment. The measurement precision shall be 1 hPa (1 mbar) or better.
5. During pressure test, ensure temperature fluctuations are kept to a minimum.

Pressure test with air step 1 – leak test

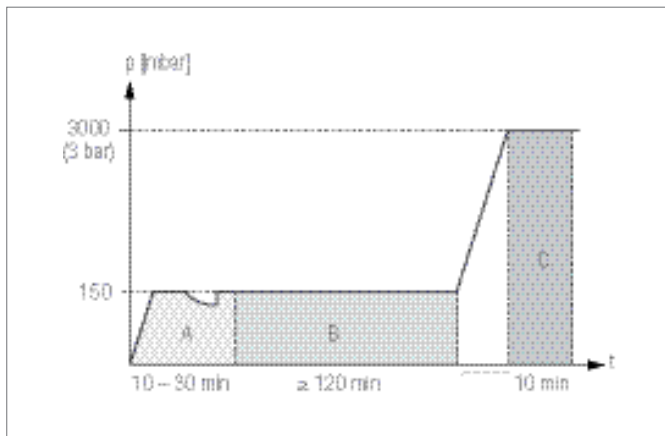

Fig. 9-5 Pressure test diagram for with pressure air or inert gas

- A Adaptation time, see table below
 B Leak test
 C Load test

Pipe volume	Adaption time ¹⁾	Test time ¹⁾
< 100 l	10 min	120 min
≥ 100 < 200 l	30 min	140 min
≥ 200 l	60 min	+ 20 min per 100 l

1) Approximate values, depending on the piping volume

Tab 9-4 Pipe volume, adaptation time and test time

- Slowly build up the test pressure to 150 mbar in the piping system.
- Let the adaptation time (refer to Tab. 9-4) pass.
If necessary restore the test pressure.
- During the pressure test, perform a visual check on all joints and pipe work using a suitable leak detection agent
- Record pressure in the piping system after the test time (refer to Tab. 9-4).
If the test pressure has fallen:
 - Repeat visual inspection of the installation, outlets and joints.
 - After resolving the cause of the drop in pressure, repeat steps 1 - 5.
- Pressure test is complete once the visual inspection confirms no leaks.
- Test protocol is found in Appendix A8.

Pressure test with air step 2 – load test

- Slowly build up the test pressure to 3 bar (300 kPa) in the piping system.
- If necessary, restore the test pressure after the pressure has stabilised.
- During the pressure test, perform a visual check of all joints and pipe work using a suitable leak detection agent

- Record pressure in the piping system after 10 minutes.
If the test pressure has fallen:
 - Repeat visual inspection of the installation, outlets and joints.
 - After resolving the cause of the drop in pressure, repeat steps 1 - 5.
- Pressure test is complete once the visual inspection confirms no leaks.
- Test protocol is found in Appendix A8.
- Securely drain the air out of the pipe system.

Completion of REHAU pressure test with air

- Fill and sign pressure test protocol in Appendix A8.
- Detach the pressure test equipment.
- Thoroughly flush and empty the drinking water pipes for hygiene purposes (see chapter 9.10.4).
- Reinstall all removed safety devices and meters.

In sub-zero conditions or if the drinking water installation is commissioned at a later stage, thoroughly drain all pipe work for hygienic reasons. Repeat flushing the pipe system before commissioning, or periodically if water stays in the pipe system for longer periods.

9.10.4 Purging and commissioning

Before commissioning the drinking water system, dirt from the construction phase has to be flushed out:

- Open all outlets in sequential order and for several minutes.
- If purging with drinking water alone is not efficient or if coarse dirt is visible in the piping system, it is recommended to purge the system alternating with water and pressurised air for several minutes or until all dirt has been flushed out.
- If the drinking water system won't be operated immediately after commissioning, it is recommended to completely drain the drinking water lines for hygiene purpose. Purge the drained system thoroughly before recommissioning.
- If water has to stay in the piping a long time before the system is put into operation, purging of the installation has to be periodically repeated for hygiene reasons.
- In sub-zero conditions it is recommended to completely drain the drinking water lines to avoid freezing. Purge the drained system thoroughly before commissioning.

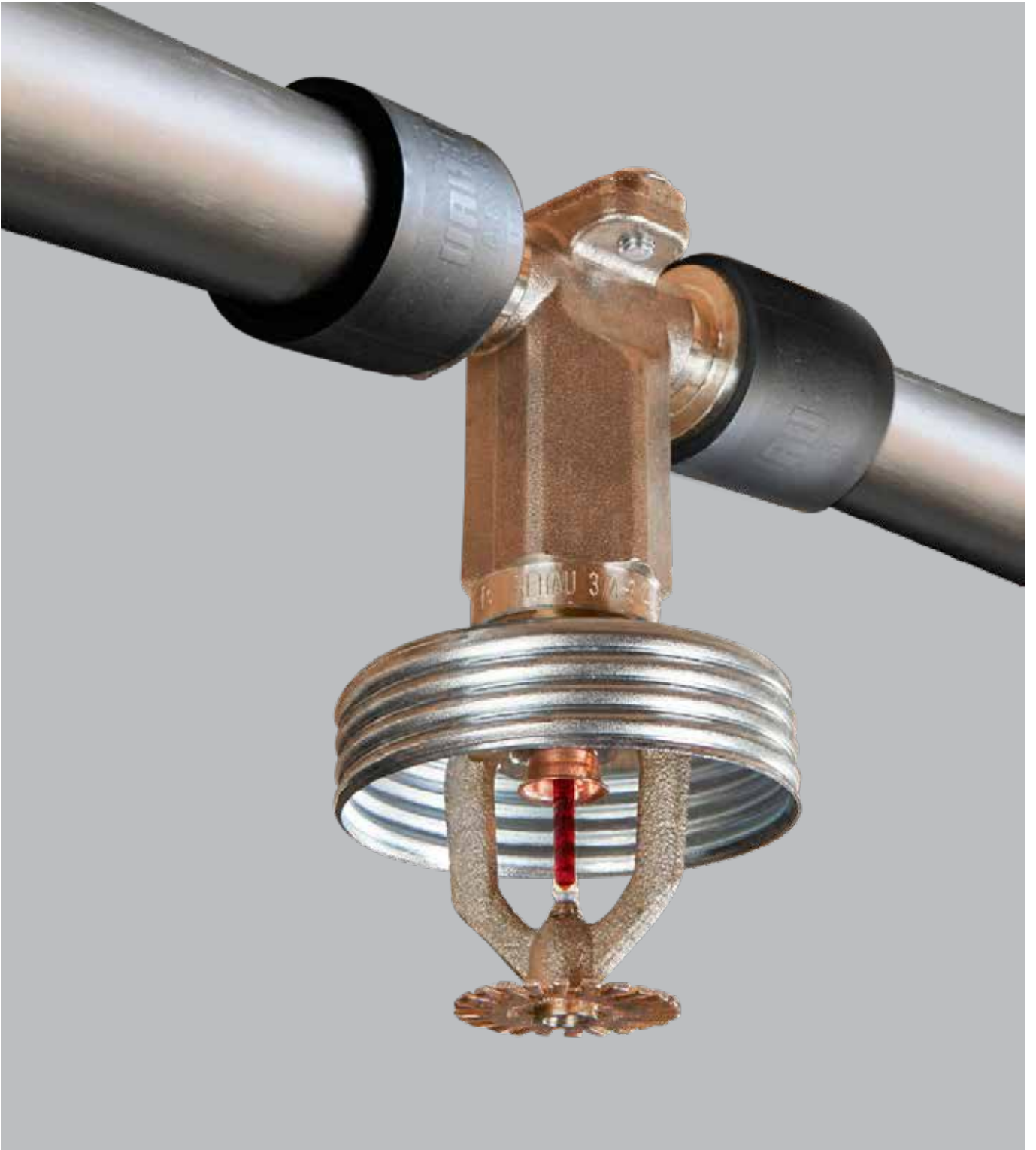

Fire Sprinkler

FIRE SPRINKLER

10 Specific guidelines for Fire Sprinkler application

10.1 Validity

This chapter is only applicable to Australia.

10.2 Standards and guidelines

NCC 2019 requires all new Class 2 and 3 residential buildings with a rise in storeys of four or more (and an effective height of 25 metres or less) to have automatic fire sprinklers installed under the Deemed-to-Satisfy (DTS) provisions.

The NCC references a new type of fire sprinkler system as defined by the standard FPAA101D. This type of system draws water from the drinking water supply of the residential building and as such, requires PE-X pipe and fittings to be Watermarked to AS 2492 and AS/NZS 2537 respectively.

10.3 RAUTITAN components and tools

REHAU RAUTITAN platinum and red pipe, as well as RAUTITAN PX/PXsr, MX, One, RX+ and EX+ fittings comply with the relevant requirements and are suitable for fire sprinkler systems as defined by the standard FPAA101D.

RAUTITAN stabil or RAUTITAN gas stabil pipe do not comply with the specific material requirements of FPAA101D and are not permitted for use in fire sprinkler systems.

For a list of suitable REHAU tools refer to the relevant chapter in this Technical Information.

10.4 Installation and operation

RAUTITAN system for fire sprinkler installation must be planned, calculated, installed and operated according to FPAA101D.



Only licenced plumbers or sprinkler installers that additionally have received training and authorisation from REHAU shall install RAUTITAN system for fire sprinkler application to FPAA101D. Refer to your local jurisdiction on licencing requirements in your state.

For REHAU training and authorisation refer to myREHAU.com.

The complete RAUTITAN system for fire sprinkler installation is designed for installation in new buildings, and for carrying out renovations and repairs. It is suitable for use as the fire sprinkler system throughout the entire Class 2 and 3 residential building with a rise in storeys of four or more (and an effective height of 25 metres or less). This includes some Class 2 and 3 residential buildings with partial non-residential use. For details refer to the NCC.

For general information on RAUTITAN components, transport, storage, making a joint, installing and fire safety of RAUTITAN pipes and fittings refer to the relevant chapters in this Technical Information.

10.4.1 Operating parameters

For continuous operation, the following parameters must not be exceeded.

Continuous operating temperature	Maximum 70°C (Maximum 90°C short term)
Continuous operating pressure	Maximum 1,000 kPa

Tab. 10-1 Parameters for continuous operation

10.4.2 System Identification

FPAA101D does not explicitly state requirements for identification of the sprinkler system.

Should a particular project require marking or pipe identification, we recommend that the marking / labelling be non-adhesive (e.g. no stickers etc.) and suitable for contact with PE-X material.



Fig 10-1 Example of pipe marking (external, not from REHAU)

10.5 Pressure testing and commissioning

A visual check shall be carried out prior to pressure testing to ensure all compression sleeve joints have been secured completely.



The successful execution and documentation of a pressure test is a prerequisite for any warranty claims from REHAU.

10.5.1 Commissioning Procedure

When RAUTITAN is installed in a system conforming to FPAA101D, to be in alignment with our commissioning procedure for fire systems, it is compulsory to completely flush the system and confirm flow at each sprinkler connection point. As such the complete RAUTITAN fire system procedure is as follows:

- a) Completely flush all supply piping before connection is made to the sprinkler piping.

In addition, completely flush the sprinkler piping network and confirm flow at each sprinkler connection point, prior to the connection of sprinklers.



When RAUTITAN is installed in a system conforming to FPAA101D, it is compulsory to completely flush the sprinkler piping and confirm flow at each sprinkler connection point.

- b) Test system piping hydrostatically at a pressure of 1,500kPa for not less than 30 minutes.

Notes

- i) Refer to chapter 9.10.2 for REHAU recommended pressure test procedure at test pressure "X" of 1,500 kPa (15 bar).
- ii) The temperature difference between the pipe and test medium may influence the pressure test and may give false readings. A temperature change of 10°C corresponds approximately to a pressure change of 0.5 to 1 bar (50 to 100 kPa). For this reason, every effort should be made to ensure that the temperature of the test medium remains constant during the pressure test.
- c) While the pressure test is in progress, carry out a visual inspection of all joints, since minor leakages cannot always be detected simply by monitoring the pressure gauge.
- d) Complete the commissioning procedure as per FPAA101D.





RAUTITAN GAS SERVICES

11 Specific guidelines for gas application

11.1 RAUTITAN gas connection components and tools

This Technical Information describes the components and requirements for the installation of RAUTITAN gas system using RAUTITAN ONE fittings and RAUTITAN PX polymer sleeves.

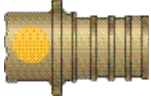
Components and assembly requirements for RAUTITAN gas system using RAUTITAN gas brass fittings and sleeves delivered as a SET are described in the respective sections of REHAU's Technical Informations "Piping, Connection and System Guidelines" (No. ANZ GT 0064.05.12 EN) and "RAUTITAN GAS Installation System" (No. ANZ 872 0281.10.09).

RAUTITAN gas connection components for gas installation			
Size	Pipes	Fittings	Compression sleeves
16			
20			
25			
32	RAUTITAN gas stabil gas pipe	RAUTITAN ONE fitting with yellow marking	RAUTITAN PX compression sleeve
40			

Tab. 11-1 RAUTITAN gas connection components

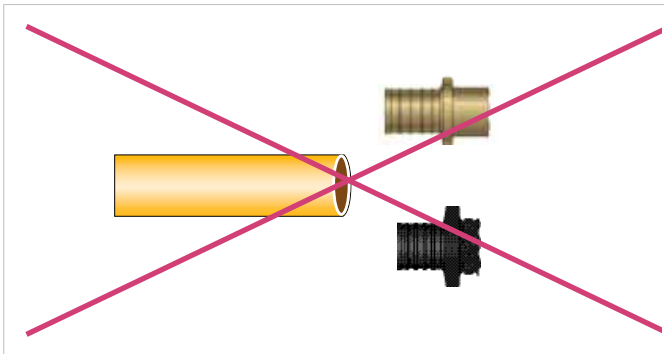

Fig. 11-1 Unapproved RAUTITAN gas connection components



Don't use RAUTITAN PX / PXsr fittings, gunmetal fittings or brass fittings without yellow marking in gas installation.

RAUTITAN Gas stabil	RAUTITAN gas stabil	Pipe dimensions				
		16	20	25	32	40
Pipe cutters:						
Pipe cutter 16/20 (stabil)		+	+	-	-	-
Pipe cutter 40		-	-	+	+	+
Expander heads:						
Expander head with green rings and tapered end		+	+	+	+	-
Expander bit (green) with tapered end		-	-	-	-	+

Tab. 11-2 Pipe cutters and Expander heads for installation of RAUTITAN gas system

11.2 Standards and guidelines

§ RAUTITAN gas system for gas installation system must be planned, calculated, installed and operated according to AS/NZS 5601.1.

RAUTITAN gas system

RAUTITAN gas system must be installed according to AS/NZS 5601.1. It can be used for supply of Natural Gas (NG) and Liquefied Petroleum Gas (LPG) with normal operating temperature of 60°C and can also temporarily withstand temperature of up to 90°C.

The complete RAUTITAN gas system is designed for installation in new buildings, and for carrying out renovations and repairs. It is suitable for gas installation systems in buildings for residential, industrial and commercial use such as hospitals, schools, kindergartens, sports halls, churches, aged care facilities, supermarkets and services stations, as well as industrial premises, etc.

§ RAUTITAN gas stabil pipe must not be used for drinking water or heating installations.

11.3 Operating parameters

For continuous operation, the following parameters must not be exceeded.

Continuous operating temperature	Maximum 60°C (Maximum 90°C short term)
Continuous operating pressure	Maximum 70 kPa
Minimum designed service life	50 years

Tab. 11-3 Parameters for continuous operation

11.4 System accessories

11.4.1 RAUGUARD protective conduit

§ According to national gas installation standards, gas consumer piping must not be located where physical damage to the pipe is likely to occur, unless adequate protection is provided. Such damage can be caused, among other things, from rodents or other vermin.

⚠ If RAUTITAN gas stabil pipe is used in a location accessible to rodent or vermin (e.g. wall cavities, roof spaces, sub-floor cavities or ducts where the pipes are not fully embedded into concrete), RAUGUARD flexible metal conduit should be fitted over the pipe to protect from gas leaks.



Fig.11-2 RAUGUARD flexible metal conduit

- ✓ RAUGUARD provides adequate protection to RAUTITAN gas stabil pipes against:
- Vermin attack
 - Mechanical damage through nails, hammer, etc
 - UV radiation

RAUGUARD is available in five sizes:

Description	REHAU pipe size OD x s
RAUGUARD 16/20	16.2 x 2.6 20 x 2.9
RAUGUARD 25	25 x 3.7
RAUGUARD 32	32 x 4.7
RAUGUARD 40	40 x 6.0
RAUGUARD 40+	40 x 6.0

Tab. 11-4 Available RAUGUARD sizes and respective RAUTITAN gas stabil pipe sizes

- RAUGUARD protective conduit is not gas-tight and cannot be used for discharging gas from unvented into vented areas or to the outside of a building.
- RAUGUARD protective conduit is zinc plated to protect against corrosion, under normal operating conditions. Permanent or reoccurring exposure to corrosive environments or chemicals or any liquids can cause permanent damage to the conduit compromising the protective function.

11.4.2 Protective conduit (PE)

For protection against most chemical and mechanical damages other than vermin attack, a yellow protective conduit (PE) can be used for the gas pipe RAUTITAN gas stabil.

11.5 Installation of RAUTITAN gas system

11.5.1 REHAU Authorised Installer



Only licenced gas fitters that additionally have received training and authorisation from REHAU shall install RAUTITAN gas system. Authorisation is obtained through attendance of a REHAU organized training session and successful completion of a written test.

Upon completing the REHAU training session and written test, authorised installers will be registered on myREHAU database and can download their training certificate.

Installers should be aware that a verification process is in place at the point of sale and that they may be asked to present their authorisation certificate before the transaction is processed.

11.5.2 Gas installation requirements

This chapter outlines specific guidelines and requirements for the installation of RAUTITAN gas system in addition to the general installation requirements as outlined in chapter 7.

They shall not be interpreted as substitution or negation of the requirements set out in AS/NZS 5601.1.



AS/NZS 5601.1 sets out the requirements for installing consumer gas piping in Australia and New Zealand and shall be observed at all time. Gas consumer piping shall not be located where physical damage to the pipe is likely to occur, unless adequate protection is provided. Such damage can be caused, among other things, through rodents or vermin. The system needs to be designed and installed in such a way that damages caused by corrosion, stress and other means are avoided.

If RAUTITAN gas stabil pipe is used in a location accessible to rodent or vermin (e.g. wall cavities, roof spaces, sub-floor cavities or ducts where the pipes are not fully embedded into concrete) RAUGUARD flexible metal conduit should be fitted to protect the pipe from damage. Refer to Appendix A2 to learn how to use RAUGUARD.



RAUTITAN gas stabil pipe and fittings must not be subjected to mechanical, physical or chemical damage.

Select the type of protection depending on specific site conditions and the intended building use, e.g.:

- System connection to isolating valve of an oven or heater which could be exposed to aggressive cleaning agents, cooking oils, greases, etc.
- Exposed components which may get painted on by end users.

Use either RAUGUARD or the yellow REHAU protective conduit as appropriate.

Installation in wooden joists or steel frames

Avoid holes and notches in wooden joists wherever possible. If crossing wooden joists or steel frames:

- Adequately size pipe penetrations in wooden joists or steel frames.
- Use pipe grommets or similar to protect the pipe from damage.



Damages to the outer PE layer of RAUTITAN gas stabil may cause corrosion to the Aluminium layer and compromise the integrity of the joint.

Concealed locations - cavities, roof spaces and suspended floors

Consider the potential mechanical damages caused by trades or later by building occupants (power drills, staplers, nail guns and similar tools) and install the pipes accordingly to prevent such damage, e.g. through

- Sufficient clearance between the gas pipes and finished wall/floor/ceiling surface.
- Application of a protective conduit.
- Application of RAUGUARD metal conduit if the location is accessible to vermin.
- Minimize the number of joints used in unvented areas.



RAUTITAN gas system joints are classified as permanent joints in accordance with AS/NZS 5601.1.

Embedded in concrete – walls or slabs

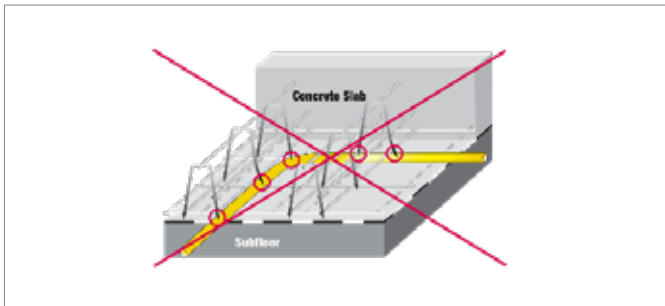

Ensure that no sharp-edged steel parts or equivalent can damage the pipe when installing RAUTITAN gas stabil in concrete walls or floors or in between concrete reinforcement.

- Protect the pipe from sharp edges and stones.
- AS/NZS 5601.1 allows no fittings or joints for pipe embedded in concrete.

Below ground beneath a building:

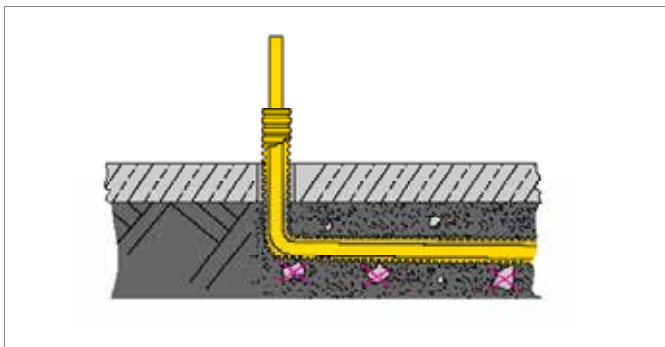

Fig. 11-4 Protection of RAUTITAN gas stabil pipes below ground beneath a building

Ensure that no sharp-edged steel parts or any shattering can damage the RAUTITAN gas stabil pipe when installed in ground beneath a building:

- Use conduit to protect RAUTITAN gas stabil pipe from sharp edges and stones.
- AS/NZS 5601.1 allows no fittings or joints for pipe installed below ground beneath buildings.

External below ground

Refer to chapter 7.13 for details on installation and protection of pipes and fittings installed below ground.

- Minimize the number of joints.
- Adequately protect fittings to prevent corrosion.

External above ground

RAUTITAN gas system shall in general not be installed above ground, except for the following:

- Short pipe length after connection to gas meter before going in ground
- Connection to an external gas appliance above ground
- Connection to an above ground LPG tank

The length of pipe installed above ground shall be kept to an absolute minimum not exceeding 2 metres. Below ground installation should always be preferred.

RAUTITAN gas stabil pipe shall not be used to support the gas meter. Use an appropriate support frame and brackets to support the gas meter.

Refer to chapter 7.12 for details on installation and protection of pipes and fittings installed above ground.

Installation in areas prone to vermin

If RAUTITAN gas stabil pipe is used in a location accessible to rodent or vermin (e.g. wall cavities, roof spaces, sub-floor cavities or ducts where the pipes are not fully embedded into concrete) then the protective conduit RAUGUARD should be fitted over the pipe. Failure to fit the protective conduit RAUGUARD in these circumstances could result in rodents or vermin gnawing through the pipe and a gas leak.



- RAUGUARD protective conduit should be used in areas prone to vermin.
- RAUGUARD protective conduit is not gas-tight and cannot be used for discharging gas from unvented into vented areas or to the outside of a building. If used in such a way, gas can leak through the conduit.
- RAUGUARD protective conduit is zinc plated to protect against corrosion, ensuring a safe, reliable and long lasting performance under normal operating conditions. Permanent or reoccurring exposure to corrosive environments or chemicals or any liquids can cause permanent damage to the conduit. If such permanent damage occurs, the protective function of RAUGUARD for RAUTITAN gas stabil, e.g. against vermin, is compromised. This can result in gas leak due to vermin attack or through other physical damage.

More detailed information on how to install RAUGUARD can be found in Appendix A2.

Using No.19BP wall elbows with parallel thread:

Where no practical alternative is available, AS/NZS 5601.1 allows connections between a running nipple with external parallel thread (male) to internal parallel threads (female). Connections with tapered threads in accordance with ISO 7-1 shall be preferred.

When jointing RAUTITAN ONE No.19BP wall elbow with external parallel thread (male) to an internal parallel thread (female), the installation must comply with the requirements of AS/NZS 5601.1 Clause 4.4. - Either the joint is welded before RAUTITAN gas pipe is connected to the fitting, or a suitable certified quick-setting thread compound has to be used.

Reversion fittings



AS/NZS 5601.1 includes specific requirements for the installation of reversion fittings in multiple appliance installations Class I buildings in Australia or detached or multi-unit dwellings in New Zealand where the pipe main run exceeds 10m in length.

Reversion to a standard thread complying to ISO 7-1 (BSPT) or a standard annealed copper tube shall be provided at both the following accessible locations:

- a) In the main run immediately prior to the first branch take off point,
- b) In the main run immediately prior to the last branch take off point.

System Identification label

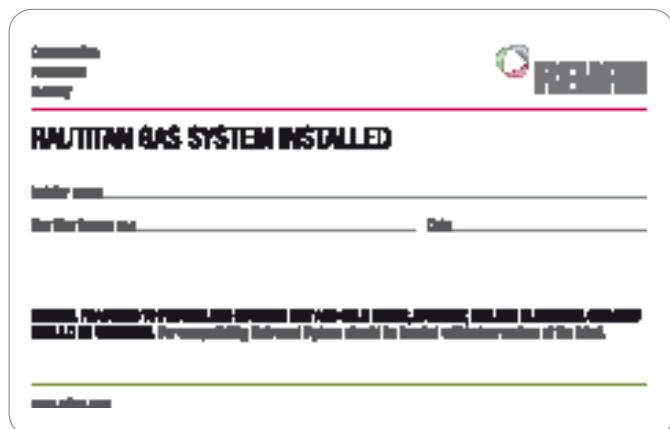

Fig. 11-5 REHAU system ID label



AS/NZS 5601.1 requires the gas fitter to fit an identification label close to the meter box or at an accessible location to identify the installed gas pipe system.



Different brands of composite gas pipe systems are not dimensionally compatible. Fittings and tools from one brand cannot be safely used on another brand. The system identification label clearly identifies the installed system preventing an accidental mix-up of components.

- Attach the REHAU system identification label on every installation adjacent to the gas meter or gas bottle (not on the meter or bottles themselves as these may get replaced!).
- Complete each label with the required information using a permanent pen or marker.

11.5.3 Prohibited locations

REHAU explicitly prohibits the installation of its RAUTITAN gas system in any of the following areas:

- In emergency escape routes and emergency stairways and corridors
- Space between emergency stairways and the outside
- Lift wells
- In clothes chutes or rubbish chutes
- In a fire hydrant or fire hose reel cabinet
- In a fire control room
- As a final connection to appliances
- Locations where pipes are permanently exposed to any liquids
- External installations exposed to UV-radiation
- Locations with unprotected pipes where UV exposure is likely

Check with your local building regulatory authority for further restrictions.

11.6 Pressure testing RAUTITAN gas system

Pressure testing shall be carried out in accordance to the procedures specified in the respective gas installation standards in Australia and New Zealand.

Installation and commissioning of RAUTITAN gas stabil installations shall only be carried out by licensed gas fitters or persons licensed / authorized by the gas network operator, who are also registered and authorized RAUTITAN gas installers.

The pressure tests and associated procedures as described in the respective gas installation standards are compulsory for the RAUTITAN gas system.

A pressure test protocol can be found in Appendix A6



Leak detection agents

Only use leak detection agents (e.g. foaming agents) with current DVGW certification, which are also approved by the respective manufacturers for PPSU and PVDF materials.

12 Sizing RAUTITAN gas system

12.1 General



The RAUTITAN gas system shall be designed, calculated, installed and operated in accordance with the national gas installation standards.



When sizing new installations, foreseeable future extensions and needs should be taken into consideration.

Prior to connecting new appliances to an existing gas consumer piping, the existing pipework, gas meter and pressure regulator have to be checked for adequate capacity to accommodate the additional load.

Prior to pipe sizing, the following information must be obtained:

- The type of gas: LPG or NG.
- The gas consumption of each appliance (MJ/h).
- Diversity factor. An allowance to reduce the load where there is a probability that not all appliances will be used simultaneously.
- The available pressure at point of delivery (gas meter).
- The allowable pressure drop. The pressure drop shall be taken into consideration to ensure that the minimum pressure required by the appliance is available.
- The proposed layout of the consumer piping system, including all the pipe lengths and the location of each appliance.

12.2 Pipe sizing method

Gathering basic information

This first step of the gas pipe sizing method includes:

- Knowing the type of gas and the allowable pressure drop.
- Obtaining house floor plan with the intended gas appliance locations.
- Sketching the intended gas piping layout.
- Determining the length of each pipe section, i.e. from gas meter to first T-piece, from T-piece to the appliance, from T-piece to the next T-piece, etc.

Preliminary gas pipe sizing

This step is the first guess of the gas pipe diameter by considering only the length of each pipe section, excluding the gas fittings used in each pipe section. This step includes:

- Determining the load of each gas appliances in MJ/h.
- Calculating the required load for each pipe section.
- Identifying the preliminary Main Run, this is the longest pipe run from the gas meter to the farthest appliance.
- Selecting the gas pipe size based on the preliminary Main Run length by using the relevant gas tables available in Appendix A3 or A4. Select the column with the same or next greater length than the preliminary Main Run. This column will be used throughout the preliminary gas sizing step for all the pipe sections.

Adding Fitting's equivalent pipe length

RAUTITAN gas fittings can be classified into three different fitting types, each of the fitting type has different equivalent pipe length according to its size. This is to accommodate a better accuracy in sizing the gas pipe.

Based on the preliminary gas pipe sizing, select the relevant fitting's equivalent pipe length from Appendix A5 and add the values into each of the pipe section.

For T-piece fittings located within the main run but branching to the appliances, those fittings will have to be considered twice, once as a T-flow (in the main run pipe section) and another time as a T-branch (in the pipe section branching to the appliance).

Confirming the preliminary pipe sizing

This last step of pipe sizing takes into account the gas fittings installed in each pipe section. This last step includes:

- Establishing the total equivalent pipe length for each pipe sizing (including the pipe length and the fittings' equivalent pipe length).
- Identifying the Final Main Run. The Final Main Run may include different pipe sections compared to the Preliminary Main Run.
- Selecting the gas pipe size based on the Final Main Run length by using the relevant gas tables available in Appendix A3 or A4. Select the column with the same or next greater length than the Final Main Run. This column will be used throughout the final gas sizing step for all the pipe sections.

11.3 Working example

The working example given below is to help understand the pipe sizing method further.

Step 1: Basic information:

- Gas type: NG
- Allowable pressure drop: 0.75 kPa
- Proposed layout of the consumer piping system, pipe section lengths, required fitting types, and appliance loads are show in the illustration below

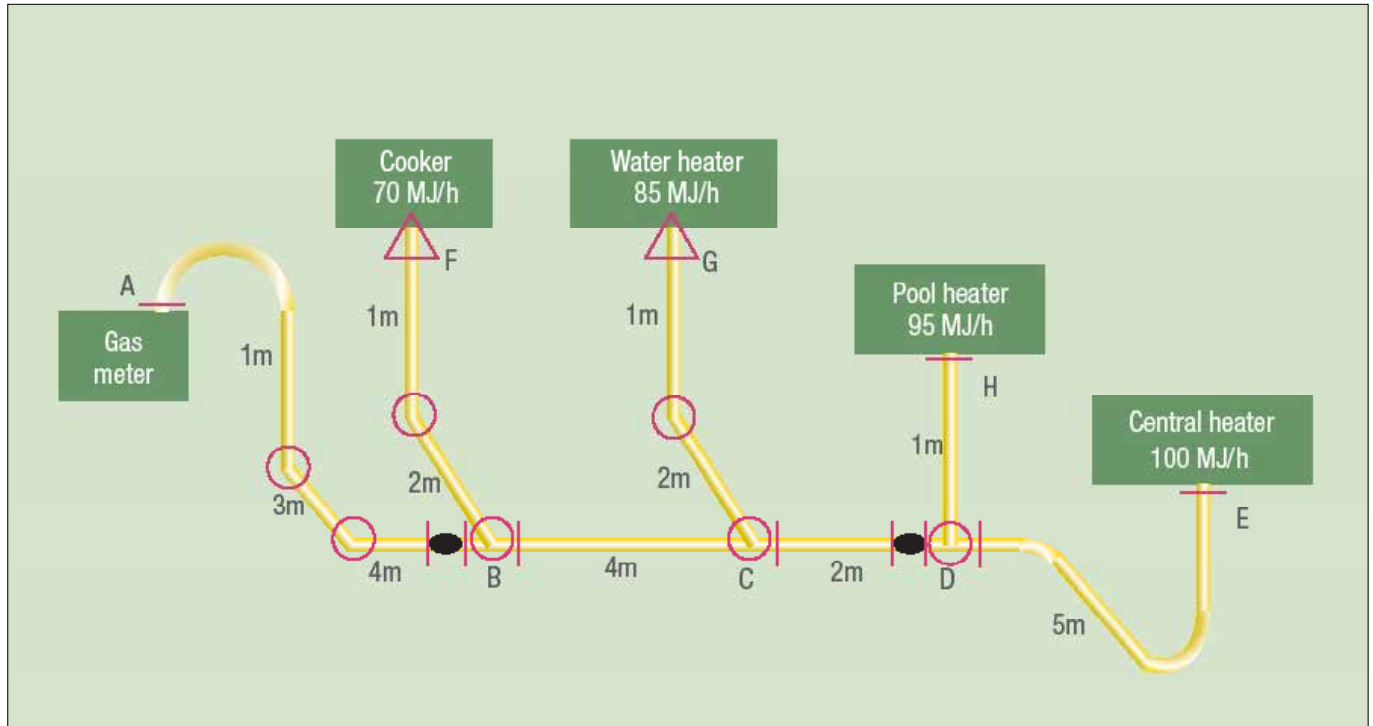

Fig. 12-1 Proposed layout of gas piping system

Symbol	Fittings included
	Coupler, T-straight, Male/Female straight adaptors, Connecting barb
○	Elbow, Elbow adaptor, T-branch
△	Wall-mounted elbows
●	Reversion fitting as per AS/NZS 5601.1 clause 5.2.13

Tab. 12-1 Fitting symbol used in working example

Step 2: Preliminary pipe sizing

- Based on the known basic information, we should use gas table for NG with allowable pressure drop of 0.75 kPa.
- Calculate the Preliminary Main Run, which is the longest pipe run from the gas meter (in this case from gas meter to central heater), is $8 (A-B) + 4 (B-C) + 2 (C-D) + 5 (D-E) = 19$ meters.

- Use the relevant gas table and identify the column to be used. Since there is no column with Main Run value of 19 meters, use the next higher value, which is 20 meters.
- Calculate the load of each pipe section (see Table 11-2 for load calculation for each pipe section).
- Select the correct pipe size that can carry the same or higher load rating for each pipe section.

**Pressure drop of 0.75 kPa
(Supply pressure of around 2.0 - 2.5 kPa)**

Pipes size	Pipe length in meters													
	2	4	6	8	10	12	14	16	18	20	25	30	35	
D-E B-F C-G D-H	16.2 x 2.6	238	164	131	112	100	90	83	77	72	68	61	55	51
← 20 x 2.9	465	320	257	220	195	176	162	151	142	134	119	107	99	
← 25 x 3.7	816	561	451	386	342	310	285	265	249	235	208	189	174	
← 32 x 4.7	1573	1081	868	743	659	597	549	511	479	453	401	363	334	
A-B B-C	40 x 6.0	2759	1896	1523	1303	1155	1047	963	896	841	794	704	638	587

Tab. 12-2 Selecting the correct preliminary pipe size for each pipe section

Section	Capacity	Pipe length	Preliminary pipe sizing				Final pipe sizing				
			Fitting group			Preliminary pipe OD	Fitting group EPL*			Total pipe section length	Final pipe OD
			I	II	III		I	II	III		
A-B	70+85+95+100=350	8				32					
B-C	85+95+100=280	4				32					
C-D	95+100=195	2				25					
D-E	100	5				20					
B-F	70	3				20					
C-G	85	3				20					
D-H	95	1				20					

Tab. 12-3 Preliminary gas pipe sizing

Step 3: Adding fittings to be installed in the system

- Determine the fittings to be installed in all pipe sections.

Section	Capacity	Pipe length	Preliminary pipe sizing				Final pipe sizing				
			Fitting group			Preliminary pipe OD	Fitting group EPL*			Total pipe section length	Final pipe OD
			I	II	III		I	II	III		
A-B	70+85+95+100=350	8	3	2	-	32					
B-C	85+95+100=280	4	1	-	-	32					
C-D	95+100=195	2	3	-	-	25					
D-E	100	5	2	-	-	20					
B-F	70	3	-	2	1	20					
C-G	85	3	-	2	1	20					
D-H	95	1	1	1	-	20					

Tab. 12-4 Adding fittings into the calculation

*EPL = Equivalent pipe length, refer to Appendix A5

- Add the fittings' Equivalent Pipe Lengths into each pipe section (refer to Appendix A5) based on the preliminary pipe sizing. Please note that T-pieces at point B, C and D have to

be considered twice. Those T-pieces are considered as T-flow for pipe sections B-C, C-D and D-E, and considered as T-branch for pipe sections B-F, C-G and D-H.

Section	Capacity	Pipe length	Preliminary pipe sizing				Final pipe sizing				
			Fitting group			Preliminary pipe OD	Fitting group EPL*			Total pipe section length	Final pipe OD
			I	II	III		I	II	III		
A-B	70+85+95+100=350	8	3	2	-	32	1.5	5.0	-	14.5	
B-C	85+95+100=280	4	1	-	-	32	0.5	-	-	4.5	
C-D	95+100=195	2	3	-	-	25	1.5	-	-	3.5	
D-E	100	5	2	-	-	20	1.0	-	-	6.0	
B-F	70	3	-	2	1	20	-	3.0	2.0	8.0	
C-G	85	3	-	2	1	20	-	3.0	2.0	8.0	
D-H	95	1	1	1	-	20	0.5	1.5	-	3.0	

Tab. 12-5 Adding fittings' equivalent pipe length into the calculation

Step 4: Confirming the preliminary pipe sizing

- Establish the Final Main Run using the new pipe section lengths. In this case the Final Main Run is 12 (A-B) + 4.5 (B-C) + 3.5 (C-D) + 6 (D-E) = 28.5 meters.
- Using the same gas table as in the preliminary pipe sizing step.

- Use the same load of each pipe section as in step 3.
- Identify the column to be used, as there is no column with Main Run value of 28.5 meters, look for column with value of 30 meters.
- Select the correct pipe size that can carry the same or higher load rating for each pipe section.

**Pressure drop of 0.75 kPa
(Supply pressure of around 2.0 - 2.5 kPa)**

Pipes size	Pipe length in meters													
	2	4	6	8	10	12	14	16	18	20	25	30	35	
D-E														
B-F	16.2 x 2.6	238	164	131	112	100	90	83	77	72	68	61	55	51
C-G														
D-H	20 x 2.9	465	320	257	220	195	176	162	151	142	134	119	107	99
	25 x 3.7	816	561	451	386	342	310	285	265	249	235	208	189	174
A-B														
B-C	32 x 4.7	1573	1081	868	743	659	597	549	511	479	453	401	363	334
C-D														
	40 x 6.0	2759	1896	1523	1303	1155	1047	963	896	841	794	704	638	587

Tab. 12-6 Selecting the correct final pipe size for each pipe section

Section	Capacity	Pipe length	Preliminary pipe sizing				Final pipe sizing				
			Fitting group			Preliminary pipe OD	Total fitting group EPL			Total pipe section length	Final pipe OD
			I	II	III		I	II	III		
A-B	70+85+95+100=350	8	3	2		32	1.5	5.0	-	14.5	32
B-C	85+95+100=280	4	1	-	-	32	0.5	-	-	4.5	32
C-D	95+100=195	2	3	-	-	25	1.5	-	-	3.5	32
D-E	100	5	2	-	-	20	1.0	-	-	6.0	20
B-F	70	3	-	2	1	20	-	3.0	2.0	8.0	20
C-G	85	3	-	2	1	20	-	3.0	2.0	8.0	20
D-H	95	1	1	1	-	20	0.5	1.5	-	3.0	20

Tab. 12-7 Confirmed gas pipe size selection

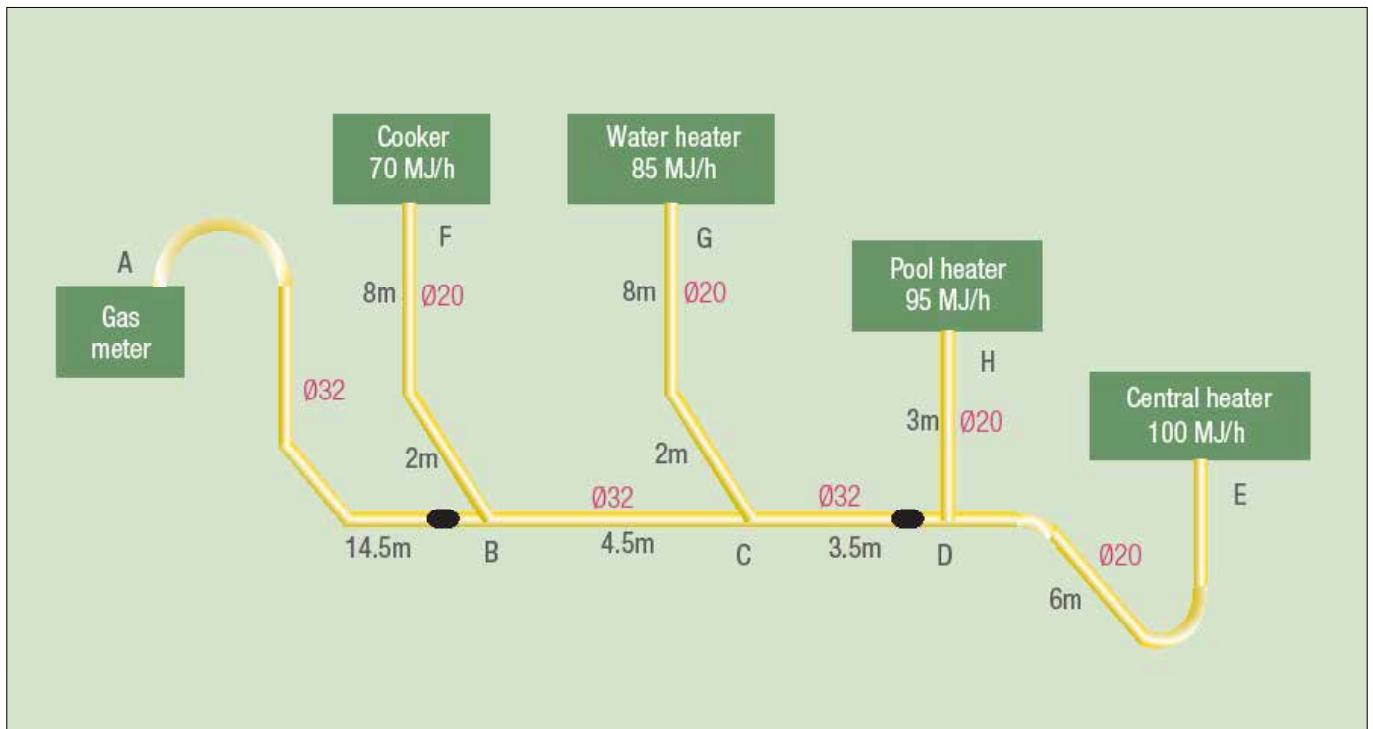

Fig. 12-8 Final gas pipe sketch with pipe sizes



There is a change of pipe size for pipe section C-D, from 25 mm to 32 mm, due to addition of fittings' Equivalent Pipe Lengths.

13.2 Standards, Regulations and Guidelines



Observe the applicable national and international laying, installation, accident prevention and safety regulations when installing piping systems, as well as the instructions in this Technical Information.

Also observe the applicable laws, standards, guidelines and regulations (e.g. DIN, EN, ISO, DVGW, TRGI, VDE and VDI) as well as regulations on environmental protection, provisions of professional associations and regulations of the local public utility companies.

Areas of application not contained in this Technical Information (special applications) require consultation with our Applications Department. For extensive advice, consult your REHAU sales office.

The planning and installation instructions are directly connected with the respective REHAU product. References are made to excerpts from generally applicable standards and regulations.

Observe the respectively valid issues of the guidelines, standards and regulations. Further standards, regulations and guidelines with regard to the planning, installation and operation of drinking water, heating and building technology systems must also be taken into account but are not a part of this Technical Information.

The following standards, regulations and guidelines are referred to in the Technical Information (the current version is always valid):

AS 1530.4

Methods for fire tests on building materials, components and structures - Fire-resistance test of elements of construction

AS 1722.1

Pipe threads of Whitworth form - Sealing pipe threads

AS 1722.2

Pipe threads of Whitworth form - Fastening pipe threads

AS 2345

Dezincification resistance of copper alloys

AS/NZS 2537

Mechanical jointing fittings for use with cross-linked polyethylene (PE-X) pipe for hot and cold water applications

AS 3688

Water supply - Metallic fittings and end connectors

AS/NZS 2492

Cross-linked polyethylene (PE-X) pipes for pressure applications

AS 4176

Multilayer pipes for pressure applications

AS/NZS 3718

Water supply - Tape ware

AS/NZS 4020

Testing of products for use in contact with drinking water

AS/NZS 3500

Plumbing and drainage set

AS/NZS 5601.1

Gas installation

Australian Drinking Water Guidelines

BCA/NCC

Building code of Australia/National Construction Code

PCA/NCC

Plumbing Code of Australia/National Construction Code

NZBC

New Zealand Building Code

DIN 16892

Crosslinked polyethylene (PE-X) pipes - General requirements, testing

DIN 16893

Crosslinked polyethylene (PE-X) pipes - Dimensions

DIN 1988

Codes of practice for drinking water installations (TRWI)

DIN 2000

Central drinking water supply - Guidelines regarding requirements for drinking water, planning, construction, operation and maintenance of plants

DIN 4102

Fire behaviour of building materials and components

DIN 4108

Thermal insulation in buildings

DIN 4109

Sound insulation in buildings

DIN 4725

Warm water surface heating systems - Systems and components

DIN 4726

Warm water surface heating systems and radiator connecting systems - Plastic piping systems

DIN 50916-2

Testing of copper alloys; stress corrosion and cracking test using ammonia; testing of components

DIN 50930-6

Corrosion of metals – Corrosion of metallic under corrosion load by water inside of tubes, tanks and apparatus - Part 6: Influence of the composition of drinking water.

DIN EN 10088 Stainless steels	DIN EN ISO 6509 Corrosion of metals and alloys – Determination of dezincification resistance of brass
DIN EN 10226 Pipe threads where pressure-tight joints are made on the threads	DIN V 4108-6 Thermal protection and energy-economy in buildings
DIN EN 12165 Copper and copper alloys – Wrought and unwrought forging stock	DVGW W 291 Cleaning and disinfection of water distribution systems
DIN EN 12168 Copper and copper alloys - Hollow rod for free machining purposes	DVGW W 534 Pipe connectors and connections in the drinking water installation
DIN EN 12502-1 Protection of metallic materials against corrosion – Guidance on the assessment of corrosion likelihood in water distribution and storage systems	DVGW W 551 Drinking water heating and drinking water pipe systems
DIN EN 12828 Heating systems in buildings – Design of water-based heating systems	ISO 228 Pipe threads where pressure-tight joints are not made on the threads
DIN EN 12831 Heating systems in buildings	ISO 7 Pipe threads where pressure-tight joints are not made on the threads
DIN EN 12831 Supplementary sheet 1 Heating systems in buildings – Method for calculation of the design heat load	VDI 6023 Hygiene for drinking water supply systems
DIN EN 13163 Thermal insulation products for buildings	
DIN EN 13163 to DIN EN 13171 Thermal insulation products for buildings	
DIN EN 13501 Fire classification of construction products and building elements	
DIN EN 14291 Foam producing solutions for leak detection on gas installations	
DIN EN 14336 Heating systems in buildings	
DIN EN 15377 Heating systems in buildings	
DIN EN 1717 Protection against pollution of potable water installations and general requirements of devices to prevent pollution by backflow	
DIN EN 442 Radiators and convectors	
DIN EN 806 Codes of practice for drinking water installations	
DIN EN ISO 15875 Plastic piping systems for hot and cold water installations - Crosslinked polyethylene (PE-X)	

Appendix

- A1 Application of corrosion protection system for fittings installed below ground
- A2 RAUGUARD protective conduit installation
- A3 Pressure drop table RAUTITAN gas stabil (Natural gas)
- A4 Pressure drop tables RAUTITAN gas stabil (LPG)
- A5 RAUTITAN Gas fittings - Equivalent pipe lengths
- A6 Form: Pressure test for gas application
- A7 Form: Pressure test for water application
(Test medium: water)
- A8 Form: Pressure test for water application
(Test medium: air)

***Note:**

Pressure loss tables for RAUTITAN PE-Xa pipes (cold and hot water) and RAUTITAN stabil pipes (cold and hot water) can be found on www.rehau.com.au/RAUTITAN or www.rehau.co.nz/RAUTITAN

Appendix A1

Application of corrosion protection system for fittings in installed below ground

Incorrect application of the system components can compromise its performance and result in gas fitting corrosion. Corroded components can cause joint failure and lead to leakage.

- For more detailed information on correct handling and application, carefully read the individual instruction leaflets supplied with each component of the Corrosion Protection System prior to use.
- REHAU requires a minimum protection extension of 150 mm to each side of the joint. This minimum requirement overrules some of the manufacturers' instruction.



The procedure of corrosion protection system given below is only an example specific to DEKOTEC N15/PE5 system. Other equivalent corrosion protection systems may have different procedure and tape colours. Please follow the procedures given by corrosion protection systems' manufacturers.

STEP 1: Surface preparation of protection area

- Clean the protection area, ensure that it is dry and free from grease and dust.

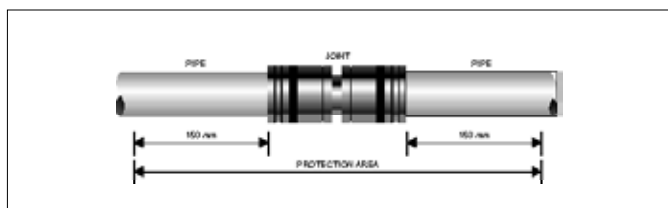

Fig. A1-1 Protection area for corrosion protection system

- Completely remove any contamination which might act as a release agent (e.g. grease, oil, coupling agents, paint, cement, varnish, etc.) prior to tape application.
- Roughen the cleaned pipe surface 150 mm on each side of the joint using coarse emery cloth. Remove any grinding dust afterwards.

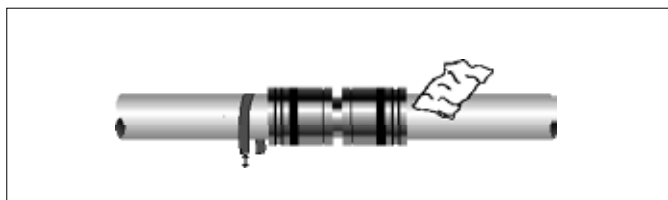

Fig. A1-2 Roughen the pipe surface and clean the grinding dust after the roughening process

- Thoroughly stir the corrosion protection primer in original container to ensure uniformity prior to application.
- Using a brush or roller apply an even coating of primer to the cleaned and dried surface over the entire protection area. Surfaces have to be uniformly coated and cover must extend for a minimum of 150 mm on each side of the fitting (complete protection area).
- After use immediately seal the primer container.
- Clean the brush or roller with suitable solvent (e.g. white spirit).

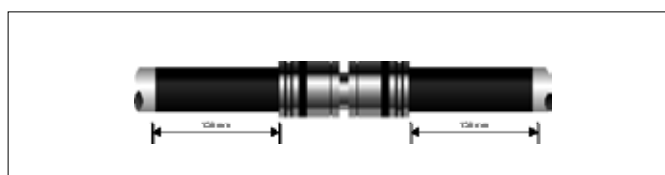

Fig. A1-3 Primed protection area surface

- Let primer coating dry until it is tack free and all solvents have evaporated.
- The drying time depends on ambient temperature and air movement.
- The primed surface should be wrapped within 8 hours. Otherwise or in case of contamination (e.g. dust) the primer coating has to be renewed.

STEP 2: Profiling the protection area

- Gaps and voids between pipe/fitting and the corrosion protection tape must be avoided to ensure proper protection.
- The fitting has to be contoured to ensure full contact between the corrosion protection tape and the substrate being protected. Corrosion protection mastic is to be used for profiling as part of the corrosion protection system.

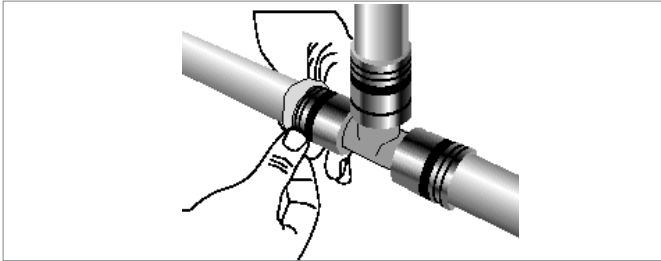

Fig. A1-4 Filling the gaps between fitting and pipe with mastic

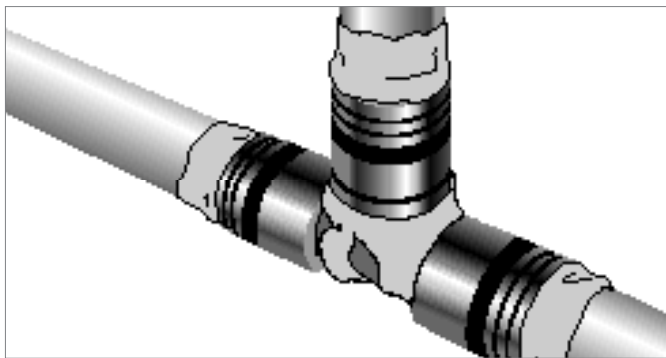

Fig. A1-5 Profiled protection area

STEP 3: First wrap of the protection area

- Starting at one end of the protection area (minimum 150 mm from compression sleeve) apply the inner tape (grey colour) with one circumferential wrap and continue wrapping it spirally with minimum 50% overlap across the complete protection area.

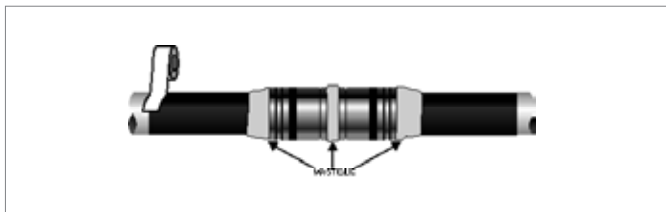

Fig. A1-6 Wrapping the protection area with the first tape (grey colour)

- Apply slight pressure while wrapping to ensure good bonding to the substrate.
- Keep the tape under tension to avoid any kinks and creases. A good indicator for sufficient tension is if the tape's width is narrowed by approximately 1% during application. Remove the separating foil.

- The tape wrapping shall cover the complete jointing and extend by at least 150 mm beyond the protected joint onto the pipe (protection area).

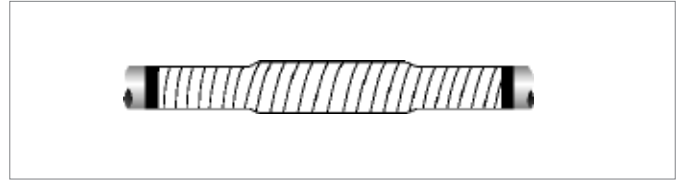

Fig. A1-7 First tape wrapping of complete protection area

STEP 4: Final wrap of protection area

- The outer wrap (black/grey tape) must at least fully cover the first wrap. Position the black/grey tape at one end of the protection area with half of it covering the inner wrap and the grey surface facing the inner wrap, the black side facing outward.



Fig. A1-8 Wrapping the protection area with black/grey tape

- Apply one circumferential wrap and continue wrapping it spirally with minimum 50% overlap across the complete protection area.
- Keep the tape under tension to avoid any kinks and creases. A good indicator for sufficient tension is if the tape's width is narrowed by approximately 1% during application.
- The tape wrapping should cover the complete pipe and extend by at least 150 mm beyond the protected joint (protection area).

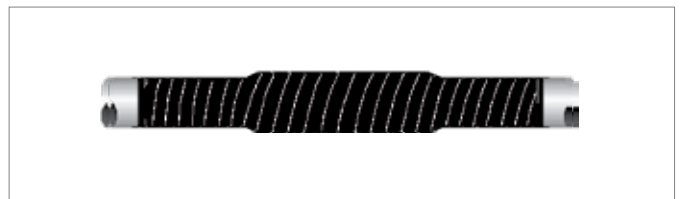

Fig. A1-9 Fully protected joint with corrosion protection system

No wrinkles, creases or kinks are allowed in the finished wrapping on visual testing.

Appendix A2

RAUGUARD protective conduit installation

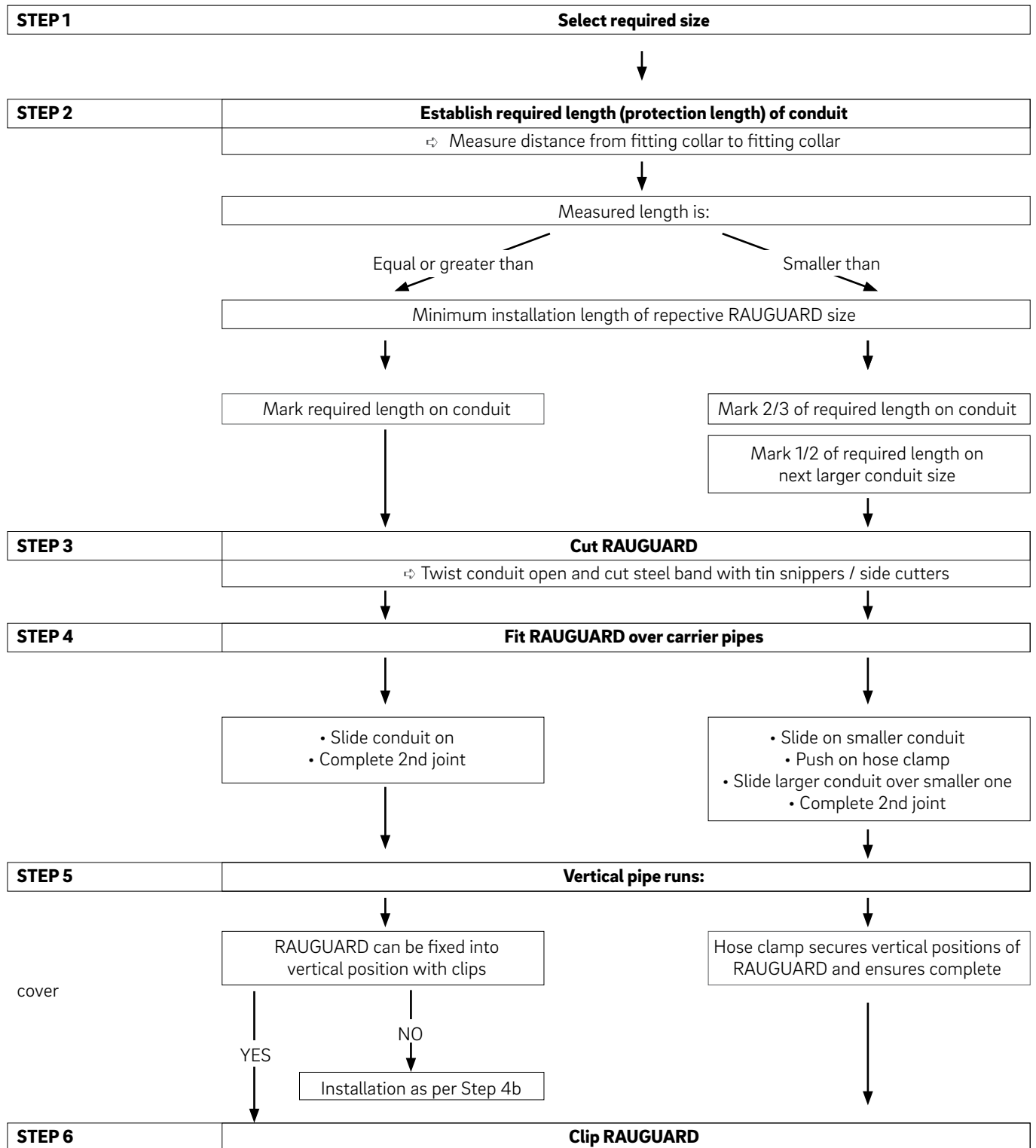

Fig. A2-1 RAUGUARD installation sequence

STEP 1: Select required size

RAUGUARD sizes are matched to the respective RAUTITAN gas stabil pipes to ensure the carrier pipes can be completely protected from one fitting to the next. Use Table A2-1 for selecting the correct RAUGUARD size.

To protect very short sections of RAUTITAN gas stabil 40 x 6.0, a combination of RAUGUARD 40 and 40+ is required. Please refer to next section for details.

RAUTITAN gas stabil OD x wall thickness	RAUGUARD
16.2 x 2.6	RAUGUARD 16/20
20 x 2.9	RAUGUARD 16/20
25 x 3.7	RAUGUARD 25
32 x 4.7	RAUGUARD 32
40 x 6.0	RAUGUARD 40
40 x 6.0	RAUGUARD 40+

Tab. A2-1 Available RAUGUARD sizes

STEP 2: Establish required length

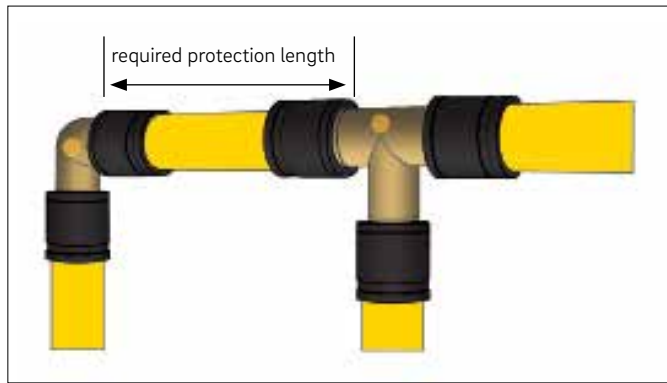

Fig. A2-2 Required protection length to be covered by RAUGUARD



For full protection against vermin, RAUGUARD must cover the RAUTITAN gas stabil pipes completely from fitting collar to fitting collar. If this is not the case, rodent can damage the pipe resulting in a gas leak.

To achieve a complete cover of the pipes, the following must be observed:

- An accurate measurement of the required protection length.
- Before marking the cut length of the RAUGUARD, it must be in a relaxed condition.

The required protection length is the distance from fitting collar to fitting collar, i.e. RAUGUARD must not cover only the pipe itself but also the compression sleeves on each fitting as shown in Figure A2-2.

To determine the required cut length of RAUGUARD, the following needs to be considered:

- Three conditions are possible for RAUGUARD:
 - Relaxed - natural position, the conduit is not under any external forces.
 - Extended - conduit is stretched.
 - Contracted - conduit is compressed.
- The length of RAUGUARD in each of the three conditions differs with its size.
- To complete a REHAU compression sleeve joint, RAUGUARD must be pushed away from the cut pipe end by a minimum of three times the length of the compression sleeve. This will allow an unrestricted expansion process of the pipe. (see Figure A2-3).

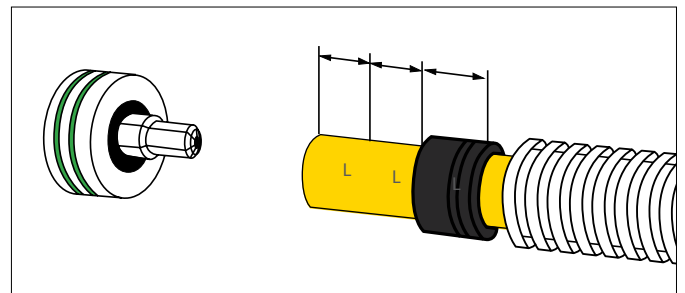

Fig. A2-3 Minimum of free pipe length to complete expansion process

RAUGUARD has to be installed in its natural condition, without any external forces applied to it. Each RAUGUARD size can be compressed to a minimum length which varies with its diameter. The minimum installation length of each RAUGUARD size, as listed in Table A2-2, is derived from the fully contracted RAUGUARD together with the three times the length of the respective compression sleeve size.

RAUGUARD	RAUTITAN gas stabil size	Minimum installation length in meters [m]
RAUGUARD 16/20	16.2 x 2.6	1.5
RAUGUARD 16/20	20 x 2.9	1.5
RAUGUARD 25	25 x 3.7	1.0
RAUGUARD 32	32 x 4.7	0.75
RAUGUARD 40	40 x 6.0	0.6
RAUGUARD 40+	40 x 6.0	0.6

Tab. A2-2 Minimum installation lengths based on RAUGUARD and carrier pipe size

As a result of the considerations listed above, there are two possibilities:

- The required protection length is **greater** than the minimum installation length. In this case, ensure RAUGUARD is in its relaxed condition / natural length and mark the required protection length on the conduit before cutting it.

OR

- The required protection length is **shorter** than the minimum installation length. This means two different RAUGUARD sizes have to be used. Ensure the respective RAUGUARD is in its relaxed condition and mark two-third of the required protection length and cut it. Select the next larger RAUGUARD size and mark half of the protection length; again, ensure the conduit is in its relaxed condition before cutting the conduit. The larger RAUGUARD slides easily over the smaller making it possible to push it back far enough to complete the REHAU compression sleeve joint.

When marking the cut length on conduit always ensure RAUGUARD is in its natural length.

step 3: Cut RAUGUARD



Danger of cutting injuries!

Inappropriate handling of RAUGUARD and cutting tools can result in severe cutting injuries or severed limbs.

- Maintain safe distance between cutting tool and your hand holding the conduit.
- Check for sharp edges and corners when handling RAUGUARD.

RAUGUARD can be separated by gripping it with both hands placed closely together and twisting both hands against each other in the direction indicated in Figure A2-4.

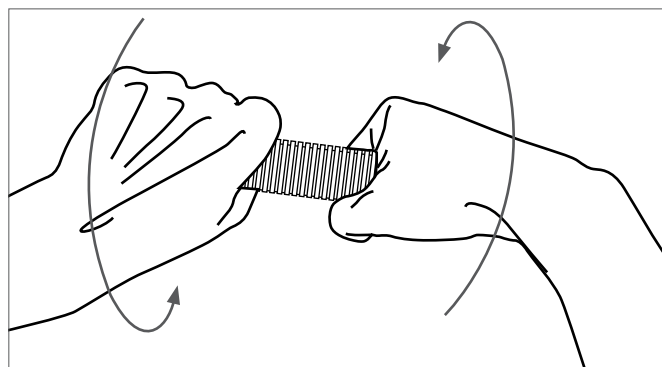

Fig. A2-4 Separating RAUGUARD

The now exposed single steel band can be easily cut with any commonly available tin snippers or side cutters as shown in Figure A2-5.



Fig. A2-5 Cutting of RAUGUARD

STEP 4: Fit RAUGUARD over carrier pipes



Never install RAUGUARD with the cut edges facing towards the carrier pipe, as this can damage the pipe resulting in a gas leak. Check RAUGUARD for sharp edges, and if present, remove them before fitting conduit onto pipes.

The installation procedures of the two possible conditions for RAUGUARD during installation, as mentioned in Step 2, are now explained in greater detail.

STEP 4a: Required protection length is longer than minimum installation length

- Feed RAUGUARD completely onto the carrier pipe making sure the far end fully covers the compression sleeve as shown in Figure A2-6.

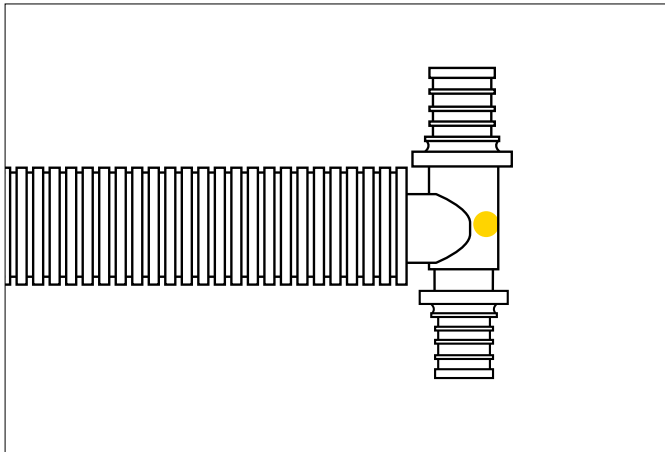

Fig. A2-6 Push RAUGUARD all the way against the fitting

- Compress conduit by at least three times the compression sleeve length to expose sufficient carrier pipe for correct expansion.

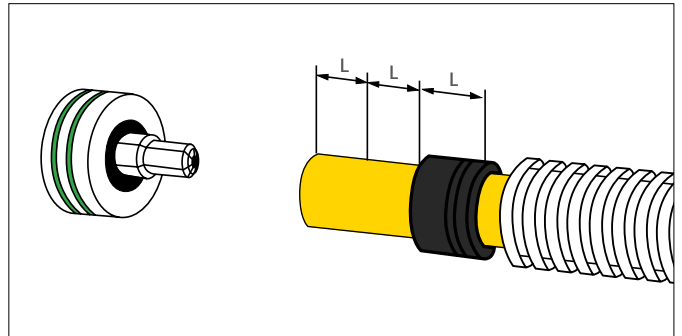

Fig. A2-7 Minimum of free pipe length to complete expansion process

- Complete the REHAU compression sleeve joint in a normal fashion.

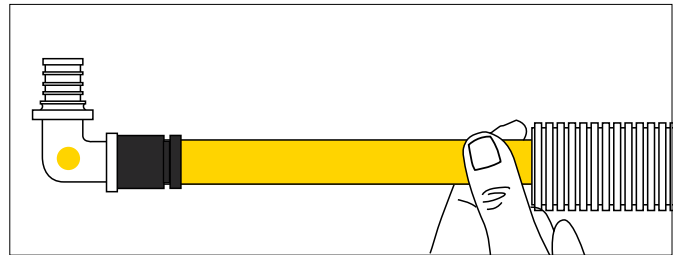

Fig. A2-8 Second joint completed - RAUGUARD is still pushed back

- Pull back RAUGUARD all the way to the fitting, making sure it covers both compression sleeves fully.

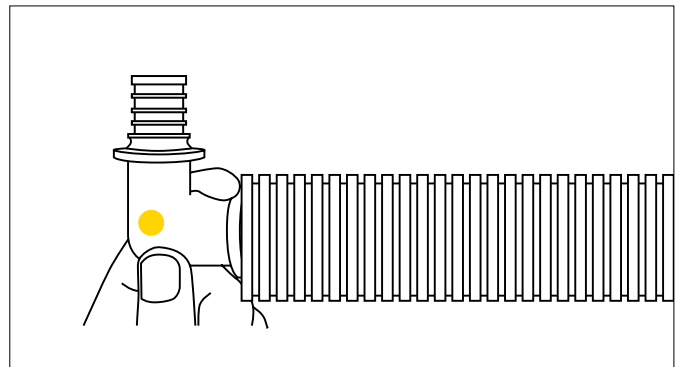

Fig. A2-9 RAUGUARD pulled back over the second joint, covering compression sleeve

STEP 4b: Required protection length is shorter than minimum installation length

- Feed the smaller RAUGUARD completely onto the carrier pipe; make sure the far end fully covers the compression sleeve as shown in Figure A2-10.

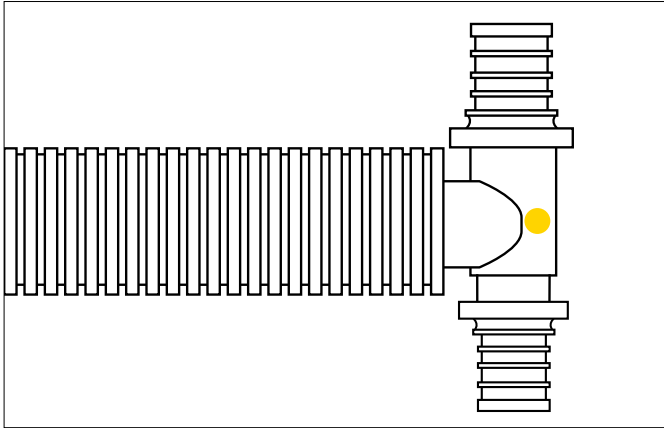

Fig. A2-10 Pushing RAUGUARD all the way against the fitting

- Slip a suitable hose clamp (see Figures A2-11 and A2-12) onto the RAUGUARD.

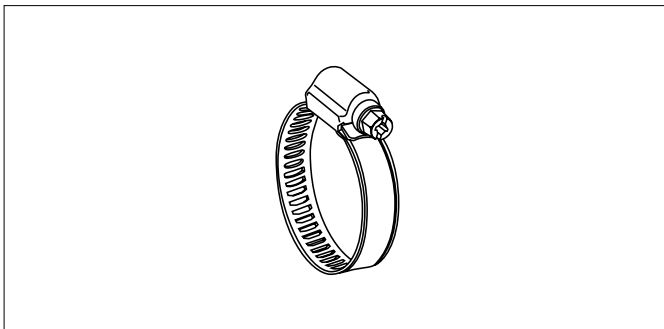

Fig. A2-11 Common hose clamps with worm drive

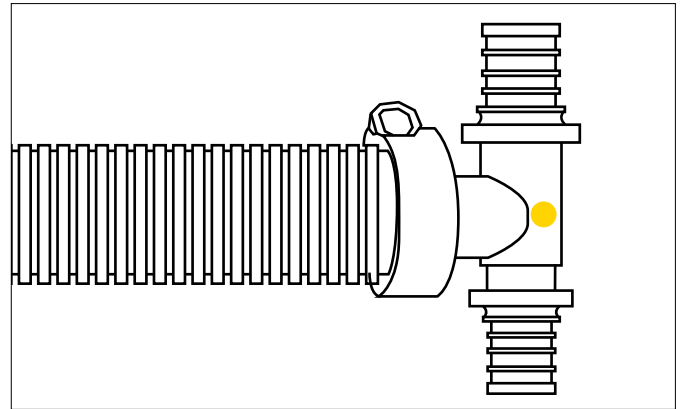

Fig. A2-12 Hose clamp over RAUGUARD

- Feed the larger RAUGUARD onto the carrier pipe and over the smaller RAUGUARD until sufficient carrier pipe length is exposed (at least three times the compression sleeve length) to ensure a safe pipe expansion (see Figure A2-13).
- Complete the REHAU compression sleeve joint in a normal fashion.

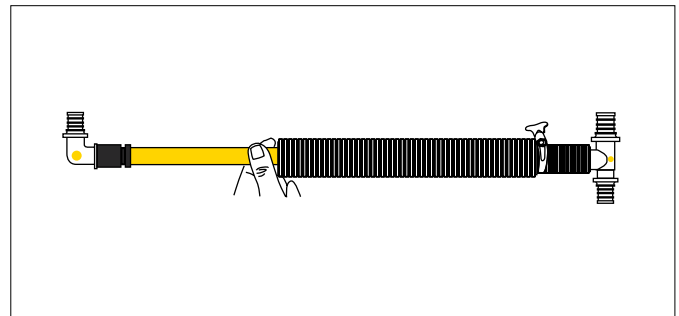

Fig. A2-13 Second joint completed - Larger RAUGUARD pushed back over smaller RAUGUARD

- Push both conduits against the fittings and lock into place with the hose clamping, making sure both conduits fully cover the compression sleeves at each end.

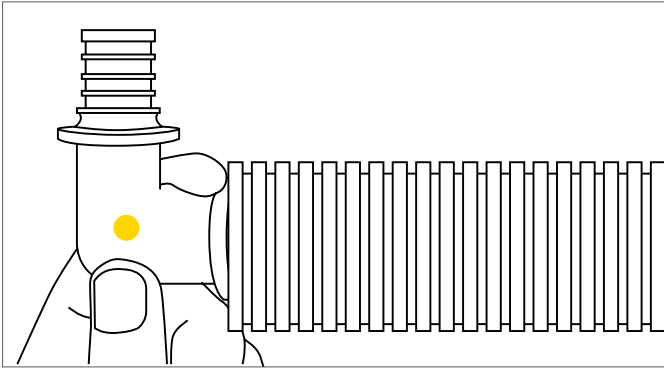

Fig. A2-14 RAUGUARD pulled back over the second joint, covering compression sleeve

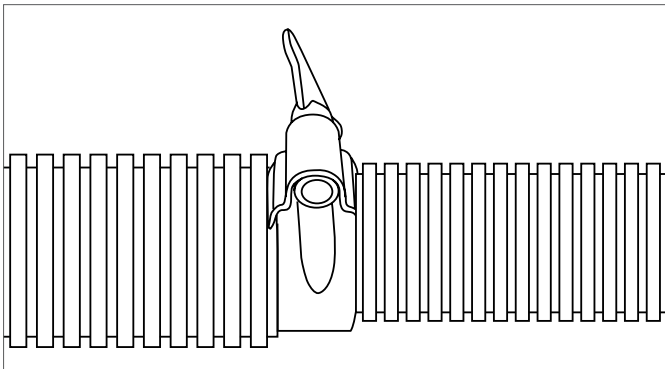

Fig. A2-15 RAUGUARD fixed with hose clamp

- ✓ For horizontal runs, RAUGUARD does not have to be fitted in one continuous length cut offs from previous sections can be used and simply be taped together where both ends meet

step 5: Protect vertical pipe runs with RAUGUARD

When installed vertically, due to gravity, an unrestrained RAUGUARD will always sit in its compressed position. In such cases, RAUGUARD has to be clipped in place to ensure it also covers the upper pipe end and the fitting.

RAUGUARD 16/20 can also be secured against slipping down with REHAU pipe bend brackets size 32, if the pipe-run continues horizontally from the top as depicted in Figure A2-16.

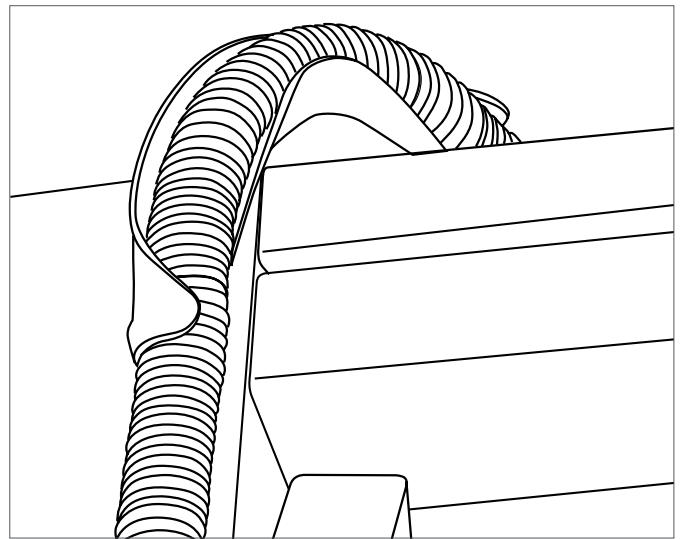

Fig. A2-16 Fixing vertical RAUGUARD 16/20 into place with bend bracket

If it is not possible to fix RAUGUARD into position, the application of RAUGUARD follows the procedure given in the previous chapter for protecting pipe runs shorter than the minimum installation length of RAUGUARD.

The hose clamp locks both conduits into position making it possible to fully protect the fitting at the top and the upper part of the pipe as shown in Figure A2-17.

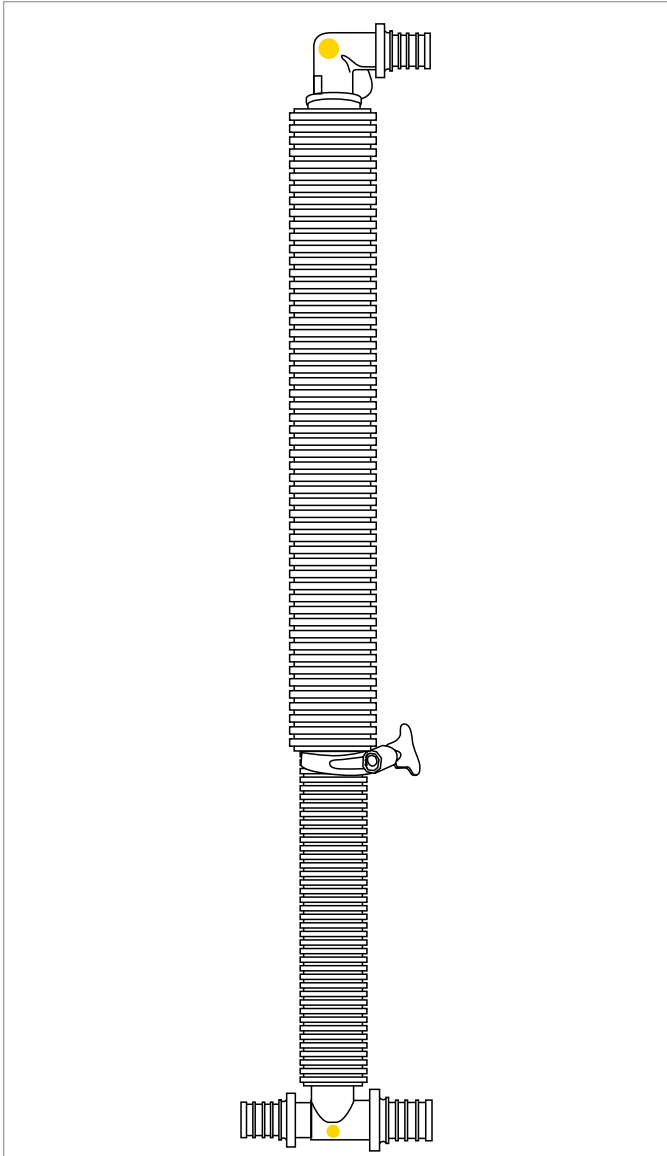

Fig. A2-17 Vertical RAUGUARD installation lock into position with hose clamp

STEP 6: Clip RAUGUARD

Common electrical conduit brackets can be used to clip RAUGUARD as shown in Figure A2-18. The spacing of clips is according to the guidelines in Section: Pipe support and fixing.

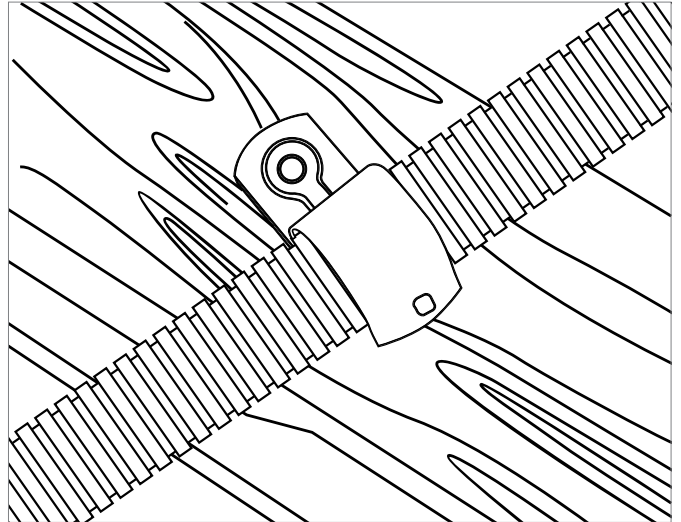

Fig. A2-18 RAUGUARD with common electrical clip

Appendix A3

Pressure drop tables RAUTITAN gas stabil (natural gas)

Natural Gas (NG)

Flow rates based on:

- Pressure: 1023.15 mbar
- Gas temperature: 15°C
- Heating value (gross): 38.7 MJ/m³

Pressure drop of 0.075 kPa

(Supply pressure of around 1.1 kPa)

Pipe size	Pipe length in meters												
	2	4	6	8	10	12	14	16	18	20	25	30	35
16.2 x 2.6	68	47	38	32	29	26	22	19	17	15	12	10	9
20 x 2.9	134	92	74	63	56	51	47	43	41	38	34	28	24
25 x 3.7	235	161	130	111	98	89	82	76	72	68	60	54	50
32 x 4.7	453	311	250	214	189	172	158	147	138	130	115	105	96
40 x 6.0	794	546	438	375	332	301	277	258	242	228	202	183	169

Pipe size	Pipe length in meters												
	40	45	50	55	60	65	70	75	80	85	90	95	100
16.2 x 2.6	8	7	6	6	5	5	4	4	4	4	3	3	3
20 x 2.9	21	19	17	16	14	13	12	11	11	10	9	9	9
25 x 3.7	46	44	40	37	34	31	29	27	25	24	22	21	20
32 x 4.7	90	84	79	75	72	69	66	64	62	60	58	56	55
40 x 6.0	157	147	139	132	126	121	116	112	108	104	101	98	96

**Pressure drop of 0.12 kPa
(Supply pressure of around 1.25 kPa)**

Pipe size	Pipe length in meters												
	2	4	6	8	10	12	14	16	18	20	25	30	35
16.2 x 2.6	88	61	49	42	37	33	31	29	27	25	20	16	14
20 x 2.9	172	119	95	81	72	65	60	56	53	50	44	40	37
25 x 3.7	303	208	167	143	127	115	106	98	92	87	77	70	64
32 x 4.7	584	401	322	276	244	221	204	189	178	168	149	135	124
40 x 6.0	1024	704	565	484	429	388	357	332	312	295	261	237	218

Pipe size	Pipe length in meters												
	40	45	50	55	60	65	70	75	80	85	90	95	100
16.2 x 2.6	12	11	10	9	8	8	7	7	6	6	5	5	5
20 x 2.9	34	30	27	25	23	21	20	18	17	16	15	14	14
25 x 3.7	60	56	53	50	48	46	44	43	40	38	36	34	32
32 x 4.7	115	108	102	97	93	89	85	82	79	77	74	72	70
40 x 6.0	202	190	179	170	163	156	150	144	139	135	131	127	123

**Pressure drop of 0.25 kPa
(Supply pressure of around 1.5 - 2.0 kPa)**

Pipe size	Pipe length in meters												
	2	4	6	8	10	12	14	16	18	20	25	30	35
16.2 x 2.6	131	90	72	62	55	50	46	43	40	38	33	30	28
20 x 2.9	257	176	142	121	107	97	90	83	78	74	65	59	55
25 x 3.7	451	310	249	213	189	171	157	146	137	130	115	104	96
32 x 4.7	868	597	479	410	363	329	303	282	264	250	221	201	185
40 x 6.0	1523	1047	841	719	638	578	531	494	464	438	388	352	324

Pipe size	Pipe length in meters												
	40	45	50	55	60	65	70	75	80	85	90	95	100
16.2 x 2.6	26	23	20	19	17	16	15	14	13	12	11	11	10
20 x 2.9	51	48	45	43	41	39	37	36	35	33	32	30	28
25 x 3.7	89	84	79	75	72	69	66	63	61	59	57	56	54
32 x 4.7	172	161	152	145	138	132	127	122	118	114	111	108	105
40 x 6.0	301	283	267	254	242	232	223	214	207	200	194	189	183

Pressure drop of 0.75 kPa
(Supply pressure of around 2.0 - 2.5 kPa)

Pipe size	Pipe length in meters												
	2	4	6	8	10	12	14	16	18	20	25	30	35
16.2 x 2.6	238	164	131	112	100	90	83	77	72	68	61	55	51
20 x 2.9	465	320	257	220	195	176	162	151	142	134	119	107	99
25 x 3.7	816	561	451	386	342	310	285	265	249	235	208	189	174
32 x 4.7	1573	1081	868	743	659	597	549	511	479	453	401	363	334
40 x 6.0	2759	1896	1523	1303	1155	1047	963	896	841	794	704	638	587

Pipe size	Pipe length in meters												
	40	45	50	55	60	65	70	75	80	85	90	95	100
16.2 x 2.6	47	44	42	40	38	36	35	33	32	31	30	29	29
20 x 2.9	92	86	81	77	74	71	68	65	63	61	59	58	56
25 x 3.7	161	151	143	136	130	124	119	115	111	107	104	101	98
32 x 4.7	311	292	276	262	250	239	230	221	214	207	201	195	189
40 x 6.0	546	512	484	459	438	420	403	388	375	363	352	342	332

Pressure drop of 1.5 kPa
(Supply pressure of around 2.75 - 5.0 kPa)

Pipe size	Pipe length in meters												
	2	4	6	8	10	12	14	16	18	20	25	30	35
16.2 x 2.6	346	238	191	164	145	131	121	112	105	100	88	80	74
20 x 2.9	676	465	373	320	283	257	236	220	206	195	172	156	144
25 x 3.7	1188	816	656	561	497	451	415	386	362	342	303	274	252
32 x 4.7	2289	1573	1263	1081	958	868	799	743	697	659	584	529	487
40 x 6.0	4015	2759	2216	1896	1681	1523	1401	1303	1223	1155	1024	928	853

Pipe size	Pipe length in meters												
	40	45	50	55	60	65	70	75	80	85	90	95	100
16.2 x 2.6	68	64	61	58	55	53	51	49	47	46	44	43	42
20 x 2.9	134	126	119	113	107	103	99	95	92	89	86	84	81
25 x 3.7	235	220	208	198	189	181	174	167	161	156	151	147	143
32 x 4.7	453	425	401	381	363	348	334	322	311	301	292	283	276
40 x 6.0	794	745	704	668	638	611	587	565	546	528	512	497	484

Appendix A4

Pressure drop tables RAUTITAN gas stabil (LPG)

Liquefied Petroleum Gas (LPG)

Flow rates based on:

- Pressure: 1023.15 mbar
- Gas temperature: 15°C
- Heating value (gross): 95.4 MJ/m³

Pressure drop of 0.25 kPa (Supply pressure of around 3.0 kPa)

Pipe size	Pipe length in meters												
	2	4	6	8	10	12	14	16	18	20	25	30	35
16.2 x 2.6	225	155	124	106	94	85	79	73	69	65	57	52	48
20 x 2.9	440	303	243	208	184	167	154	143	134	127	112	102	94
25 x 3.7	773	531	427	365	324	293	270	251	236	222	197	179	164
32 x 4.7	1490	1024	822	704	624	565	520	484	454	429	380	344	317
40 x 6.0	2613	1796	1442	1234	1094	991	912	848	796	752	666	604	555

Pipe size	Pipe length in meters												
	40	45	50	55	60	65	70	75	80	85	90	95	100
16.2 x 2.6	45	42	39	38	36	34	33	32	31	30	29	28	27
20 x 2.9	87	82	77	73	70	67	64	62	60	58	56	55	53
25 x 3.7	153	143	136	129	123	118	113	109	105	102	99	96	93
32 x 4.7	295	276	261	248	237	227	218	210	202	196	190	184	179
40 x 6.0	517	485	458	435	415	397	382	368	355	344	333	324	315

Appendix A5

RAUTITAN gas fittings - equivalent pipe lengths

Equivalent pipe length for gas fittings.

Fitting Symbol	Included Fittings	Equivalent Pipe Length				
		16.2	20	25	32	40
	Coupler Reducing coupler Connecting barb					
	T-flow			0.5		
	Straight male adaptor Straight female adaptor					
○	Elbow Elbow adapter					
	T-branch	0.5	1.5	1.5	2.5	3.0
△	Female threaded wall-mounted elbow Male threaded wall-mounted elbow	0.5	2.0	3.0	3.0	-

Appendix A6

Form: Pressure test for gas application



1. Installation Data		
Building	Protocol N°	Location
Respective part of building (e.g. Apartment 1, etc.)	Area (e.g. basement, 1st floor, etc.)	
2. Pressure Test for installations up to 30 l volume in the pipework as per AS/NZS 5601.1		
	Testing without appliances connected	Testing with appliances connected
Day of test:		
Ambient temperature:	°C	°C
Test Pressure:	kPa	kPa
Requirement:	The higher of 7 kPa or 1.5 x operating pressure	Operating pressure (min. 2 kPa)
Temperature stabilization period:	min. (minimum 2 min.)	min. (minimum 2 min.)
Test duration	min.	min.
Requirement:	5 min.	5 min.
Pressure drop	kPa	kPa
Requirement:	0 kPa	0 kPa
Tester (Name)		
Signature:		
<p>The information and signature provided above are confirmation that the RAUTITAN gas system has been installed in accordance with the REHAU Technical Information, the applicable gas installation standards for this and that the installation is safe.</p>		
Location	Date	
REHAU Authorised Installer	Company stamp	

Approximate pipe length of RAUTITAN gas stabil holding a volume of 0.03 m ³ (=30 l)					
	16.2 x 2.6	20 x 2.9	25 x 3.7	32 x 4.7	40 x 6.0
Approx. length in metre:	316 m	190 m	123 m	75 m	48 m

Master copy, duplication permitted

Appendix A7

Form: Pressure test for water application
(Test medium: water)



Pressure test record: REHAU RAUTITAN system (drinking water installation)

1. Project

Project Name: _____
 Client: _____
 Address/House No.: _____
 Post Code/Town/City: _____

2. Pressure test

RAUTITAN stabil pipes	RAUTITAN PE-Xa pipes
ΔT _____ K ($\Delta T = T_{\text{ambient}} - T_{\text{water}}$)	Test pressure _____ bar (maximal operating pressure 10 bar x 1.1 = 11 bar)
Test pressure _____ bar (maximal operating pressure 10 bar x 1.1 = 11 bar)	Waiting time _____ min (min. waiting time 30 minutes)
Adaption time _____ min 10 minutes if $\Delta T \leq 10$ K 40 minutes if $\Delta T > 10$ K	Test pressure _____ bar maintain the test pressure of 11 bar, if necessary restore the test pressure regularly
Test pressure _____ bar if necessary restore the test pressure of 11 bar	
<input type="checkbox"/> Visual inspection on the entire drinking water installation, especially on the connection area completed and no leak detected.	<input type="checkbox"/> Visual inspection on the entire drinking water installation, especially on the connection area completed and no leak detected.
Test time _____ min (min. test time = 30 minutes)	Leak test
Pressure after 30 min _____ bar	Test pressure _____ bar (5.5 bar)
	Test time _____ min (120 min)
	Pressure after 120 min _____ bar

3. Comments

Entire water installation, especially joints, checked visually for leak-tightness and no leaks found.

The entire drinking water installation is leak-tight.

4. Confirmed

For the client: _____

For the contractor: _____

Date: _____

Attachments: _____

Appendix A8

Form: Pressure test for water application
(Test medium: air)



Pressure test record: REHAU RAUTITAN system (drinking water installation)

1. Project

Project Name: _____
 Client: _____
 Address/House No.: _____
 Post Code/Town/City: _____

2. Leak test

Test medium: Oil free pressure air Azote Carbon dioxide _____

2.1 Test pressure _____ mbar (150 hPambar =150 mbar)

2.2 Piping volume* _____ l

2.3 Adaptation time _____ min

2.4 Current pressure _____ mbar (150 mbar = 150 hPa)

2.5 Test time _____ min

2.6 Current pressure _____ mbar (150 mbar = 150 hPa)

Piping volume	Adaption time ¹⁾	Test time ¹⁾
<100 l	10 min	120 min
≥ 100 < 200 l	30 min	140 min
≥ 200 l	60 min	+ 20min per 100 l

¹⁾ Approx. values, depending on the piping volume

Visual inspection with leak detection agents on the entire drinking water installation, especially on the connection area completed and no leak detected.

3. Load test

3.1 Test pressure _____ bar (3 bar)

3.2 Current pressure after 10 min _____ bar

3.3 Comments:

Visual inspection with leak detection agents on the entire drinking water installation, especially on the connection area completed and no leak detected.

The entire drinking water is leak-tight.

4. Confirmed

For the client: _____

For the contractor: _____

Date: _____

*Approx. length of RAUTITAN pipe holding a volume of 100 l

Approx. pipe length in m	16 x 2.2	20 x 2.8	25 x 3.5	32 x 4.4	40 x 5.5	50 x 6.9	63 x 8.6
RAUTITAN PE-Xa pipe	943 m	613 m	393 m	236 m	151 m	97 m	61 m

Master copy, duplication permitted

REHAU Pty Ltd

National Customer Service Centre Tel: 1300 768 033

Fax: 1300 760 665

Email: sales.au@rehau.com

www.rehau.com.au

Sydney

Suite 1.02, Level 1, Quad 1,
8 Parkview Drive,
Sydney Olympic Park NSW 2127
Direct Dial: 02 8741 4500

Adelaide

REHAU Pty Ltd
113 Anzac Highway, Ashford
SA 5035

Melbourne

REHAU Pty Ltd
9-11 Endeavour Way, Braeside
VIC 3195
Direct Dial: 03 9586 3100

Perth

REHAU Pty Ltd
G11, 59 Albany Highway
Victoria Park
WA 6100
Direct Dial: 08 9355 5700

QLD

REHAU Pty Ltd
PO Box 8148, Woolloongabba
QLD 4102

**REHAU Ltd**

60B Cryers Road, East Tamaki 1701 Auckland, New Zealand

Tel: +64 9 272 2264 • Fax: +64 9 272 2265

Email: sales.nz@rehau.com

www.rehau.co.nz