



REHAU®

Unlimited Polymer Solutions



SEWER TECHNOLOGY - SAFETY FOR GENERATIONS

Technical Information: Maintenance Holes, Chambers, Shafts, Fittings



www.rehau.com.au
Valid from June 2018
Subject to technical modifications

For the latest installation instruction, technical information, design service and training/installation videos, visit www.myREHAU.com

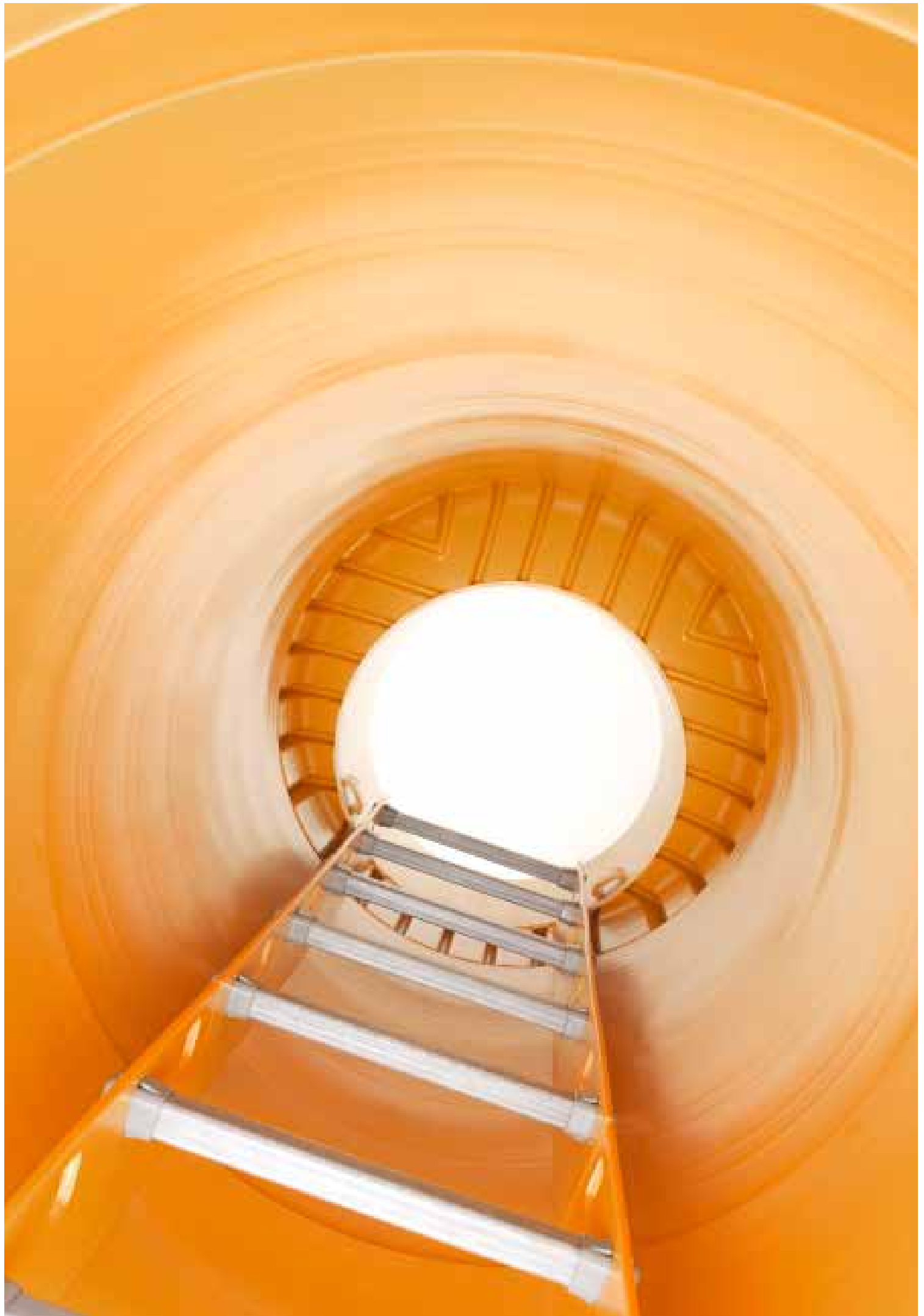

CONTENTS

Information and safety advice	4
AWASHAFT PP 1000 and 800	6
with polymer load bearing ring	
AWASHAFT PP 600	10
with telescopic adapter/concrete load bearing ring	
AWASHAFT PP 400/315	13
with DN/ID 300 and DN/ID 225 riser	
AWADUCT FLEX CONNECT	19
Universal adapter	
Installation instructions AWADOCK DN 160/200	35
for connection to AWASHAFT riser	

INFORMATION AND SAFETY ADVICE

NOTES ON THIS TECHNICAL INFORMATION

Validity

This Technical Information is valid for Australia.

This publication is valid from June 2018.

This publication supersedes the previous Technical Information books.

Navigation

At the beginning of this document you can find a detailed content page which lists the individual chapters and their respective page numbers.

Definitions

Definitions of the products are as per WSA 02 Gravity Sewerage Code of Australia and respective standards of the maintenance structure and fittings.

AWASHAFT System component

This Technical Information describes the components and requirements for the installation of REHAU AWASHAFT Maintenance Structure and AWADUCT and AWADOCK fittings.

Explanation of symbols



Safety information



Legal information



Important information, which needs to be taken into account



Information on the Internet



Your benefits/advantages



Latest Technical Information

For safe usage of REHAU products, please check regularly if a newer version of the technical information is available. The date of issue of your technical information can be found on the back cover in the bottom right hand corner. The latest technical information manuals are available from the REHAU sales office, appointed wholesalers as well as from our website:

www.rehau.com.au or www.rehau.co.nz.



Safety advice and operating instructions

- Please read these safety instructions and technical information carefully and completely for your own safety and other's before beginning the installations.
- Please keep this copy for your future reference.
- If you have any questions or need further clarification on the safety instructions and/or the individual installation instructions, please contact your nearest REHAU sales office. Refer to the last page for contact details.
- **Failure to observe the safety information/instructions can result in damage to property and persons.**

Intended use

The REHAU Maintenance structure systems and fittings should be designed, installed and operated in accordance to WSA 02, Gravity Sewerage Code of Australia and REHAU's Technical Information book. Any other use of the system is prohibited.

This document is copyright protected. The right of translation, reproduction, drawings, illustrations, broadcasting and rendering on photomechanical or similar means as well as storage in data processing systems are reserved. All measurements and weights are of approximate values. Errors and changes are to be expected.

Our verbal and written advice in regards to operation is based on years of experience and standardised assumptions and provided to the best of our knowledge. The intended use of REHAU products is described comprehensively in the Technical Information book. REHAU has no control over the application, use or processing of the products and responsibility remains entirely with the respective user/processor.



When installing the REHAU sewer technology products, please observe all applicable national and international regulations and local utility codes and specifications on approved products, Installation, testing, accident prevention and safety together with the information contained in this Manual.

Also observe the applicable laws, standards, guidelines and regulations (e.g. DIN, EN, ISO, WSA, WS, AS/NZS) as well as regulations on environmental protection, provisions of professional associations and regulations of the local public utility companies.

Any applications not described in this Manual - i.e. non-standard applications - must be discussed with our Technical Applications Department. For more detailed advice, please contact your REHAU Sales Office.

This design and installation information is related solely to the specific REHAU product. Occasionally, references are made to parts of applicable standards and directives. Always observe the current version of any guidelines, standards or directives.

Further standards, directives and guidelines related to the design, installation and operation of gravity sewer systems should also be referred to, but these do not form part of this Technical Information.



General safety measures

- Keep your workplace tidy and free of obstructions.
- Ensure there is always sufficient light.
- Keep children, pets and unauthorised persons away from tools and installation areas. This is especially important when carrying out refurbishment/repair work in occupied areas.
- Only use the corresponding components in the piping system that have been generally approved by REHAU. Using components which are not part of the system or tools which do not originate from the respective REHAU sewer technology products can lead to accidents or other hazards.

Trades qualifications

- Only authorised and trained persons are allowed to install REHAU systems.

Work clothing



- Wear PPE according to the safety requirements. Consider the safety requirements of working in a confined space when entering a maintenance structure.
- Wear eye protection, adequate work clothing, protective shoes, safety helmets, and a hairnet if you have long hair.
- Do not wear loose clothing or jewelry as these can be caught by moving parts.
- A safety helmet must be worn especially when carrying out installation work at face level or overhead.

Follow the installation instructions





- Read carefully and observe at all times the Operating Manual for the REHAU installation tool which is being used.
- Incorrect handling of tools can cause cuts, crush or sever limbs.
- When cutting the pipe to the desired length, keep a safe distance between the holding hand and the tool (pipe cutter).
- When cutting, do not reach into the cutting zone of the tool or near its moving parts.
- Keep your hands away from movable parts or the tools pressing area during jointing.
- Precautions should be taken when installing rubber rings.

Operating parameters

- If the operating parameters provided in Pages 6, 7 and 18 are exceeded, the pipes and joints may become overstrained. Not adhering to the operating parameters is thus not allowable.
- Keeping within the operating parameters must be ensured by safety control equipment (e.g. pressure reducers, safety valves, etc.)

Field of application		Gravity sewer systems	
General Designation		Maintenance Hole	
Description		AWASHAFT PP 1000	
Figure			
General properties	Nominal diameter of base [DN]	DN 1000	
	Man-entry	yes	
	Material	PP free of fillers. free of foaming additives and recycled materials	
	Maximum Installation Depth (Recommended)*	8 m (5 m)	
	Maximum traffic load	Up to SLW 60 (F900) / Class D	
	Buoyancy safety. maximum groundwater level above pipe bottom	5 m	
	Pipe connections (plug-in/weldable)	Rubber ring / welded connection	
	Tightness of the attached parts (pipe connection)	0.8 bar (2.4 bar)	
Standards/approvals	Minimum installation depth (Depending on the type of cover)	1.2 m	
	WSAA appraisal		
	Relevant standards fulfilled	DIN EN 13598-2. DIN EN 476	
Other test results/expert reports			
Material properties	Chemical resistance	pH 1 – 13	
	Temperature resistance	Long term	60 °C
		Short term	90 °C
	Recyclable	yes	
Advantages/Customer benefits	Resistant against ground water infiltration		
	Solid and load-bearing under high traffic loads (up to SLW 60 /Class D)		
	Buoyancy protection even at high groundwater levels		
	100 years design life		
	Premium injection moulding quality made from polypropylene		
	Flexible modular chamber system with integrated ladders		
	Easy inspection chamber concept for every application		

* For installations with greater depths contact REHAU sales office.

Maintenance Hole/Chamber	Maintenance Chamber	Maintenance Shaft	Terminal Maintenance Shaft
AWASHAFT PP 800	AWASHAFT PP 600	AWASHAFT PP 400	AWASHAFT TMS
			
DN 800	DN 600	DN 400	225
yes/no	no	no	no
PP free of fillers. free of foaming additives and recycled materials	PP free of fillers. free of foaming additives and recycled materials	Base: PP high modulus riser reducer: PVC-U according to AS/NZS 1260	PVC-U riser according to AS/NZS 1260
5 m (3 m)	5 m (3 m)	5 m (3 m)	5 m (3m)
Up to SLW 60 (F900) / Class D	Up to SLW 60 (F900) / Class D	Up to D 400 / Class D	Up to D400/Class D
5 m	5 m	3 m	3 m
Rubber ring joint / welded joint	Rubber ring joint / welded joint	Rubber ring joint	Rubber ring joint
1 bar (2.4 bar)	0.5 bar (2.4 bar)	0.5 bar (0.5 bar)	0.5 bar (0.5 bar)
1.1 m	1 m	0.9	0.9
+	+	+	+
WSA 137, WSA 02, EN 13598-2, EN 476	WSA 137, WSA 02, EN 13598-2, EN 476	WSA 137, WSA 02, EN 13598-2, EN 476	AS/NZS 5065, WSA 02
pH 1 – 13	pH 1 – 13	pH 1 – 13	pH 1 – 13
60 °C	60 °C	40 °C	60 °C
90 °C	90 °C	60 °C	90 °C
yes	yes	yes	yes
Ideal for rehabilitation of the existing concrete manholes	Cost effective due to the size	Ideal as a building inspection chamber for land drainage	.
Solid and load bearing under high traffic loads (up to SLW 60/ Class D)	Long service life: Corrosion resistant PP extends the service life	Fast and easy to install via variable single components	.
Buoyancy safety even at high groundwater levels	Safe and inspection-friendly with the colour orange	Can be installed without expensive equipment	.
Long service life and leak-proof	Easy site handling. Lower labour and equipment costs due to light weight and quick installation	Problem-free insertion of inspection testing and cleaning equipment	.
Easy to inspect and safe		Long service life and leak proof	.
Cost effective due to the size			.
Can be perfectly combined with DN 1000			.

TRANSPORT AND STORAGE

Chambers and fittings

Transport

In order to maintain the integrity of AWASHAFT maintenance structure as well as fittings, they must be stored properly and transported with care. Components must be secured during transportation against movement to prevent deflection or impact stresses.

Bundled riser pipes

Suitable equipment should be used for loading and unloading bundled riser pipes (e.g. fork lifts with wide forks). The forks must not damage the components during unloading and transport.

Loose AWASHAFT components and fittings

Loose AWASHAFT components and fittings have to be loaded and unloaded manually. Tipping or throwing is not permitted. Dragging components over the ground should be avoided. Grooves and scratches can damage the connections and result in leakage in joints. Components must be checked carefully when they are delivered and immediately before they are installed to ensure that they show no signs of damage.

Storage

All materials should be protected from chemical contamination or physical damage. This particularly concerns elastomeric sealing agents, which are to be protected against mechanical and chemical attack (e.g. oil).

Components are to be secured to avoid damage by rolling away. Components must be protected against UV radiation.



Excessively high stack heights should be avoided to prevent overloading the components in the lower section of the stack. Longitudinal deflections should be avoided. All components should be stored so that contamination of the socket area is avoided. Unilateral effects of heat, e.g. the sun's rays can lead to deformation due to the thermoplastic behaviour, which may make it difficult for components to be installed properly. For this reason, the components should be protected against direct sunlight, e.g. by covering them with light tarpaulins.

Heat accumulation must be avoided. Care should be taken to ensure that there is good ventilation. Fading or discolouration caused by storage in the sun has no adverse effect on the quality of PP material. Local whitening or brightening on the inside of maintenance structure and fittings may indicate external short-term point loads or impact stress. However, these occurrences do not affect the stability or service life.

If longer-term outdoor storage is required, products must be wrapped with suitable UV protection wrap and seals should be checked for perfect condition before the installation. If necessary, the seals should be replaced with new seals.

INSTALLATION INSTRUCTIONS AWASHAFT PP 1000 AND 800 with polymer load bearing ring



1 The bedding of the base should be prepared as per AS/NZS 2566.1 and 2 and the water utility specifications. A minimum of 10 cm thick bedding layer (e.g. granular subbase) is required.



4 Connect the inlet pipe to the fitting and align the pipe according to the plans. The ball joint/Double socket vario can utilise the slope changes as well as changes in direction up to 7.5° in every direction.



2 Position the chamber base according to the plans and align the inlet(s) and outlet. In case of bases with gradient, note the direction of the slope. Connect the outlet of the base to the pipe (*).

* Push-fit connection: clean the already chamfered and de-burred spigots and apply lubrication. Check the seals are correctly positioned. Clean off dirt before connection. Fully Insert the spigot end into the socket.

Note on installing the Double socket vario:

The double socket vario should be inserted to the base from the fully variable side. Also, ensure that the soffit marking is pointing upwards (refer to the sketch below). Follow the instruction guides provided in the package.

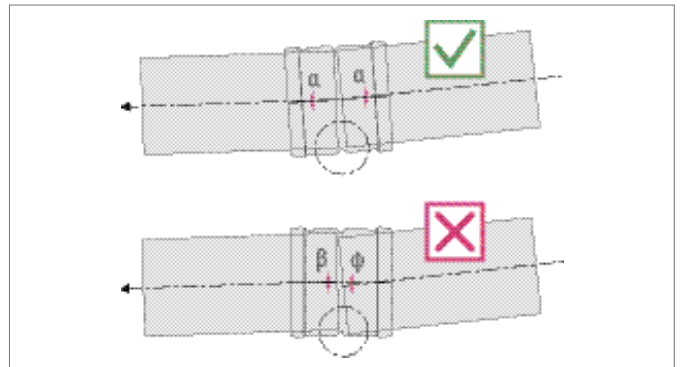

3 Connect ball joint/Double socket vario to the inlet(s) of the base noting the direction of the flow. Refer to the installation instruction of the ball joint/Double socket vario included in the package (arrows on the ball joint show the direction of the flow). Stabilise the fitting using bedding material.





5 To insert the element seals, first clean and lubricate the recess between the top set of ribs as shown in the photo above. Then insert the element seal with the lettering pointing upwards. Finally check for any damage, correct positioning and dirt.

Tip: For easier lifting of the base, risers and cones, lifting lugs are provided on the components.

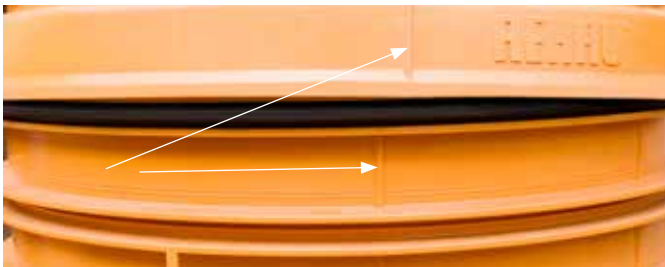

7 To stabilise the base and element rings fill the surroundings with soil group G1 or G2, max. particle size 63mm (stepped soil with fine particles) up to a point that cone can be installed. Recommendation: Use recycled material. Add back-fill material at a width of 40 cm (for installation in ground water min. 60 cm) in 20-40 cm thick layers and compact according to the requirements of AS/NZS 2566.1 and 2566.2. Degree of compaction in areas with vehicular load: DPR \geq 97%.

6 Clean and lubricate the inside of the skirt in the riser ring. Position the rings on top of the base. Align the ring and base using the two vertical marks. Follow to the same instructions for installing the rest of the riser rings.

Note, in case of AWADOCK connection to riser, when selecting and arranging the riser rings, consider the position of the riser connection. AWADOCK can only be installed in a riser ring and it can not be installed at the connection of riser rings. (see AWADOCK installation guide)

Tip: do not lubricate the element seal when installing the rings and cone.





8 Install cone, add backfill material in layers and compact according to points 5, 6 and 7.



9 The chamber cone can be shortened on-site to max. height of 25cm to suit the height. See sketch on page 12 for the correct shortening height. Trimming should be carried out in line with the ribs. Ribs are spaced at 1 cm intervals. Deburr the cut edge.

The back fill should be added up to 5 cm below the upper edge of the trimmed cone installation sketch on page 12. The bedding must be level so the load is transmitted uniformly from the load bearing ring to the backfill material. (adjust backfill or add a thin concrete blinding layer if necessary).



10 Fit the cone seal DN 625 to the top of the shortened cone.

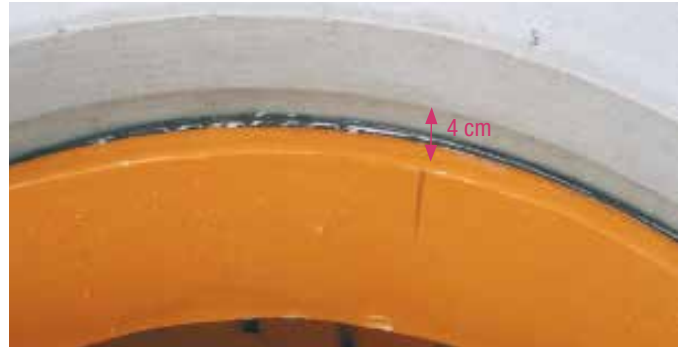

11 Coat the inside of the load bearing ring with lubricant and then mount centrally and evenly on the bedding to avoid any point loads. Direct contact between the load bearing ring and the cone should be avoided. There should be a approx. 4 cm vertical space between the load bearing ring and the cone (see the installation sketch on page 11) to ensure after any potential settlement of the road, the traffic load is not transferred to the chamber.

Note, cover the top of the load bearing ring during the road building phase.



12 Mount the cover on a 1cm leveling mortar to avoid point loads on the load bearing ring.

Installation sketch for AWASHAFT 800 and 1000 with Class B and Class D access covers.

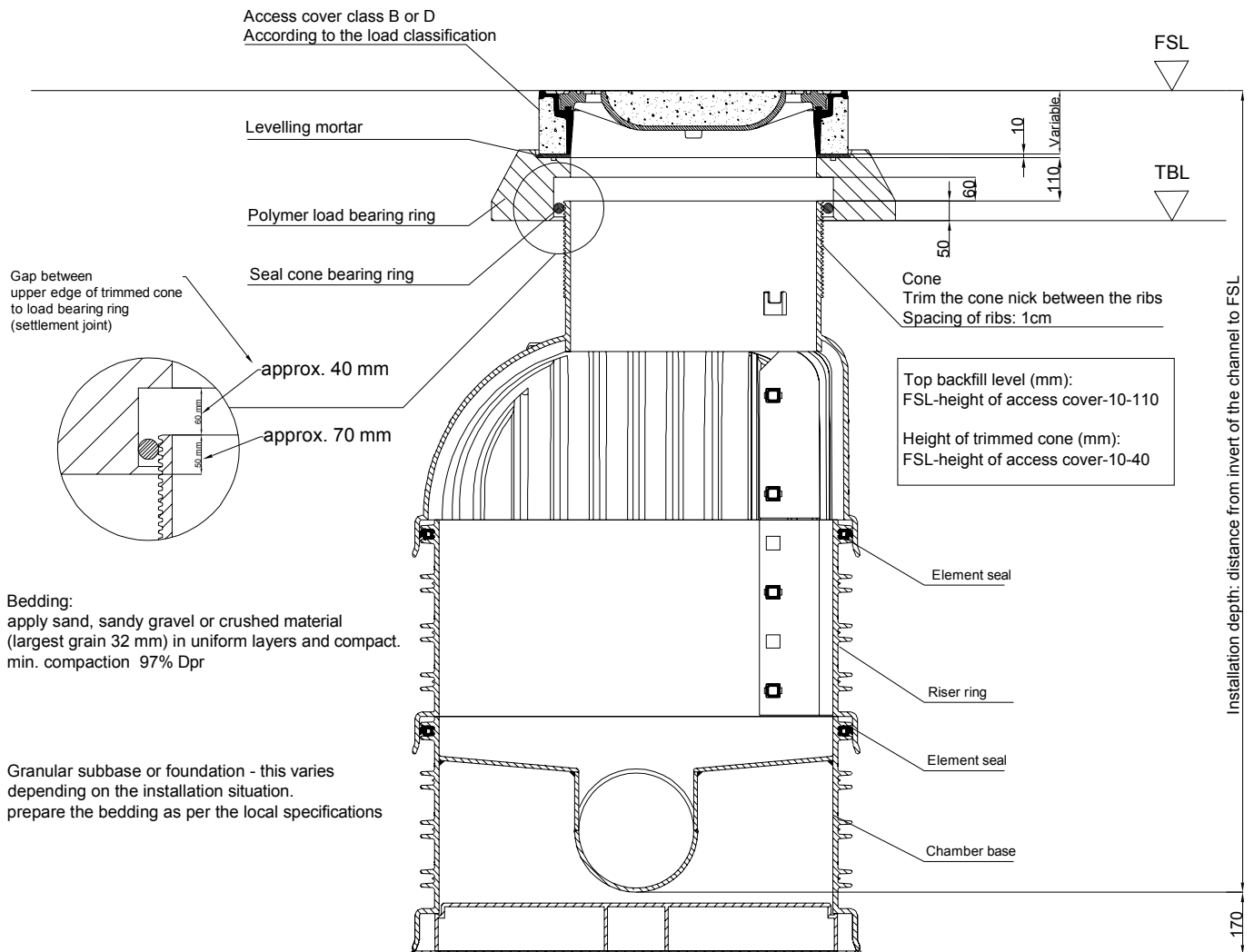

* AWASHAFT 800 as a Maintenance Chamber shall be installed as a non man entry maintenance structure. Some utilities require a restriction in clear opening to 300 mm which can be achieved by installing a suitable access cover.

INSTALLATION INSTRUCTIONS AWASHAFT PP 600

with polymer load bearing ring



1 The bedding of the base should be prepared as per the water utility specifications. A minimum of 10 cm thick bedding layer (e.g. granular subbase) is required.



4 Connect the inlet pipe to the fitting and align the pipe according to the plans. The ball joint/Double socket vario can utilize the slope changes as well as changes in direction up to 7.5° in every direction (slope changes up to 13%).



Note on installing the Double socket vario:

The double socket vario should be inserted to the base from the fully variable side. Also, ensure that the soffit marking is pointing upwards (refer to the sketch below). Follow the instruction guides provided in the package.

2 Position the chamber base according to the plans and align the inlet(s) and outlet. In case of bases with gradient, note the direction of the slope. Connect the outlet of the base to the pipe (*).

Push-fit connection: clean the already chamfered and de-burred spigots and apply lubrication. Check the seals are correctly positioned and clean of dirt before connection. Fully Insert the spigot end into the socket.

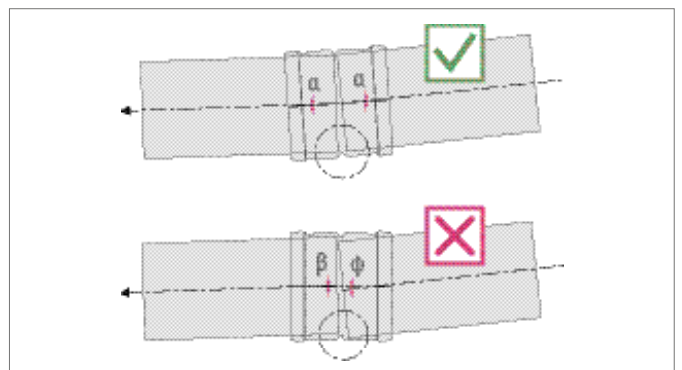

3 Connect ball joint/Double socket vario to the inlet(s) of the base noting the direction of the flow. Refer to the installation instruction of the ball joint/Double socket vario included in the package. Stabilise the fitting using bedding material.



5 Check if the chamber is correctly leveled.



6 To insert the element seals, first clean and lubricate the recess between the bottom set of ribs as shown in the photo above. Then insert the element seal. Clean and lubricate the inside of the base and push the riser into the base.
In order to increase the height of riser, DN 600 double socket can be installed (refer to the product book).



9a Insert the elastomeric seal on the outside of the riser on the recess between the two top ribs and install the load bearing ring noting an overlap of 70 to 90 mm.
It is important that the load bearing ring is decoupled from the riser and load bearing ring is sitting uniformly on the bedding to avoid any point load. Use leveling mortar to adjust the height with road level and install class D access cover on top of the mortar.



7 To stabilize the base and ring fill the surroundings with soil group G1 or G2, max. particle size 16mm (Graded soil with fine particles). Recommendation: Use recycled material. Add back-fill material at a width of 40 cm (for installation in ground water min. 60 cm) in 20-40 cm thick layers and compact according to the local requirements. Degree of compaction in road areas: $DPr \geq 97\%$

a) Installation in Class D area



8a add the backfill and prepare the surrounding of the riser. Cut the riser to the correct height according to the plans. When cutting the riser, note the riser should overlap with the load bearing ring between 70 to 90 mm. Ensure the cut is made on the crest of the corrugation. One complete recess between the top ribs should be available for insertion of the elastomeric seal.
The cut surface should be deburred.

b) Installation in Class B area

8b The telescopic part can accommodate 30 cm of height adjustment on site. The riser pipe can be shortened noting the height adjustment by telescopic part.



9b The seal for the telescopic pipe part should be mounted on the inside of the riser pipe between the first and second corrugation. Lubricate the seal and insert the telescopic part to the required height according to the plans.

Note: telescopic part should be inserted into the riser pipe a minimum of 14 cm.

Prepare the surrounding soil according to the local requirements and to the correct height (see installation sketch on page 15). Telescopic part will sit on the surrounding soil. Install and seal the access cover on top of the telescopic part using polymer mortar.

Installation sketch for AWASHAFT 600 with Class B access covers.

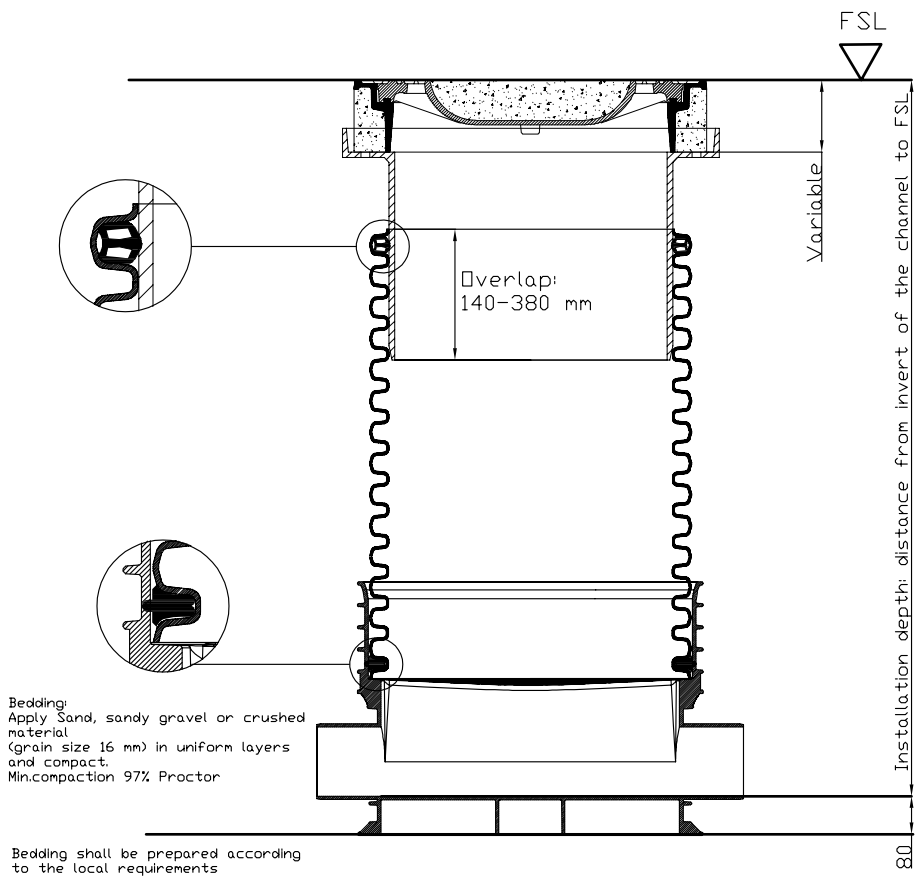

Installation sketch for AWASHAFT 600 with Class D access covers

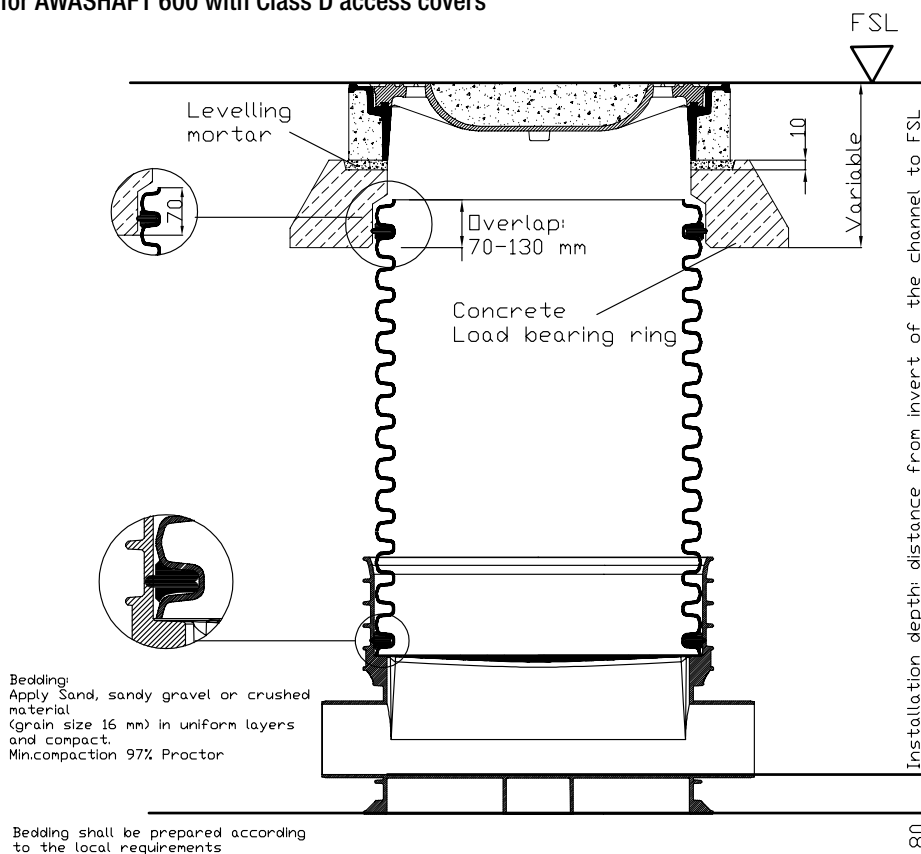

* AWASHAFT 600 Maintenance Chamber shall be installed as a non man entry maintenance structure. Some utilities require a restriction in clear opening to 300 mm which can be achieved by installing a suitable access cover.

INSTALLATION INSTRUCTIONS AWASHAFT PP 400

With connection to DN/ID 300 and DN/ID 225 riser



1 The bedding of the base should be prepared as per the water utility specifications. A minimum of 10 cm thick bedding layer (e.g. granular subbase) is required.

2 Insert reducer DN/OD 400/315 (DN 375/300) into DN 400 chamber base and align the offset of the eccentric reducer in line with the centre of the outlet to give provide maximum access for inspection and maintenance tools.

In case of DN225 riser, install the reducer DN/OD 315/250 (DN 300/225)

3 Position the chamber base according to the plans and align the inlet(s) and outlet. Connect the outlet of the base to the pipe (*).

* Push-fit connection: clean the already chamfered and de-burred spigots and apply lubrication. Check the seals are correctly positioned. Clean off dirt before connection. Fully Insert the spigot end into the socket.

4 Connect ball joint to the inlet(s) of the base noting the direction of the flow. Refer to the installation instruction of the ball joint. Stabilise the fitting using bedding material.

5 Connect the inlet pipe to the fitting and align the pipe according to the plans. The ball joint can utilize the slope changes as well as changes in direction up to 7.5° in every direction. In the event the angle is more than 7.5, long radius bends may be used according to the local codes.

6 Block unused inlet branches with plugs. The plugs should be secured in place as specified by the local water utility codes. Some methods include:

- Placing a bag of dry premix concrete or cement in front of the plug.
- Placing a wet concrete mix in front of the plug.
- Placing a metal or wooden stake/peg in front of the plug.



7 Check if the chamber is correctly leveled and add fine bedding material layer by layer to a minimum cover of 100 mm above chamber base.



8 Chamfer and deburr the riser pipe and insert the riser to the reducer from the chamfered end using lubrication. (*)

9 Add the back fill in layers and compact according to local water utility specifications.

10 Cut riser pipe 100 mm below finished surface level and install PVC-U push-on /solvent weld-on cap with screw lid. Install high frame access cover according to the load classification (ensure access cover is not attached to the cap with lid).

Installation sketch for AWASHAFT 400

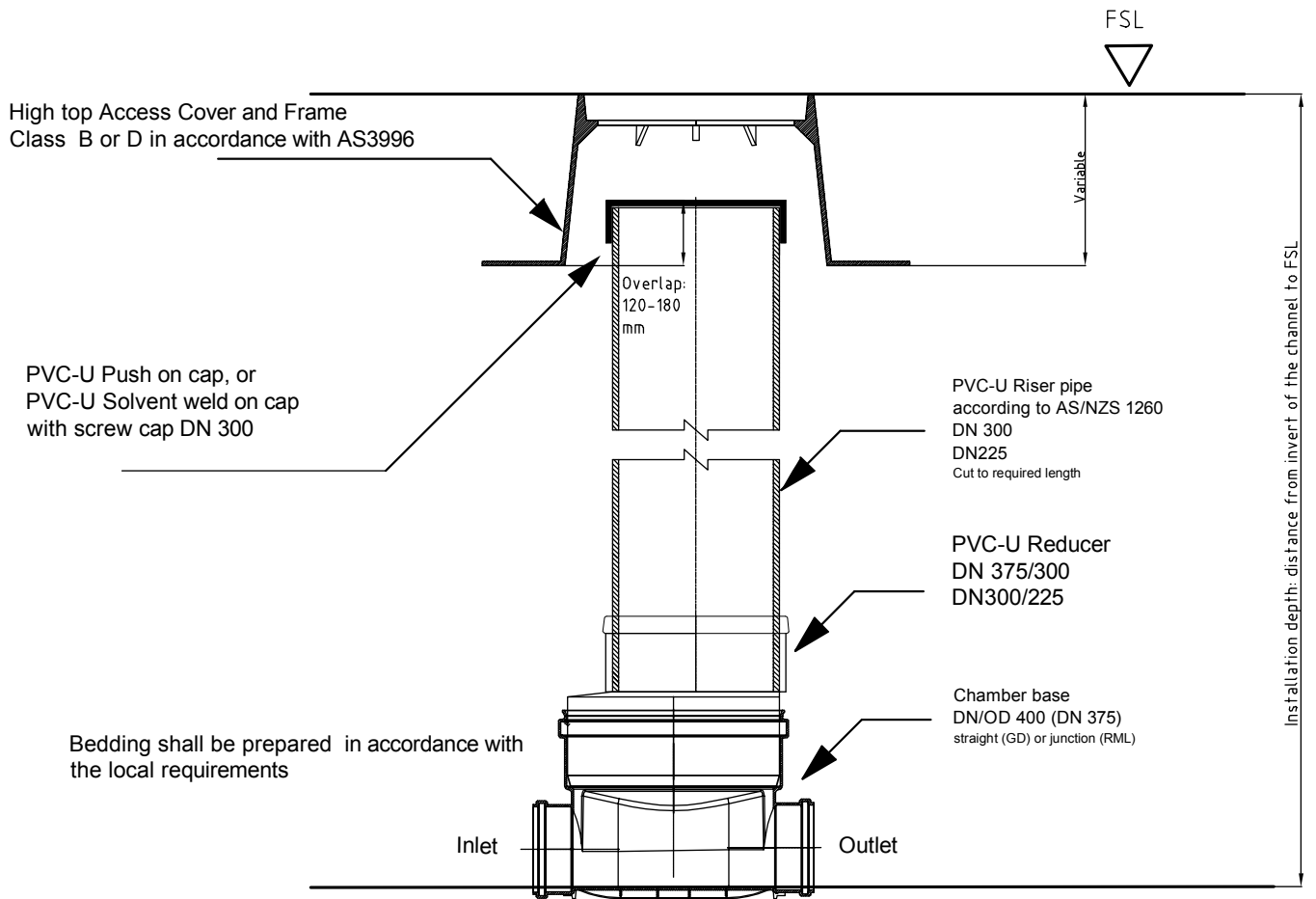

APPLICATIONS / OVERVIEW OF TYPES

Fitting systems

Designation	AWADUCT Flex connect	AWADUCT/AWADOCK PP
Standards/approvals		
Relevant standards	AS/NZS 4327 EN 295-4	AS/NZS 5065 EN 1852
Data/properties		
Material	PP, EPDM, Q-TE-C	PP
Average density [g/cm ³]		0.9
Colour	Orange, Black, Silver	Orange
Jointing technique	Rubber ring	Rubber ring joint
Properties		
Short-term modulus of elasticity [N/mm ²]	>=1100	1700
Chemical resistance*	PH 1-13	PH 1-13
Impact strength	++	++
Maximum wastewater temperatures [°C]	Permanent load	60
	Short-term	90
Usual slope range [‰]	2-200	2-200

++ +
Very good

* The pH values represent a guidance value, the chemical resistance, among other things, also depends on the temperature and type of medium
If you have any queries, please contact our REHAU specialist adviser.



AWADUCT FLEX-CONNECT

Universal connection system

AWADUCT FLEX-CONNECT

The universal pipe coupler



Up to **20 %** greater insertion depth
ensures a reliable connection

Up to **75 %** fewer variants
in comparison to conventional pipe couplers,
meaning lower warehousing costs

Clamping range of **110 – 695 mm**
with only 9 types



"Airbag seal" made of **Q-TE-C**
as secondary seal

Tested leak-tightness up to **2.5 bar**
Certified by external testing institute

THE PIPE COUPLER FROM REHAU

One coupler for all applications

Irrespective of the material, surface texture, wall thickness and outside diameter, pipes can be joined with one another very quickly thanks to the easy and fast assembly. A wide range of applications are covered by only a few variants of AWADUCT flex connect.

AWADUCT FLEX-CONNECT connects pipes ...

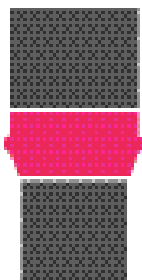

... of different outside diameters

The individual types of AWADUCT FLEX-CONNECT have an extra-large clamping range. The clamping range describes the smallest and largest possible outside diameter that can be connected by a pipe coupler. AWADUCT FLEX-CONNECT offers a flexible solution for clamping ranges between 110 and 695 mm:

With only 9 product variants, almost every application can be covered.

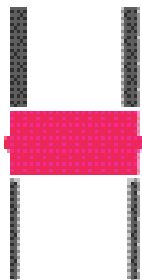

... of different wall thicknesses

The pipes are joined centrally. This means that pipes having the same inside diameter can be joined with one another irrespective of their wall thicknesses. In the event of large inside diameter differences, the step of invert can be reduced by using off-centre compensating rings or eccentric adapters.

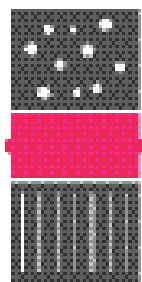

... of different materials

AWADUCT FLEX-CONNECT can be used for pipes of various materials:

- GRP pipes
- PP pipes
- concrete and fibre reinforced concrete pipes
- vitrified clay pipes
- PVC pipes
- fibre reinforced cement pipes
- SML pipes
- cast iron pipes
- PE pipes

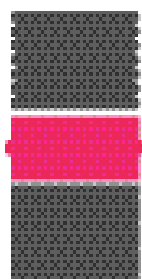

... of different surface textures

Irrespective of the surface texture,

- smooth pipes
 - ribbed pipes
 - and corrugated pipes
- can be connected.

AN ASSEMBLY THAT SAVES TIME AND MONEY

Universal. Safe. Cost-effective.



Slip on



Tighten



Finished

The easy and fast assembly saves time and money. The reliable joint quality is ensured by extra-large insertion depths. In addition, for all eventualities, the swelling secondary seal made of Q-TE-C offers additional safety and permanently seals leakages.

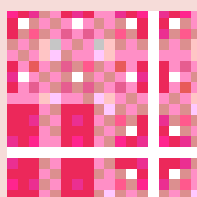

Up to **75 %**
less variants
compared with conventional
standard couplers

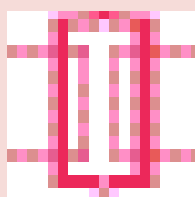

Up to **20 %**
greater insertion depth
compared with conventional
products

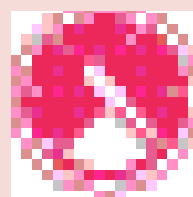

Up to **2.5 bar**
tested leak-tightness
and additional safety thanks to
the "airbag seal" from Q-TE-C

REHAU INNOVATIONS 2017

AWADUCT FLEX-CONNECT: expansion of the accessories range

Accessory part: compensating ring

If the outside diameters of two pipes greatly differ, a compensating ring may be used. With every compensating ring, the outside diameter is increased by approx. 22 mm by simply stretching the ring over the pipe. With up to 3 compensating rings, the clamping range can therefore be increased by approx. 66 mm. The compensating ring can be used from DN/OD 300.



Clamping ranges of the AWADUCT FLEX-CONNECT types

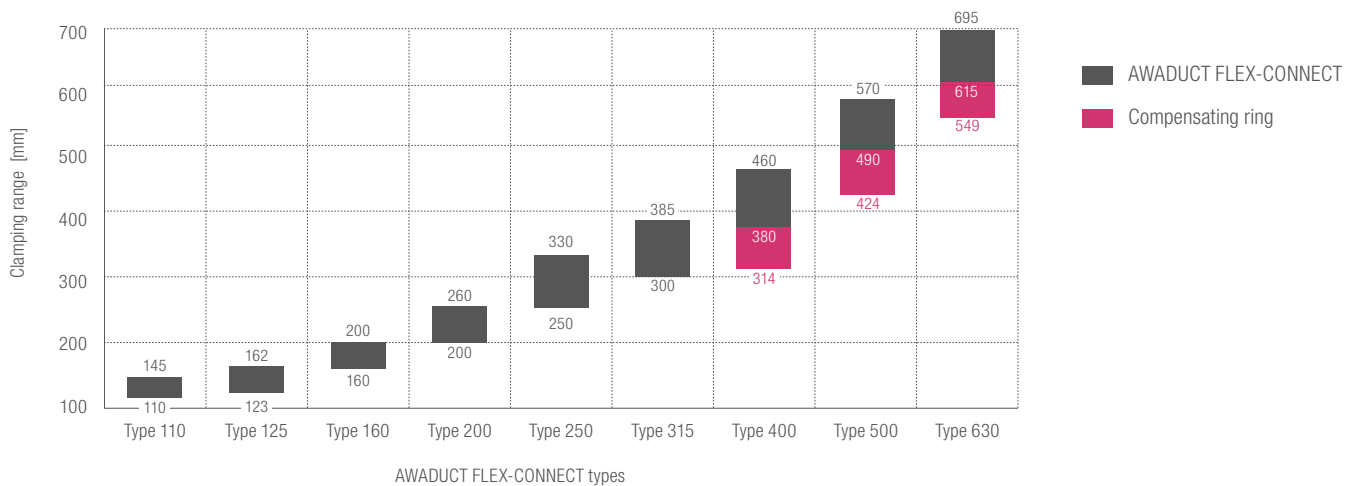

Assembly example

The following pipes need to be joined:

- vitrified clay pipe DN 500, outside diameter 581 mm
- concrete pipe DN 500, outside diameter 670 mm

Solution:

- AWADUCT FLEX-CONNECT type 630 + 2 compensating rings

In order to be able to join the vitrified clay pipe with an AWADUCT FLEX-CONNECT type 630 (615 – 695 mm) 2 compensating rings are required. The outside diameter (OD) will therefore be increased from 581 mm to 625 mm.

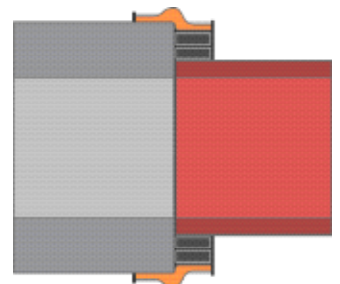

Selecting the first compensating ring:

- outside dia. of vitrified clay pipe: 581 mm
- selection from table → compensating ring 549 - 599 mm (mat.no. 14098171001)
- new OD: 581 mm + 22 mm = 603 mm (outside the clamping range of the type 630 AWADUCT FLEX-CONNECT)

Selecting the second compensating ring:

- OD (vitrified clay pipe + 1 compensating ring) = 603 mm
- selection from table → compensating ring 600 - 649 mm (mat.no. 14098181001)
- new OD: 603 mm + 22 mm = 625 mm (within the clamping range type 630)

A connection with AWADUCT FLEX-CONNECT type 630 is readily possible.

Please note: To select the second compensating ring, the overall diameter of the pipe and the first compensating ring should be considered.



Accessory part: Eccentric Adapter Ring (EAR)

If pipes with different inside diameters are joined, a step (step of invert) may incur between the two pipes. The step can be clearly reduced by using an Eccentric Adapter Ring (EAR).

The standard DIN EN 476 define Pipe joints up to DN/OD 315 or DN/ID 300 are not permitted to exceed a step of 6 mm (corresponds to an inside diameter difference of 12 mm).

When joining a polymer pipe to pipes made from different materials, it is advisable to use an EAR if the difference of the inside diameters exceeds 12 mm. Detailed information can be found in chapter "Technical information for connection and jointing systems" on page 28.



Assembly example

The following pipes need to be joined:

- PP pipe DN/OD 200, ID 183 mm
- vitrified clay pipe DN 200, ID 205 mm
- inside diameter difference: 22 mm / step: 11 mm

Solution:

- AWADUCT FLEX-CONNECT type 200 + EAR 200

In case of a concentric connection, the inside diameter difference of 22 mm results in a step of 11 mm.

By using an EAR, the step will be reduced so that DIN EN 476 will be met.

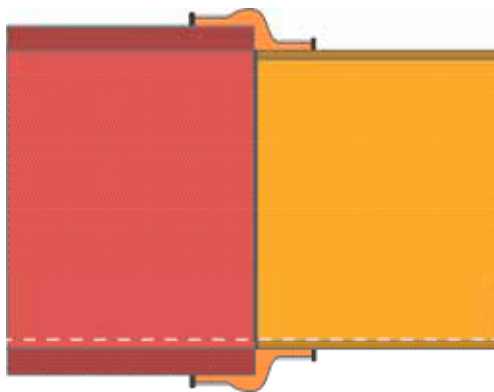

Connection without EAR - step of invert exists

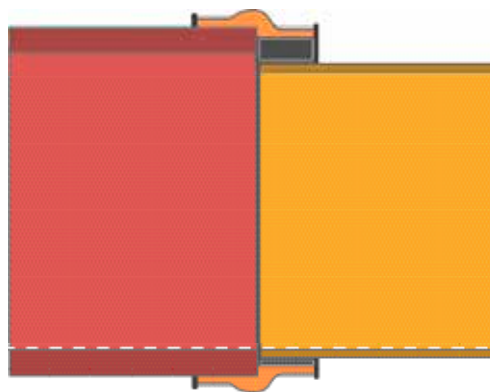

Connection with EAR - reduced step of invert

Typical application cases

Pipe 1	Pipe 2	Jointing
PP DN 200	Vitrified clay DN 200	Flex-Connect type 200 + EAR 200
PP DN 250	Vitrified clay DN 250	Flex-Connect type 250 + EAR 250
PP DN 315	Vitrified clay DN 300	Flex-Connect type 315 + EAR 315
PP DN 200	Concrete DN 200	Flex-Connect type 200 + EAR 200
PP DN 250	Concrete DN 250	Flex-Connect type 250 + EAR 250

ASSEMBLY INSTRUCTIONS AWADUCT FLEX-CONNECT

DN 110 to DN 630



- 1 Tightening bands made from stainless steel
- 2 Green swellable "Airbag seal" made from Q-TE-C
- 3 Sealing sleeve made from EPDM
- 4 Flexible support pipe made from RAU-PP segments

1 ASSEMBLY INSTRUCTIONS AWADUCT FLEX-CONNECT



Installation instructions:

Ensure cleanliness during assembly work!

- The AWADUCT FLEX-CONNECT pipe coupler with the "airbag seal" made of Q-TE-C is to be stored protected from moisture until immediately prior to the installation in order to avoid unintentional swelling of the Q-TE-C
- Check that your AWADUCT FLEX-CONNECT set is complete: couplers consist of a black sealing sleeve, orange segment ring, 2 stainless steel tightening bands and lubricant
- If it is necessary to remove the tightening bands, they have to be installed in such a way that the tightening band end positioned at the bottom is always located in the overlapping direction of the segments to prevent the tightening band ends from slipping underneath the segments
- It has to be ensured that the loose tightening band end (end without tightening jack) does not slip between the tightening jack and the corresponding tightening band end
- Prior to the assembly, it is to be ensured that the outer diameters of the pipes to be connected are within the tightening range of the coupler. The tightening range is stated on the label
- Screw as slowly as possible if using a cordless screwdriver, however, at the most just before the sleeve makes contact with the pipe

Mat.no.	Type	Clamping range mm	Insertion depth mm
11024181001	110	110-145	85
11054201001	125	123-162	85
11024191001	160	160-200	85

11024231001	200	200-260	105
11024241001	250	250-330	105
11024251001	315	300-385	105
11024261001	400	380-460	130
11024271001	500	490-570	130
11024281001	630	615-695	130



Maintain a clean environment! No dirt must enter the tightening jacks.



Please note:

- The excavation pit must be installed, backfilled and compressed in compliance with **DIN EN 1610**
- For ribbed, corrugated or profiled pipes, it has to be ensured that the relevant ribs, corrugations or lugs do not get deformed during assembly as sufficient compression and permanent leak-tightness cannot be ensured
- Prior to the laying/assembly of AWADUCT FLEX-CONNECT at temperatures below 0 °C, we recommend storing the pipe coupler at room temperature to avoid compromising the functionality.

1.1 Information for assembly of AWADUCT FLEX-CONNECT type 110 - 200



Please note:

For assembling AWADUCT FLEX-CONNECT of dimensions < DN 250, you require the following tools for tightening and fixing the tightening bands:

- torque wrench (10 - 25 Nm)
- 8 mm socket and wrenches



1



2



3



4

1 The insertion depth is stated on the label or it can be determined by measuring the distance to the lip protruding in the centre.

2 The insertion depth must be marked onto both pipes.

3 Then apply a thin layer of lubricant to the spigot ends up to the mark.

Important: By alternately drawing both tightening bands together, adjust the pipe coupler to roughly the larger pipe diameter.

4 Push the pipe coupler onto the larger pipe up to the mark. When creating the connection, ensure that the tightening jacks are easily accessible.



5



6



7



8

5 Once the sleeve is positioned on the pipe, it is essential to use a torque wrench.

6 Slightly tighten the tightening band on the larger pipe so that the pipe coupler can still turn easily on the pipe.

7 Then insert the smaller pipe up to the mark.

8 Tighten the tightening jack on the smaller pipe with 15 Nm.



9



10

9 Then tighten the turnbuckle on the larger pipe at 15 Nm.

10 Finished.

1.2 Information for assembly of AWADUCT FLEX-CONNECT type 250 - 630



Please note:

- For assembling AWADUCT FLEX-CONNECT at dimensions \geq DN 250, you require the following tools for tightening and fixing the tightening bands:
 - REHAU tightening tool
 - Hexagon socket screw key 4 mm
 - Hexagon socket screw key 8 mm
 - Torque wrench (10 - 25 Nm)



- 1 Tip
- 2 Tightening lever
- 3 Carriage (on front stop)
- 4 Bracket
- 5 8 mm hexagon socket screw
- 6 Thread



- 1 The insertion depth is stated on the label.
- 2 The insertion depth is to be marked on both pipes.
- 3 Then apply a thin layer of lubricant to the spigot ends down to the mark.
- 4 For type 400 – 630: Remove the support pipes from the pipe coupler.



- 5 Push the pipe coupler onto the larger pipe up to the mark. When creating the connection, ensure that the turnbuckles are easily accessible.
- 6 For assembling AWADUCT-FLEX-CONNECT pipe couplers from type 250, you require the tightening tool shown.
- 7 Push the carriage of the tightening tool to the front by turning (left) the 8 mm hexagon socket screw in the tool handle.



8



9



10



11

8 Ensure that the tightening band jack is within the area between the flap and the tightening band end.

9 Press the tightening lever upwards and insert the tightening band into the tightening tool on the side or from the front.

10 The front on the tightening tool is positioned directly on the slot of the jack. Close the tightening lever.

11 Open the 4 mm hexagon socket screw of the tightening band jack.



12



12



13



14

12 Attach the tightening tool flat (tangentially) onto the pipe coupler. If at least one of the two pipes to be connected is positioned not more than 20 mm above the minimum clamping range, both sides of the pipe coupler must be reduced to about the larger pipe diameter by alternate tightening. Tighten the band by turning (right) the 8 mm hexagon socket screw in the tool handle so that the pipe coupler can still turn easily on the pipe. Tighten the 4 mm hexagon socket screw of the tightening band jack.

If the pipe coupler does not yet adhere to the pipe during the first tightening, carry out step 12.

13 Turn the 8 mm hexagon socket screw in the handle to the left until approx. 80 mm of thread on the rear tool end are exposed.

Open the clamping lever and push the carriage over the tightening band to the front. Close the tightening lever. Open the tightening jack screw, retighten the band (steps 10 and 11). Close the tightening jack screw.

14 Press the tightening lever upwards and remove the tightening tool.



15



16



17



18

15 Now insert the smaller pipe up to the mark.

16 Carry out steps 7 – 12 on the smaller pipe.

17 Tighten the tightening band, while the tightening jack screw is open, on the end of the tightening tool using the torque wrench using a torque of 12 Nm. **Important:** Ensure that the carriage does not adhere to the rear stop.

18 Tighten the tightening jack screw and release the tightening tool by opening the tightening lever.



19



20



21



22

19 Bend the excess tightening band down directly behind the tightening jack so that it makes contact with the pipe coupler.

20 Alternatively, the excess tightening band can be cut off. Press the bow downwards during this process. Then release the tightening tool.

Important: Observe the possible burr on the cut edge!

21 Now tighten the tightening band of the larger pipe with 12 Nm as previously described for the smaller pipe.

Important: Ensure that the carriage must not adhere to the rear stop either.

22 Finished.

2 ECCENTRIC ADAPTER RING (EAR)

2.1 When is an EAR required?



Off-centre compensating ring for pipes to reduce any potential shoulder (step of invert) when connecting pipes of varying inside diameters.



Standard DIN EN 476 "General requirements for components used in discharge pipes, drains and sewers" stipulates the following: Pipe joints up to DN/OD 315 or DN/ID 300 are not permitted to exceed a step of 6 mm (corresponds to an inside diameter difference 12 mm).

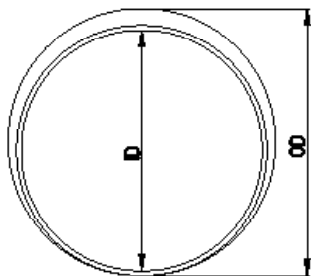

For this reason, when connecting polymer pipes (e.g. PP conforming to AS/NZS 5065) to pipes of other materials, we recommend the use of the EAR if the difference in the inside diameter of both pipes is greater than 12 mm.

Pipe joint with AWADUCT FLEX-CONNECT	Use of the EAR if the inside diameter difference ID (pipe X) - ID (polymer pipe):	
Type 200 (200 to 260 mm)	≤ 12 mm no EAR required	12-26 mm with EAR 200
Type 250 (250 to 330 mm)	≤ 12 mm no EAR required	12-32 mm with EAR 250
Type 315 (300 to 385 mm)	≤ 12 mm no EAR required	12-26 mm with EAR 315

Mat.no.	Type	ID mm	OD mm
14048261001	EAR 200	200	222
14048271001	EAR 250	250	278
14048281001	EAR 315	315	339

2.2 Example installation with EAR

For example, a vitrified clay pipe DN 200 is supposed to be connected to a PP pipe DN 200 using AWADUCT FLEX-CONNECT type 200. The vitrified clay pipe has an inside diameter of 205 mm. The PP pipe has an inside diameter of 183 mm. This results in an inside diameter difference of 22 mm. The resulting shoulder with a centric joint would correspond to 11 mm, making the use of an EAR advisable. This means that the step can be reduced considerably for conformity with DIN EN 476.

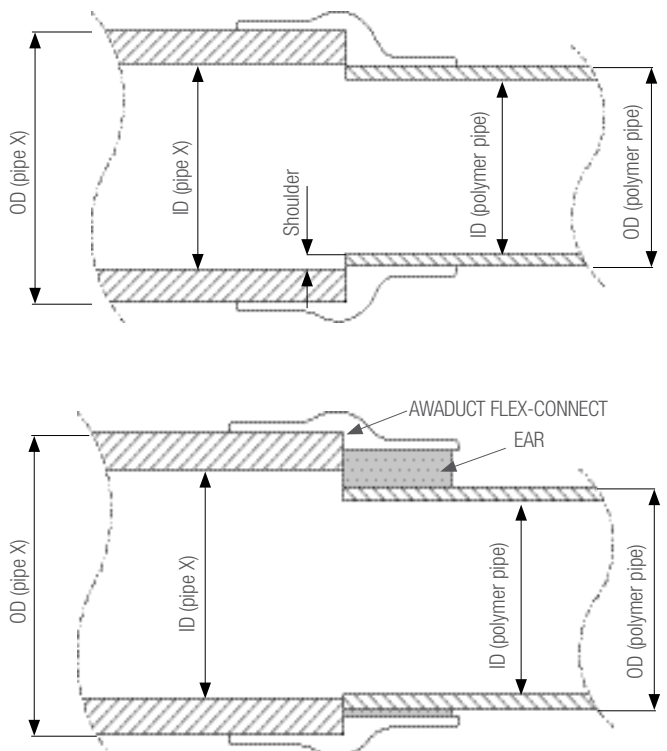

2.3 Information for assembly of AWADUCT FLEX-CONNECT with EAR

Assembly with EAR in order to reduce the step of invert



1 The EAR is pushed onto the polymer pipe as far as the stopper lip on the EAR, where necessary using silicone-free lubricant. The inside diameter of the EAR is designed for PP pipes according to AS/NZS 5065. Accordingly, other pipes with an outside diameter of 200 mm, 250 or 315 mm (e.g. made from PVC or PE) can also have the EAR fitted.



2 The arrow (mark of the upper crowning point) must be pointing upwards.



3 Coat the outer surface of the EAR with a thin layer of lubricant.



4 In the subsequent pipe connection process, ensure that the pipe pre-fitted with the EAR is inserted to the insertion depth mark according to the assembly instructions for AWADUCT FLEX-CONNECT (chapter 1.1) and the mark on the upper crowning point is still pointing upwards.

Observing the above points, carry out the assembly work according to chapter 1.1.

3 COMPENSATING RING

In case of large outside diameter differences of the sewer pipes, compensating rings can be used.

A maximum of 3 compensating rings can be fitted on top of one another. The compensating ring is clamped over the pipe and increases the outside diameter by approx. 22 mm per ring.



Mat.no.	Pipe outside diameter mm
14098101001	300 – 324
14177151001	325 – 349
14098111001	350 – 374
14177171001	375 – 399
14098121001	400 – 423*
14177191001	424 – 449
14098141001	450 – 499
14098151001	500 – 548*
14098171001	549 – 599
14098181001	600 – 649

**on request*



OVERVIEW OF CONNECTION SYSTEMS

AWADOCK

INSTALLATION INSTRUCTIONS AWADOCK DN160/200

For connection to AWASHAFT



1 Place the hole saw (refer to the Product book), where you want to connect the internal drop, on the side of AWASHAFT aligned with the centre of the shaft.

Hole sizes:

DN160: 200mm \pm 1

DN200: 250mm \pm 1

2 Debur and Clean the cut section.

3 Insert the seal into the hole. Please note, the arrows on the seal should be aligned vertically.



4 Please note, the seal must be properly installed on the inner side of the wall so that it lays flat on the shaft inner wall.

5 The inside of the seal must be properly lubricated. Insert the installation wrench on the AWADOCK and lock it. Screw the AWADOCK into the seal using the tool till it reaches the last thread.

6 In order to connect the pipe, the spigot end of the pipe shall be lubricated and then pushed home.

REHAU Pty Ltd

National Customer Service Centre Tel: 1300 768 033

Fax: 1300 760 665

Email: sales.au@rehau.com

www.rehau.com.au

Sydney

Suite 1.02, Level 1, Quad 1,
8 Parkview Drive,
Sydney Olympic Park NSW 2127
Direct Dial: 02 8741 4500

Adelaide

REHAU Pty Ltd
113 Anzac Highway, Ashford
SA 5035

Melbourne

REHAU Pty Ltd
9-11 Endeavour Way, Braeside
VIC 3195
Direct Dial: 03 9586 3100

Perth

REHAU Pty Ltd
G11, 59 Albany Highway
Victoria Park
WA 6100
Direct Dial: 08 9355 5700

QLD

REHAU Pty Ltd
PO Box 8148, Woolloongabba
QLD 4102



For the latest installation instruction, technical information, design service and training/installation videos visit www.myREHAU.com