



Engineering progress
Enhancing lives

Plumbing system RAUTITAN

Technical Information



This Technical Information "Plumbing system RAUTITAN" is valid from [Month YYYY](#).

Its publication means that the previous Technical Information 893621 (as of [Month YYYY](#)) is no longer valid.

Our current technical documentation can be found at www.rehau.com for download.

The documentation is protected by copyright. The rights justified by this, especially those of translation, reproduction, the drawing of illustrations, broadcasting, and rendering on photomechanical or by similar means as well as the storage in data processing systems, are reserved.

All measures and weights are approximate values. Errors and changes excepted.

Contents

Universal system RAUTITAN Introduction	5
Plumbing system RAUTITAN – Applications	
RAUTITAN universal system for drinking water	17
RAUTITAN universal system for heating	51
Gas system RAUTITAN gas	109
Insulation and noise protection	123
Fire protection	135
Plumbing system RAUTITAN – System guidelines, planning and assembly	
System guidelines, planning and assembly	139
Important instructions for connecting the pipes RAUTITAN stabil, the compression sleeves RAUTITAN PX stabil and fittings RAUTITAN RX+ stabil as RAUTITAN SX stabil in the sizes 50 and 63	142
Transport and storage	144
Pipes	145
Fittings and compression sleeves	151
Fittings and compression sleeves	155
System tools RAUTOOL	169
Expanding tools	174
Making the compression sleeve joint	177
Detaching the compression sleeve joint	184
Detaching the compression sleeve joint	185
Bending the pipes	187
Pipe support channel	190
Pipe fastening	192
Thermal length changes	194
Deflection legs	195
Fundamental regulations on laying pipes	199
Advices about system components until 2019	203
Advices about system components until 2013	205
REHAU sales offices	218



Universal system RAUTITAN Introduction

Contents

01	Information and safety advice	7
02	System components overview	11
03	System components overview	12
04	System components overview	13
05	System description	14
05.01	RAUTITAN pipes	14
05.02	REHAU compression sleeve jointing technique	15
05.03	Other system components	16

01 Information and safety advice

Validity

This Technical Information is only valid for **COUNTRY**.

Further applicable Technical Informations

- REHAU sanitary boxes
- Underfloor Heating and Cooling
- Industrial pipe system RAUPEX
- Pre-insulated industrial pipe system RAUFRIGO

Navigation

Each section of this Technical Information is designed with a grey register on the right side and begins with a table of contents, including the hierarchical titles and the corresponding page numbers.

Definitions

- **Supply lines or piping**
consist of pipes and their joints (e.g. compression sleeves, fittings, threads, or similar). This applies to gas piping, drinking water and heating piping and all other pipes in this Technical Information.
- **Piping systems, installations, systems**, etc. consist of the pipes and the necessary components.
- **Connection components**
consist of fittings with the corresponding compression sleeves and pipes as well as seals and screw connections.

Illustration

Illustrations for individual subsystems are listed in the corresponding pipe, fitting and compression sleeve colours.

Illustrations, which apply system-wide for drinking water, heating, and gas installation are illustrated with grey piping and white fittings/compression sleeves.

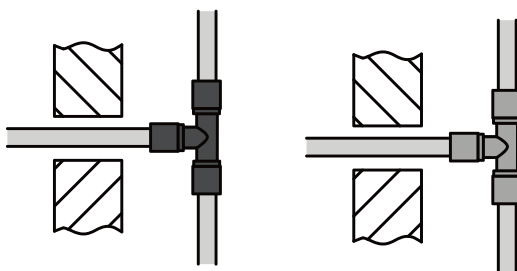





Sub-system illustration with RAUTITAN PX fitting

System-wide illustration

Fig. 01-1 Example: Illustration for sub-systems with RAUTITAN PX fittings (left) and example: System-wide illustration for multiple sub-systems (right)

Explanation of symbols

-  Safety information
-  Legal information
-  Important information, which needs to be taken into account
-  Your benefits/advantages
-  Information on the Internet

Updated Technical Information

For your own safety and the correct use of our products, check regularly whether the Technical Information which you have is available in a latest version. The date of issue of your Technical Information is always printed on the bottom left of the cover. The latest Technical Information can be found at your REHAU sales office, specialist wholesaler or online for download at www.rehau.com/TI

Piping network calculation

In addition to the information contained in this technical document various services are offered for the sizing of drinking water and heating systems by REHAU.

For extensive advice, please consult your REHAU sales office.

Intended use

The RAUTITAN system must only be planned, installed and operated as described in this Technical Information. Any other use that does not fall within the intended use of the system is prohibited.

Allowed connection components

- Please refer to the current price list for the exact assignment and the dedicated application of the connecting components.
- Connection components and processing tools that are not included in the current price list must be checked for compatibility and possible use before processing.

For detailed information, please contact your REHAU sales office.

Safety advice and operating instructions

- For your own safety and other's, read the safety instructions and the operating instructions carefully and completely before beginning installation.
- Store the operating instructions in a safe place and make sure it is available when needed..
- In case you did not understand the safety advice or the individual assembly situations, or if they are not clear to you, please contact your REHAU sales office.
- Failure to observe the safety information/instructions can result in damage to property and persons.

Observe the applicable national and international regulation on installation, accident prevention and safety when installing piping systems, as well as the instructions in this Technical Information.

Also observe the applicable laws, standards, guidelines and regulations (e.g. DIN, EN, ISO, DVGW, NEN, VDE and VDI) as well as regulations on environmental protection, provisions of professional associations and regulations of the local public utility companies.

Areas of application not contained in this Technical Information (special applications) require consultation with our Applications Department.

For detailed advice, please contact your REHAU sales office.

The design and installation instructions related solely to the specific REHAU product. Occasionally, references are made to parts of applicable standards and directives.

Always observe the current version of any guidelines, standards or directives. Further directives, regulations and guidelines related to the design, installation and operation of drinking water, heating and buildings services systems must also be referred but these do not form part of this Technical Information.

Staff requirements

- The system shall only be installed by authorised and trained persons.
- The work on electrical systems shall only be carried out by suitably trained and authorised people.

General safety precautions

- Keep your workplace clean and free of obstructions.
- Ensure adequate lighting at your workplace.
- Keep children, household pets and unauthorised people away from tools and the installation places. This applies particularly to refurbishment in occupied places.
- Only use those components in the corresponding piping system, which have been generally approved by REHAU. Using components which are not part of the system or tools which do not originate from the respective REHAU installation system can lead to accidents or other hazards.

Work clothing

- Wear eye protection, adequate work clothing, protective shoes, a helmet and a hair net if you have long hair.
- Do not wear loose clothing or jewellery which can be caught by moving parts.
- A safety helmet has to worn during installations work at face level or overhead.

Follow the assembly instructions

- Always read and observe the available operating instructions of the REHAU system tool.
- Incorrect handling of tools can cause cuts and crushing or sever limbs.
- Incorrect handling of tools can damage connection components and bring about leaks.
- The REHAU pipe cutters have sharp blades. Store and handle them in such a way that they will not create any risk of injury.
- When cutting the pipes, keep a safety distance between the holding hand and the cutting tool.
- When cutting do not reach into the cutting zone of the tool or near its moving parts.
- After the expansion process, the expanded end of the pipe returns to its original shape (memory effect). During this time, do not put any other objects into the expanded end of the pipe.
- Keep your hands away from movable parts or the tools pressing area during jointing.
- Before the joint is completed, the fitting may fall out of the pipe. Risk of injury!
- Always disconnect the power from a tool prior to carrying out maintenance work, changing over any moveable parts (e.g. compression jaws) or when moving the tool to a new location on site.

Operating parameter

If the operating parameters are exceeded, the pipes and joints may become overstressed. Not adhering to the operating parameters is thus not allowable. Keeping within the operating parameters must be ensured by safety/control equipments (e.g. pressure reducers, safety valves, etc.).

Fire protection

Pay carefully attention to the applicable fire protection regulations and the correspondingly valid building regulations/regional building regulations/ building codes, especially when:

- boring through ceilings and walls
- working in rooms with particular/tight requirements of preventative fire protection measures (observe national regulations)

Disposal

Separate product and packaging into the respective material groups (e.g. paper, metals, plastics or non-ferrous metals) and dispose them of in accordance to the national legislation.

Gas pipes: General safety measures

- Failure to observe the safety information/instructions may cause explosions and fire and can result in fatal damage to persons.
- Always observe the requirements of the NEN 1078.
- When planning and installing the gas installations, please proceed with extra care.
- Ensure through appropriate safety measures, that there is no possibility of uncontrolled gas leaks.
- Installation, modification and maintenance work on gas systems may only be carried out by the following persons:
 - gas utility person
 - the contracted installation company (which is listed in the installers index of the responsible operator)
- Consult your gas operator before starting laying the pipes.
- When working on gas systems, escape routes must be kept free at all times to ensure a quick and safe escape. Emergency exits are to be kept clear.
- According to NEN 1078 gas installations have to be verified through periodic maintenance measurements.

Gas piping: What to do if there is a smell of gas in buildings

- Open all doors and windows to create a breeze path, avoid rooms which smell of gas.
- Avoid any sparks or open flames / fires – if one is present extinguish it, do not smoke and do not use any lighters.
- Do not operate any electrical switches, plugs, door bells, phones and other communication devices in the building.
- Close the main lead and the isolating valve at the gas meter that lead into the building (Main shut-off device, „Fireplug“).
- Warn other occupants of the building, but do not use the door bells, and leave the building.
- Contact the service centre of the gas provider/utility from a phone outside the building.
- If you can hear leaking gas, leave the building immediately. Prevent anyone else from entering the building. Call the police and fire brigade from outside of the building!
- If the gas smell originates from a non-accessible room, contact the police and fire brigade immediately from outside of the building!

Gas piping: What to do in case of fire







- Call the fire brigade.
- Do not extinguish burning gas as unburned gas can be explosive.
- Close isolating valve at gas meter and/or main that leads into the building if it can be done without any danger.

Gas piping: Additional information



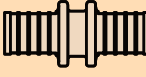
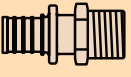
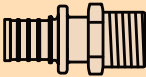
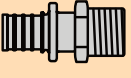

We recommend observing the following points, in addition to the safety requirements and accident prevention measures which are in force in your area:

- Do not smoke during work on gas installations and remove any other potential ignition sources.
- Prior to starting the work, close the respective isolating valves and secure them against unauthorized opening, e.g. by removing the handle or key.
- Ensure all inlets and outlets of gas pipes are closed and gas-tight, e.g. using end stops or plugs, if there is a possibility the isolating valve could be opened unauthorized, intentionally or accidentally or if you have to leave the workplace only for a short time.
- Ensure that all isolating valves are actually closed in a gas-tight manner.
- Once the pipe section you work on has been isolated correctly, the gas inside the pipe has to be vented out. The venting out of the gas has to be done in a safe manner using hoses.
- Pipe sections that are out-of-order or no longer in use or disconnected must be sealed permanently at their inlets and outlets in a gas-tight manner, e.g. by using plugs stoppers, end caps or blank flanges.
- Immediately seal all openings resulting from the dismantling of gas meters.
- Prior to cleaning the gas consumer piping, remove all gas appliances, pressure regulators, gas meters and fixtures. Clean the pipes by blowing out the pipes strictly to the outside of the building!
- If possible use gas detection devices for locating gas leaks. Never, under any circumstances, use a naked flame to search for a gas leak.
- In case of using foaming chemicals to locate leaks, be aware that hemp used for sealing joints can temporarily swell and prevent leakage detection.
- Upon completing the pipework installation, always carry out a test for gas leaks. For this test, the gas pipes must not be covered by anything. All joints must be free from any coats and the gas pipes must not be connected to any pipes carrying gas.
- Prior to putting the pipework back into operation, fill the pipes with the intended operating gas and purge out the air inside the pipes until all the air inside the pipes has been fully replaced by the gas. The exiting air/gas mix has to be safely discharged to the outside of the building.
- Prior to putting the complete gas installation into operation, make sure a pressure test is carried out successfully in accordance with rules and regulations currently in force and a pressure test protocol is completed.
- When putting a gas system into operation and the system is charged with gas, ensure all pipe openings are gas-tight.



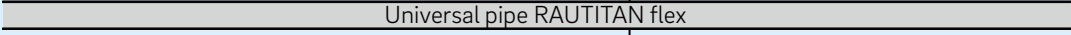



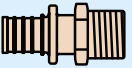
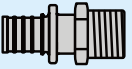
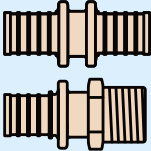





02 System components overview

Plumbing system RAUTITAN		
	Size 16–40	Size 50–63
RAUTITAN universal system for drinking water and heating		
Pipe	 Universal pipe RAUTITAN stabil	
	 Universal pipe RAUTITAN flex	
Compression sleeve	 RAUTITAN PX PVDF	 RAUTITAN PX stabil PVDF
Fitting	 RAUTITAN PX PPSU	 RAUTITAN RX+ stabil Gunmetal
	 RAUTITAN RX+ Gunmetal	 RAUTITAN SX stabil Stainless steel
	 RAUTITAN SX Stainless steel	 RAUTITAN SX stabil Stainless steel

03 System components overview

Plumbing system RAUTITAN		
	Size 16–40	Size 50–63
RAUTITAN universal system for drinking water and heating		
Pipe	 Universal pipe RAUTITAN stabil  Universal pipe RAUTITAN flex	
Compression sleeve	 RAUTITAN PX PVDF	 RAUTITAN MX/LX Brass
Fitting	 RAUTITAN PX PPSU  RAUTITAN RX+ Gunmetal  RAUTITAN SX Stainless steel	 RAUTITAN RX+ Gunmetal

04 System components overview

Plumbing system RAUTITAN		
	Size 16–40	Size 50–63
RAUTITAN universal system for drinking water and heating		
Pipe	 Universal pipe RAUTITAN stabil	
	 Universal pipe RAUTITAN flex	
Compression sleeve	 RAUTITAN PX PVDF	 RAUTITAN PX stabil PVDF
Fitting	 RAUTITAN PX PPSU  RAUTITAN LX +G Standard brass  RAUTITAN LX / RAUTITAN RX+ Standard brass / Gunmetal  RAUTITAN SX Stainless steel	 RAUTITAN RX+ stabil Gunmetal  RAUTITAN SX stabil Stainless steel
Gas system RAUTITAN gas		
	Size 16–40	Size 50–63
Pipe	 Gas pipe RAUTITAN gas stabil	
Compression sleeve and fitting	 RAUTITAN PX PVDF  RAUTITAN LX +G Standard brass	

05 System description

05.01 RAUTITAN pipes



Fig. 05-1 RAUTITAN pipes



- Corrosion resistance of the RAUTITAN pipes:
No pitting
- Acoustic insulation properties of the RAU-PE-Xa pipe material
- No tendency to deposits or encrustation
- High impact toughness of the RAU-PE-Xa pipe material
- Good resistance to abrasion
- Optional pre-insulation in the factory in various shapes and insulation thicknesses
- Optional protective sleeving in the factory
- Application-oriented delivery packaging of the pipes as coils or cut lengths

stabil

Universal pipe RAUTITAN stabil

- Universally suitable for drinking water and heating installation
- Aluminium layer to prevent oxygen diffusion
- Sizes 16–63
- Rigid and resistant to deformation

flex

Universal pipe RAUTITAN flex

- Universally suitable for drinking water and heating installation
- Oxygen diffusion-tight according to DIN 4726
- Sizes 16–40
- Flexible

gas stabil

Gas pipe RAUTITAN gas stabil

- Suitable for the gas installation
- Aluminium layer to prevent oxygen diffusion
- Sizes 16–40
- Rigid and resistant to deformation

05.03 Other system components



Fig. 05-4 Insulating box for RAUTITAN elbow with passage



Fig. 05-5 RAUTOOL tools



Fig. 05-6 Bracket range



Fig. 05-7 Pipe bend bracket



Fig. 05-8 RAUTOOL tools



Fig. 05-9 Pipe support channel



RAUTITAN universal system for drinking water

Contents

06	Area of application	19
06.01	RAUTITAN connection components for drinking water installation	19
07	Area of application	20
07.01	RAUTITAN connection components for drinking water installation	20
08	Area of application	21
08.01	RAUTITAN connection components for drinking water installation	21
08.02	Standards and guidelines	22
08.03	Requirements of the drinking water	23
08.04	Standards and guidelines	24
08.05	Requirements of the drinking water	24
08.06	Limitation of use RAUTITAN LX	25
09	Drinking water hygiene	26
09.01	Materials in contact with drinking water	26
09.02	Pipe network calculation	27
09.03	Operating temperatures	27
09.04	Pipe layout	28
09.05	Water contamination - Basic rules for a disinfection	32
10	Assembly components	34
10.01	Flush-mounted and exposed installation	34
10.02	Surface mounting	35
11	Connection of piping to the water heaters	36
11.01	Electrical instantaneous water heaters	36
11.02	Gas instantaneous water heaters	36
11.03	Hot water tanks	36
11.04	Solar thermal systems	36
12	Pressure test and purging	37
12.01	Guidelines for pressure test	37
12.02	Leak test of drinking water installations with water	37
12.03	Pressure test with oil free pressurised air or inert gas	39
12.04	Purging drinking water pipes	40
12.05	Pressure test record: REHAUS's RAUTITAN system (drinking water installation)	40
13	Resistance coefficients and Pressure loss tables	43
13.01	Resistance coefficients (zeta values ζ) of the REHAU RAUTITAN fittings according to DVGW W 575 (extract)	43
14	Resistance coefficients and Pressure loss tables	45
14.01	Resistance coefficients (zeta values ζ) of the REHAU RAUTITAN fittings according to DVGW W 575 (extract)	45
14.02	Pressure loss table: Drinking water installation RAUTITAN stabil 16–40	47
14.03	Pressure loss table: Drinking water installation RAUTITAN stabil 50–63	48
14.04	Pressure loss table: Drinking water installation RAUTITAN flex 16–25	49
14.05	Pressure loss table: Drinking water installation RAUTITAN flex 32–40	50







06 Area of application

06.01 RAUTITAN connection components for drinking water installation

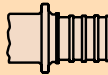
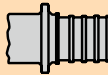

Fig. 06-1 RAUTITAN pipes for drinking water installation

RAUTITAN connection components for drinking water installation

Size	Pipes	Fittings	Compression sleeves
16	<div style="border: 1px solid black; width: 100px; height: 10px; margin-bottom: 5px; text-align: center;">flex</div> Universal pipe RAUTITAN flex	 RAUTITAN PX	 RAUTITAN PX
20		 RAUTITAN RX+	
25		 RAUTITAN SX	
32		<div style="border: 1px solid black; width: 100px; height: 10px; margin-bottom: 5px; text-align: center;">stabil</div> Universal pipe RAUTITAN stabil	
40	<div style="text-align: center;">-</div>	 RAUTITAN RX+ stabil	 RAUTITAN PX stabil
50		 RAUTITAN SX stabil	
63			





07 Area of application

07.01 RAUTITAN connection components for drinking water installation

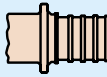
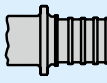

Fig. 07-1 RAUTITAN pipes for drinking water installation

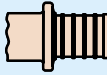
RAUTITAN connection components for drinking water installation

Size	Pipes	Fittings	Compression sleeves	
16	<div style="text-align: center;"> stabil Universal pipe RAUTITAN stabil </div>	<div style="text-align: center;"> flex Universal pipe RAUTITAN flex </div>	<div style="text-align: center;">  RAUTITAN PX  RAUTITAN RX+  RAUTITAN SX </div>	<div style="text-align: center;">  RAUTITAN PX </div>
20				
25				
32				
40	<div style="text-align: center;"> - </div>	<div style="text-align: center;">  RAUTITAN RX+ </div>	<div style="text-align: center;">  RAUTITAN MX </div>	
50				
63				









08 Area of application

08.01 RAUTITAN connection components for drinking water installation

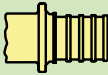

Fig. 08-1 RAUTITAN pipes for drinking water installation

RAUTITAN connection components for drinking water installation

Size	Pipes	Fittings	Compression sleeves
16		 RAUTITAN PX	
20		 RAUTITAN LX +G	
25	<hr style="width: 50px; margin: 0 auto;"/> flex Universal pipe RAUTITAN flex	 RAUTITAN LX RAUTITAN RX+	 RAUTITAN PX
32	<hr style="width: 50px; margin: 0 auto;"/> stabil Universal pipe RAUTITAN stabil	 RAUTITAN SX	
40			
50		 RAUTITAN RX+ stabil	
63		 RAUTITAN SX stabil	 RAUTITAN PX stabil

08.02 Standards and guidelines

§

The RAUTITAN universal system for drinking water and heating must be designed, installed and operated according to DIN EN 806, DIN EN 1717 and the national amendments DIN 1988 and the acknowledged technical rules.

Operating parameters

Application:

Hot water supply at 70 °C / 1 MPa (10 bar)

(Application class 1-2 acc. ISO 10508)

Design temperature T_D	/ Time t_D	70 °C / 49 years
Short-term maximal temperature T_{max}	/ Time t_{max}	80 °C / 1 year
Short-term malfunction temperature T_{mal}	/ Time t_{mal}	95 °C / 100 h
Total		50 years

Tab. 08-1 Operating parameters according to DIN EN 806-2, DIN 1988-200 and ISO 10508 (Application classes 1 and 2)

The following legislation, standards and guidelines are met:

DVGW

- DVGW registration for pipes and jointing techniques (all sizes).
- Permanently leak proof compression sleeve jointing technique according to DIN EN 806, DIN 1988 and DVGW-worksheet W 534 with DVGW registration.
- Suitable for applications with special hygiene requirements according to DVGW worksheet W270 (Reproduction of micro-organisms on materials for the drinking water area).

DIN standards, legislation, guidelines

- Universal pipes RAUTITAN stabil and RAUTITAN flex as well as RAUTITAN PX fittings follow to the Evaluation criteria for plastics and other organic materials in contact with drinking water.
- RAUTITAN fittings, which are in contact with drinking water, are made of PPSU. The compression sleeve metal fittings for drinking water applications provided by REHAU comply with the list of the German Federal Environmental Agency „Empfehlung des Umweltbundesamtes – Trinkwasserhygienisch geeignete metallene Werkstoffe“.

08.03 Requirements of the drinking water

The drinking water must comply with the currently valid limits of the following standards:

- DIN 2000
- German drinking water regulation¹⁾
- Council directive 98/83/EC of 3 November 1998 on the quality of water intended for human consumption



The fittings RAUTITAN RX+ are made of gunmetal and therefore especially corrosion resistant.

Nonetheless, there is no universal material which can be used for every application. Thus, different factors can influence the corrosion in the drinking water installation, regardless of the material used.

With the fitting RAUTITAN MX, that was sold until 2013, corrosion can occur in some specific cases even though the water quality is within the permitted range of the drinking water regulation. The chloride concentration and the hydrogen carbonate concentration of the water have considerable influence on how aggressive the corrosion of brass is. High chloride concentrations combined with low hydrogen carbonate concentrations can negatively influence the corrosion behaviour. In such water supply regions we recommend the use of the stainless steel fittings RAUTITAN SX or RAUTITAN RX+ of gunmetal.

However, the interaction under the following factors, according to DIN EN 12502-1:2005 (D), also influence the corrosion resistance:

- Material properties (chemical composition, surface integrity)
- Water quality (physical and chemical properties, solid matter)
- Planning and execution (geometry, mix installation, connections)
- Leak test and initial start-up (purging, drainage, disinfection)
- Operating conditions (temperature, temperature changes, flow conditions)

¹⁾ The limit values for maximum disinfection agent concentrations detailed in the drinking water regulation are not to be interpreted as permanent, lasting application concentrations. They represent the temporary maximum values defined under hygienic and toxicological aspects. Top priority of the drinking water regulation is the principle of minimisation, that is, nothing should be mixed into the water. Only if a chemical additive is required due to contamination may the minimum amount required be mixed in.



The application of water after-treatment, like, for example, water softening, in principle, changes the corrosive-chemical behaviour of the water. To avoid corrosion damage due to an incorrect use and operation of a water treatment system, we explicitly recommend that you have your individual situation examined beforehand by an expert or, for example, by the system manufacturer.

Furthermore, practical experiences with the water which is to be distributed in the area of use should be drawn upon when it comes to evaluating the likelihood of corrosion.

It is the responsibility of the system design that the above-mentioned factors and parameters be taken into account when it comes to corrosion protection and stone formation in actual application.

If the drinking water quality is outside the limits of the drinking water regulation, evaluation and approval is definitely required if the RAUTITAN system is intended to be used.

In this case, please contact your REHAU sales office.

08.04 Standards and guidelines

The RAUTITAN universal system for drinking water and heating must be designed, installed and operated according to DIN EN 806, DIN EN 1717 and the national amendments DIN 1988 and the acknowledged technical rules.

Operating parameters

Application:

Hot water supply at 70 °C / 1 MPa (10 bar)
(Application class 1-2 acc. ISO 10508)

Design temperature T_D	/ Time t_D	70 °C / 49 years
Short-term maximal temperature T_{max}	/ Time t_{max}	80 °C / 1 year
Short-term malfunction temperature T_{mal}	/ Time t_{mal}	95 °C / 100 h
Total		50 years

Tab. 08-2 Operating parameters according to DIN EN 806-2, DIN 1988-200 and ISO 10508 (Application classes 1 and 2)

The following legislation, standards and guidelines are met:

DVGW

- DVGW registration for pipes and jointing techniques (all sizes).
- Permanently leak proof compression sleeve jointing technique according to DIN EN 806, DIN 1988 and DVGW-worksheet W 534 with DVGW registration.
- Suitable for applications with special hygiene requirements according to DVGW worksheet W270 (Reproduction of micro-organisms on materials for the drinking water area).

DIN standards, legislation, guidelines

- Universal pipes RAUTITAN stabil and RAUTITAN flex as well as RAUTITAN PX fittings follow to the Evaluation criteria for plastics and other organic materials in contact with drinking water.
- RAUTITAN fittings, which are in contact with drinking water, are made of PPSU, standard brass according to DIN EN 1254-3, gunmetal or stainless steel.

The compression sleeve fittings for drinking water applications provided by REHAU comply with the list of the German Federal Environmental Agency „Empfehlung des Umweltbundesamtes - Trinkwasserhygienisch geeignete metallene Werkstoffe“.

08.05 Requirements of the drinking water

The drinking water must comply with the currently valid limits of the following standards:

- DIN 2000
- German drinking water regulation¹⁾
- Council directive 98/83/EC of 3 November 1998 on the quality of water intended for human consumption



With its RAUTITAN LX fittings made of standard brass, REHAU meets the requirements according to DIN EN 1254-3. Nonetheless, there is no universal material which can be used for every application. Water quality which can cause corrosion and special interaction within an drinking water installation (according to DIN EN 12502-1) can damage brassfittings.

1) The limit values for maximum disinfection agent concentrations detailed in the drinking water regulation are not to be interpreted as permanent, lasting application concentrations. They represent the temporary maximum values defined under hygienic and toxicological aspects. Top priority of the drinking water regulation is the principle of minimisation, that is, nothing should be mixed into the water. Only if a chemical additive is required due to contamination may the minimum amount required be mixed in.

08.06 Limitation of use RAUTITAN LX

The ratio of chloride and hydrogen carbonate contents can negatively influence the water's corrosiveness and lead to the selective form of corrosion, dezincification, in RAUTITAN LX fittings. To avoid the corrosion of the fittings RAUTITAN LX, following maximal concentration shall not be exceeded:

- Chloride content (Cl_-) ≤ 200 mg/l
- Sulphate content (SO_4^{2-}) ≤ 250 mg/l
- Calculated calcite solubility capacity ≤ 5 mg/l (achieved as soon as pH value ≥ 7.7)

Furthermore to evaluate whether or not unfavourable conditions exist in relation to this, the following Turner diagram should be used (see Fig. 08-2).

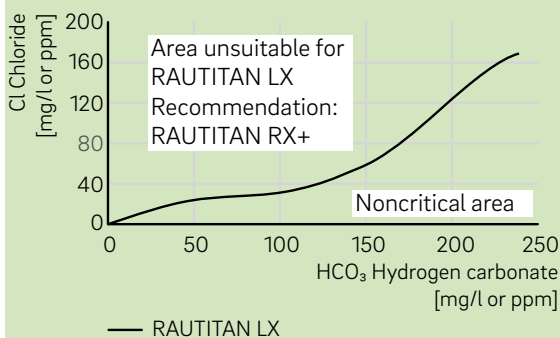

Fig. 08-2 Turner diagram
(Source Wieland Werke Germany)

For water qualities which are above the limit curve for RAUTITAN LX, dezincification will need to be assumed. In this case, RAUTITAN LX fittings may no longer be put to use. The usability of alternative fitting materials is to be examined.

In such water supplying regions we recommend the use of the fittings RAUTITAN SX of stainless steel or RAUTITAN RX+ of gunmetal.



The application of water after-treatment, like, for example, water softening, in principle, changes the corrosive-chemical behaviour of the water. To avoid corrosion damage due to an incorrect use and operation of a water treatment system, we explicitly recommend that you have your individual situation examined beforehand by an expert or, for example, by the system manufacturer.

Furthermore, practical experiences with the water which is to be distributed in the area of use should be drawn upon when it comes to evaluating the likelihood of corrosion.

It is the responsibility of the system design that the above-mentioned factors and parameters be taken into account when it comes to corrosion protection and stone formation in actual application.

If the drinking water quality is outside the limits of the drinking water regulation, evaluation and approval is definitely required if the RAUTITAN system is intended to be used.

In this case, please contact your REHAU sales office.

09 Drinking water hygiene

In order to comply with the requirements of the German Drinking Water Ordinance and to avoid contamination in drinking water installations, various standards, guidelines and the generally recognized rules of technology (e.g. DIN 1988, DIN EN 806, DVGW W 551, etc.) have to be taken into account.



Different factors affect the drinking water installation hygiene. These factors, some basic rules and important advices for the correct design, execution and working of a drinking water installation will be explained / described in the following chapter.



It is always necessary that all those involved in the drinking water installation (e.g. specialist planners, specialist tradesmen, owners and users) deal with each individual drinking water installation in detail and act together in such a way that optimum drinking water hygiene can be achieved and ensured.

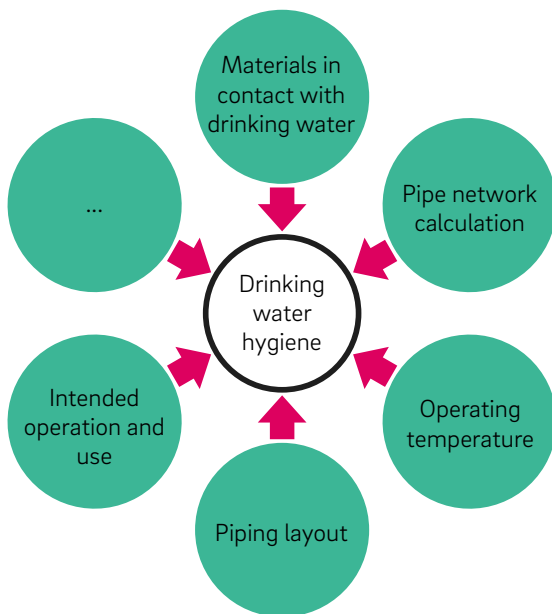

Fig. 09-1 Some important factors influencing drinking water hygiene



For detailed and individual advice, please contact your REHAU sales office.

09.01 Materials in contact with drinking water

The proven hygienic properties of the installation installation system are the most important basis for safe drinking water distribution in the building.

In concrete terms, this means:

- Use only systems and components approved for drinking water applications. Required verifications can be found in the respective system approvals, e.g. DVGW certificates or similar.
- Use metallic materials that are included in the list of the Federal Environment Agency „Assessment basis for metallic materials in contact with drinking water“.
- Use plastics, sealing materials and auxiliary materials that do not have a negative impact on drinking water and have been proven not to promote the proliferation of microorganisms. (DVGW W 270, Evaluation principles for plastics and other organic materials in contact with drinking water).

These requirements are part of the system approval according to DVGW specifications and are fulfilled by all RAUTITAN components.



The o-ring free RAUTITAN compression sleeve jointing system, which is considered as cavity free, furthers the drinking water hygiene.

09.02 Pipe network calculation

The water exchange is mainly influenced by the use of the drinking water system (intended operation). The factors for sufficient flow during intended operation must be taken into account especially during the planning phase (pipe network calculation according to DIN 1988-300) and during professional execution.

According to DIN 1988-200, all individual supply lines should be as short as possible, and at the same time the minimum principle applies (keep volume as low as possible).

An important parameter is the so-called 3 liter rule (upper limit of the pipe volume for cold and hot drinking water pipes).

Diameter	Universal pipe RAUTITAN stabil	Universal pipe RAUTITAN flex
	stabil	flex
16	ca. 31 m	ca. 28 m
20	ca. 19 m	ca. 18 m
25	ca. 12 m	ca. 12 m
32	ca. 7 m	ca. 7 m
40	ca. 5 m	ca. 4 m

Tab. 09-1 Length of RAUTITAN pipes with a water content of 3 l

09.03 Operating temperatures

Particular attention must be paid to the temperatures to be expected during operation. The principles apply that cold-going lines must be protected against heating and hot-going lines against impermissible cooling.

Critical temperature ranges between 25 - 55 °C, e.g. in the case of cooling or heating due to stagnation, are to be avoided or reduced to a minimum.

Avoid circulation lines on the floor as far as possible (observe measures for line volumes greater than 3 liters) to prevent additional permanent heat input into the building structure (e.g. into the pre-wall installation or other components).



Avoid constant flow through direct connections of concealed and surface-mounted mixing valves, especially in hot water lines, in order to prevent inadmissible heat transfer to other connections, e.g. cold water, mixed water, etc.

If this is not possible, the pipe through which the flow passes must be connected as an individual connection pipe with a sufficient distance (see Fig. 09-2) to the tapping point (thermal separation/consideration of thermosiphon effect). Therefore, the use of a double wall elbow or other direct connection is not permitted for this type of connection.

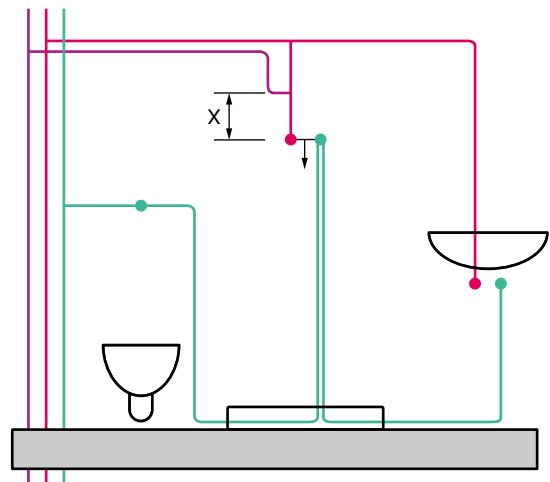

X Recommended values see table below

Fig. 09-2 Connection of mixer taps to pipe permanently provided with warm water - Example: Connection from top

Recommended values X¹⁾

Connection from top	≥ 15 cm
Lateral connection	≥ 30 cm
Connection from bottom-up	≥ 45 cm

1) Recommended values based on REHAU inhouse measurements

09.04 Pipe layout

The piping layout, especially on the floor, can influence the drinking water quality. Here, particular attention must be paid to the intended operation (sufficient flow), sufficient insulation of the piping and a piping calculation in line with requirements.

The following are possible installation types with notes:

Optimale Durchströmung der Trinkwasserleitung

Mögliche Rohrleitungs-führung auf dem Stockwerk	T-piece-Installation	Series installation	Ring installation	Manifold installation
Selection criteria	<ul style="list-style-type: none"> Regular and frequent use of each draw-off point 	<ul style="list-style-type: none"> Regular and frequent use of the last draw-off point 	<ul style="list-style-type: none"> Regular and frequent use of any draw-off point within the ring 	<ul style="list-style-type: none"> Regular and frequent use of each draw-off point
Useful information	<ul style="list-style-type: none"> Design branch and main branch pipes as short and small as possible. Place draw-off points with an increased water consumption (such as e.g. "wellness shower") close to the riser. Connect regularly used draw-off points (such as e.g. toilet with a flushing cistern) at the end of the storey pipe distribution. 	<ul style="list-style-type: none"> The allowed upper pipe volume of 3 l limits the available pipe length and is often critical in series installations (see Tab. 09-1). Place draw-off points with an increased consumption close to the riser (such as e.g. "wellness shower"). Connect regularly used draw-off point (such as e.g. toilet with a flushing cistern) at the end of the storey distribution. Place the connection pipe of rarely or infrequently used draw-off point (such as e.g. bidet) within the series installation. 	<ul style="list-style-type: none"> Due to the long pipe runs of this kind of installation, the max. time of 30 s to reach the allowed water temperature at the draw-off point ($\geq 55\text{ °C}$ for hot water and $\leq 25\text{ °C}$ for cold water) has to be critically considered during the design. Flexible place of draw-off points in the ring is possible, as the entire ring is flushed during any drawing process. 	<ul style="list-style-type: none"> Design branch and main branch pipes as short and small as possible.

Tab. 09-2 General and useful information about the design and execution of small plants or storey pipes

09.04.01 Special application: Not regularly used draw-off points

Laying pipes as a ring installation is the commonly used solution to avoid stagnation in drinking water installation. As soon as water is tapped at an installation point the water in the ring is set in motion. Even so, stagnation can occur in this kind of installation if water is not or at least rarely tapped. For example in the connection pipe to exterior water tap in garden or to a filling unit for heating installation.

In small installations this can be avoided connecting the ring to the cold water riser in a special manner. This solution required only two T-pieces RAUTITAN PX or two bend t-pieces RAUTITAN RX+.



- Drinking water hygiene improvement when tapping points are not regularly used
- Used in combination with the wall mounted elbow with passage, enable the improvement of the water flow in ring installation
- Water change-out in the ring during water circulation in the riser without using moving parts
- Maintenance-free according to DIN EN 806-5 (no requirements concerning inspection)

09.04.01.01 Working principle

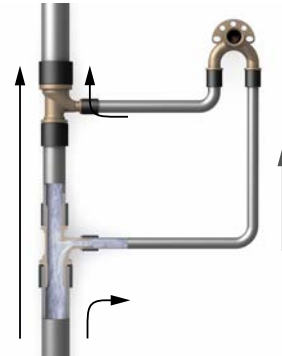

Fig. 09-3 Working principle of a ring installation with bend t-piece RAUTITAN RX+

At a defined minimal water flow in the riser the intermediate pipe with a specified length between two t-pieces causes a pressure loss which generates the water circulation in the ring.

Other possible connections of the ring pipe



Fig. 09-4 Possible connections of the ring pipe

The ring pipe is joined to the riser with T-pieces (RAUTITAN RX+, RAUTITAN PX). Depending on the max. calculated water flow the riser diameter can be reduced or not.

09.04.01.02 Example of „not regularly used tapping points“ in residential building

The solution from REHAU is particularly aimed for the water supply of not regularly used tapping points in cold water installations in small residential buildings.

In larger buildings, like e.g. sport facilities, hotels, hospitals or schools the water supply and circulation of cold and hot water have to be independent from the effective water consumption. For that, special tapping devices or automatic flushing devices have to be used. For detailed information about these solutions and their use please contact your sales office.

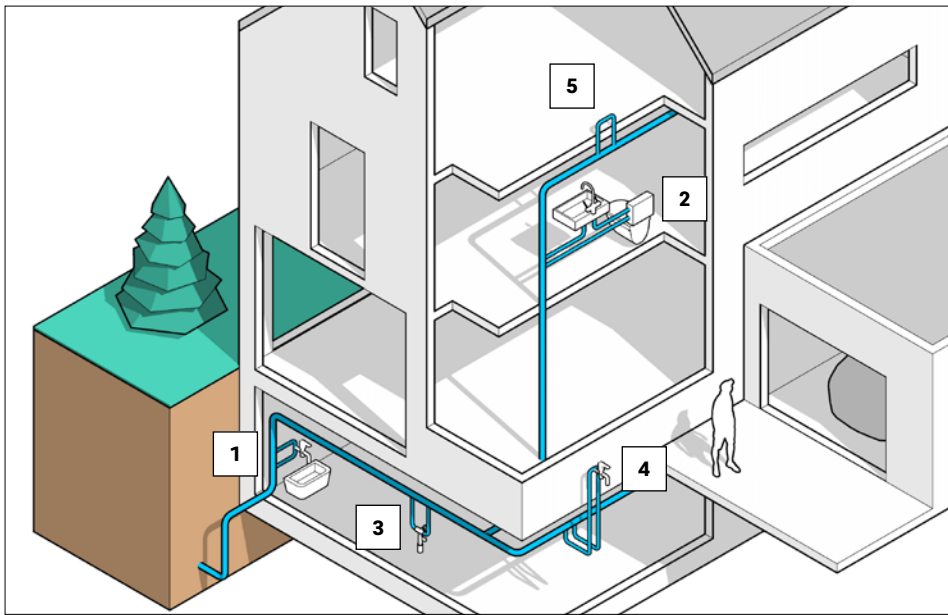

- 1 Utility room
- 2 Guest-WC
- 3 Filling unit for heating installation
- 4 Frost-free exterior water tap in garden
- 5 "Advanced" water installation

Fig. 09-5 „Not regularly used tapping points“ in residential building

09.04.01.03 „Not regularly used tapping points“: Application in detail

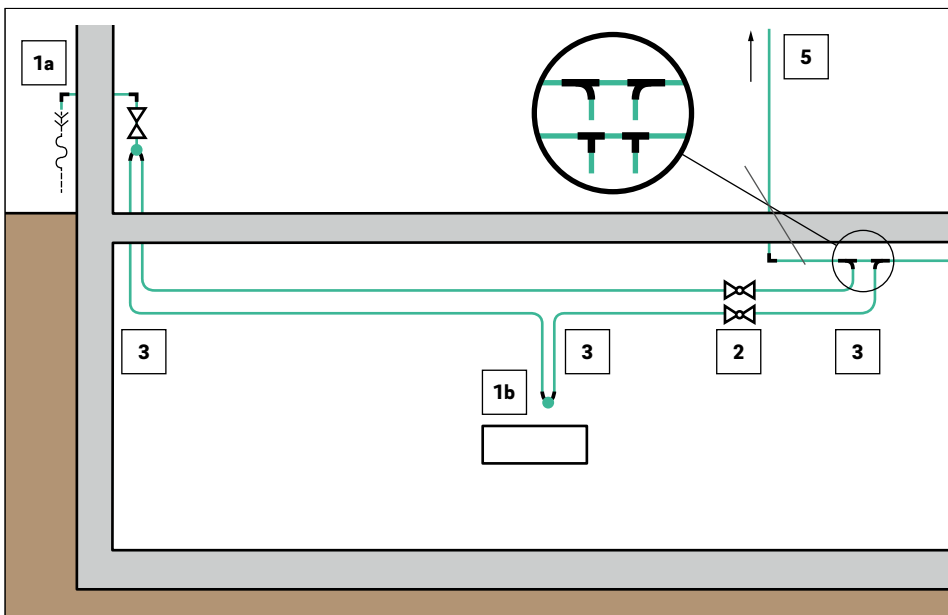

- 1 Not regularly used tapping point
- 1a Exterior water tap (frost resisting tap)
- 1b Sink
- 2 Low pressure loss tap (ball valve)
- 3 Pipe elbow
- 4 Bend-T-pieces in combination with a pipe piece with a smaller diameter
- 5 Distribution line (cold water)

Fig. 09-6 Laying of an exterior water tap and a sink in cellar

09.04.01.04 Application limitations and boundary conditions of use



- Application for max. 2 tapping points in the ring.
- Keep the pressure loss in the ring as low as possible.
- Only bend the pipe (without fitting).
- Use of low pressure loss tap (e.g. ball valve instead of valve).
- Available only for cold water application.
- Observe the max. ring pipe length. If necessary the size diameter of the ring has to be increased (considering the response time!) or the ring has to be split.

The sizing tables (see Chap „09.04.01.05 Design“) don't replace the sizing and design of the drinking water installation with a suitable design program like RAUCAD. They only attend to enable the correct choice and use of the system components considering the size of the ring and the riser.



The intended use of the riser including a sufficient flow rate has to be granted. Considering that, following design parameters have to be considered:
Flow rate in the riser > 1 m/s during at least 90 seconds per day

The volume flow rates given in Tab. 09-3 correspond to a flow rate of 1 m/s:

Riser size	Min. volume flow rate
20	0.16 l/s
25	0.25 l/s
32	0.42 l/s
40	0.66 l/s

Tab. 09-3 Riser size and min. volume flow rate

If necessary automatic flushing devices with programmable hygienic flushing or sanitary devices with a high and regular water consumption (like e.g. shower or WC-flush) have to be installed at the end of the riser.

09.04.01.05 Design

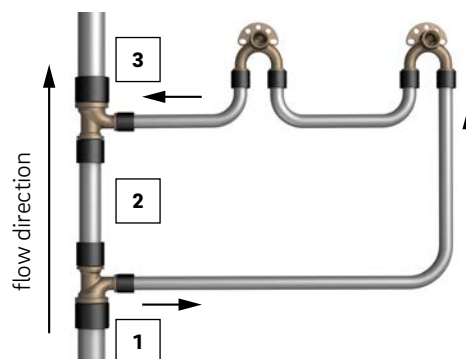

Fig. 09-7 working principle: pipe ring with bend-t-piece RAUTITAN RX+

- 1 Riser entry
- 2 Intermediate pipe
- 3 Riser outlet

Ring

The max. ring length shall not exceed following values:

Ring size	Max. length
16	15 m
20	20 m

Tab. 09-4 Max. ring length

Intermediate pipe and riser outlet

Following parameters apply:

Riser entry Size	Intermediate pipe Size	Length [mm]	Riser outlet Size
20	16	100	16 or 20
25	20	100	20 or 25
32	25	150	25 or 32
40	32	200	32 or 40

Tab. 09-5 Intermediate pipe and riser outlet

09.05 Water contamination - Basic rules for a disinfection

Due to an incorrect planning, construction and operation, through prolonged stagnation or substandard water quality (e.g. wastewater, floodwater, maintenance works on the piping network), contamination can occur. Furthermore, damage to the piping network, e.g. a supply line with external water inflow, can be the cause of possible contamination. The requirements of the work sheets DVGW W551 and DVGW W551-3 have to be considered while disinfecting a drinking water installation.

The disinfection of a drinking water installation is only necessary in exceptional cases (in the case of contamination) and all operational and structurally engineered system deficiencies are to be rectified first. Repeated or constant bacterial contamination of the water in a domestic installation is often caused by the method of installation (e.g. dead legs) or by the method of operation (e.g. long stagnation periods) and does not justify continuous disinfection.

09.05.01 Thermal disinfection in the case of contamination

For drinking water installations in compliance with the latest technical standards dirt can be removed by flushing thoroughly with water as long as the dirt is water-soluble or remains soluble in water.

If contamination is suspected, an additional thermal disinfection as per DVGW worksheet W 551 is both possible as an urgent measure and sensible. According to the latest technical standards, water temperatures of at least 70 °C are most likely to kill off germs and bacteria, including legionella, found freely in water. It is important that appropriate measures are taken to ensure people are not scalded.

All piping of the RAUTITAN universal system for drinking water and heating are suitable for repeated thermal disinfection according to the DVGW-worksheet W 551 at 70 °C. It must be ensured that the allowable operating pressure is not exceeded during thermal disinfection.

09.05.02 Chemical disinfection in case of contamination

Decontamination processes include alongside thermal disinfection also more and more chemical disinfection. Chemical and thermal disinfection measures always put the materials used in the drinking water installation under strain. It is industry wide accepted, that some disinfection methods are not suitable for materials commonly used in plumbing/heating installations. This also applies to materials, for which it was previously assumed that they were sufficiently corrosion-resistant, e.g. non-rusting steel, copper and some synthetic materials.

Before introducing these types of process measures, it needs to be ensured that all parts of the installation system are thermally and chemically suited for the corresponding measure. This is regulated by the DVGW worksheet W 551. If necessary, please have the suitability of the disinfectant approved by the disinfectant's manufacturer for all system parts of the installation.

09.05.02.01 Discontinuous chemical disinfection

For short-term chemical disinfections (discontinuous) only special agents may be used which are specified in corresponding rules and standards.

Carrying out the disinfection process according to the specifications of the DVGW worksheet W 551-3 can be done without affecting the functionality of a REHAU drinking water installation if the agents, concentrations, application durations and maximum temperatures, as listed in Tab. 09-6, are observed.

It should be noted that combined thermal-chemical disinfection at temperatures of higher than 25 °C, as well as permanent or regular disinfection cycles (e.g. monthly), are not permitted. In relation to the life span of the piping, the total number of disinfection cycles is limited to five discontinuous cycles. Otherwise, it cannot be guaranteed that the specified life-spans will be achieved.

The person carrying the disinfection out must guarantee that water is not used for human consumption (e.g. as drinking water) at any time during the disinfection phase, including the subsequent rinsing phase.

Description	Commercial size and packing	Storage	Safety advice ¹⁾	Max. application concentration ²⁾ application duration and temperature in the piping
Hydrogen peroxide H ₂ O ₂	Hydrous solution in various concentrations	Light-protected, cool, avoid contamination at all costs	With >5 % solutions, protective equipment necessary	150 mg/l H ₂ O ₂ Max. 24 h T _{max} ≤ 25 °C
Sodium hypochlorite NaOCl	Hydrous solution with maximum 150 g/l chlorine	Light-protected, cool, sealed and in a collecting reservoir	Alkaline, corrosive, toxic, protective equipment necessary	50 mg/l chlorine Max. 12 h T _{max} ≤ 25 °C
Chlorine dioxide ClO ₂	Two components (Sodium chloride, sodium peroxide sulphate)	Light-protected, cool and sealed	Oxidizing effect, do not inhale chlorine dioxide, protective equipment necessary	6 mg/l ClO ₂ Max. 12 h T _{max} ≤ 25 °C

1) The corresponding notes in the safety data sheets of the manufacturer must be considered.

2) REHAU approval; this value may not be exceeded at any stage during the entire application duration of the installation.

Tab. 09-6 Discontinuous disinfection, active agents and concentrations according to for example DVGW W551-3

09.05.02.02 Continuous chemical disinfection

We cannot recommend using continuous dosing systems for chemical disinfection in domestic installations, especially as a measure for legionella prevention, due to the possible material damages of installation components which may occur. We cannot provide any guarantees in such cases.

Sometimes it may be the case that chemical disinfection is necessary for a prolonged period of time, until any structural refurbishment work has been completed. These disinfection measures may only be carried out if a permitted method is used. The parameters listed in Tab. 09-7 must be monitored and documented for the full duration of the disinfection process, immediately after the dosing point. The parameters according to Tab. 09-7 can be applied to the system RAUTITAN for drinking water applications.

Description ¹⁾	Max. application concentration ²⁾	Max. application duration in the piping ³⁾	Application temperature in the piping
Chlorine Cl ₂	Max. 0.3 mg/l Free chlorine	4 months	60 °C
Chlorine dioxide ClO ₂	Max. 0.2 mg/l ClO ₂	4 months	60 °C

1) The corresponding notes in the safety data sheets of the manufacturer must be considered.

2) REHAU approval; this value may not be exceeded at any stage during the entire application duration of the installation.

3) Maximum application duration, accumulated over the entire system life span

Tab. 09-7 Prolonged chemical disinfection, active agent and concentration according to drinking water regulation

In relation to the life span of the pipe, the total disinfection time is limited to four months. In case of longer times the life span of the pipes can be reduced. We generally exclude disinfecting agents other than those listed for use with our pipes, particularly strong oxidizing agents (e.g. ozone).



Chemical and thermal disinfection procedures which are carried out incorrectly can permanently damage components in the drinking water installation.

Prior to commencing any such procedures, all parts of the installation must be checked if they are thermally and chemically suited to the selected method. In doubt please obtain the confirmation from the manufacturer of the disinfecting agent.

With thermal disinfection, it is important that the appropriate measures be taken to ensure that people are not scalded.

When carrying out discontinuous chemical disinfection it must be guaranteed that water is not removed for human consumption (e.g. as drinking water) at any time during the disinfection phase, including the subsequent flushing phase.

The safety advice of the disinfectant manufacturers must be observed.

10 Assembly components



Installing incorrect connection components can lead to damage or destruction of the connection components.

- Do not mix up the RAUTITAN connection components with the underfloor heating/cooling connection components (e.g. system transitions made of stainless steel).
- Please note the measurements on the connection components.
- Do not use any RAUTITAN system fittings, which are marked on the packaging as heating fittings, in the drinking water installation (e.g. radiator connection bends, radiator connection tees, cross fittings).
- You can find the precise assignment of the connection components in the current price list.

10.01 Flush-mounted and exposed installation



Fig. 10-1 Bracket range

Bracket range for RAUTITAN elbows and fitting connections

- With noise insulating plate
- Rugged and flexible execution
- Galvanised steel
- Easy handling
- Brackets pre-bent in the factory
- For various applications
- Assembly rail as a universal solution for special bracket shapes

Connections in exposed installation with RAUTITAN elbows

- For the connection to the assembly elements
- For gypsum plasterboards
- For flush-mounted flushing tanks
- For chipboard facing



Fig. 10-2 RAUTITAN elbow with insulating box Rp $\frac{1}{2}$

RAUTITAN elbow for assembly on the bracket range

- In various sizes and lengths
- With different connecting threads
- Each attachable with 45° left or right offset
- Insulating box for RAUTITAN Rp $\frac{1}{2}$ elbows



Fig. 10-3 Installation example: Installation rail

10.02 Surface mounting



Fig. 10-4 Pipe support channel



Fig. 10-5 Universal pipe RAUTITAN flex clipped into pipe support channel

- The universal pipe RAUTITAN stabil is particularly suitable for surface mounting:
 - Easy to bend
 - Resistant to deformation
- For surface mounting of REHAU flexible pipes (RAU-PE-Xa), we recommend the use of REHAU pipe support channels.



Benefits of using the pipe support channel with the flexible RAU-PE-Xa pipes:

- Increased resistance to deformation of the flexible pipes
- Uniform spacing of the pipe fastenings for all pipe sizes at intervals of 2.0 m
- Reduction of the thermal change in length
- Stabilises pipes against sagging and sideways bending
- Visually attractive installation in exposed areas with RAU-PE-Xa pipes
- Simple assembly
- Self-supporting, is clipped onto the pipe
- No additional fastening (e.g. cable ties, insulating tape) required

11 Connection of piping to the water heaters

11.01 Electrical instantaneous water heaters

The listed electrical instantaneous water heaters (see Tab. 11-1) can be combined with the RAUTITAN system according to the manufacturer's specifications. Please note the technical data of the respective device manufacturer (maximum pressure and maximum temperature during operation as well as when there are faults) and the maximum operating parameters of the RAUTITAN system.

Manufacturer	Description
Bosch	Tronic 4000
Bosch	Tronic 5000
Bosch	Tronic 8500
CLAGE	DBX Next
CLAGE	DCX Next
CLAGE	DEX Next
CLAGE	DSX Touch
Stiebel Eltron	DEL XX* SL Plus
Stiebel Eltron	DHE
Stiebel Eltron	DHE Connect
Vaillant	electronicVED
Vaillant	electronicVED plus
Vaillant	electronicVED exclusive

XX* = The respective power rating in kW is indicated here in the product description

Tab. 11-1 Electrical instantaneous water heaters which fit with RAUTITAN, version March 2022 (Germany), noncommittal first estimation, subject to technical modification from appliance provider

11.02 Gas instantaneous water heaters

Not all gas instantaneous water heaters are suitable for direct connection to plastic pipes. With these units, inadmissibly high pressures and temperatures can arise if a fault occurs.

Always observe the specifications of the equipment manufacturer.

Approval for the connection of gas instantaneous water heaters to the RAUTITAN universal system for drinking water and heating can only be issued by the equipment manufacturer.

11.03 Hot water tanks

The RAUTITAN universal system for drinking water and heating can be used for hot water tanks with a maximum water temperature of 70 °C in continuous operation.



Electrical instantaneous water heaters, gas instantaneous water heaters and other water heaters which are not approved in this Technical Information for use with the RAUTITAN universal system for drinking water and heating, must be approved by the respective manufacturer. The employed type of pipe and its field of application must be observed.

11.04 Solar thermal systems

The RAUTITAN universal system for drinking water and heating can be used for water heating with solar thermal systems at a maximum water temperature of 70 °C in continuous operation.

Suitable measures must be taken (e.g. mixer for regulating the hot water temperature) to ensure exceeding the temperature can be ruled out.

For this reason, the RAUTITAN system is only suitable for conveying drinking water with a regulated hot water temperature (max. 70 °C) from the mixer outlet.

12 Pressure test and purging

12.01 Guidelines for pressure test



The successful execution and documentation of a pressure test is a prerequisite for any warranty claims from the REHAU guarantee and the liability agreement with the German Central Association for Plumbing, Heating and Air Conditioning (ZVSHK).

§

Deviations to DIN EN 806 concerning the pressure and tightness test have to be agreed from the building owner and if necessary have to be stipulated by contract.

According to DIN EN 806-4, a pressure test must be conducted on the completed but not yet concealed piping before commissioning.

Statements on the system's leak-tightness derived from the pressure test (constant, decreasing, increasing) can only be asserted in a limited capacity.

- The leak-tightness of the system can only be checked by performing a visual examination of unconcealed lines.
- Micro leaks can only be located by performing a visual examination (water outlet or leak detection agent) at high pressure.

Subdividing the piping system into smaller test sections increases the examination accuracy.



All finished pipe and threaded connections that remain permanently inaccessible or concealed shall be tested during the pressure test.

After the pressure test, only fittings and connection components whose sealing surface is visibly in front of the finished wall (e.g. tiles, plaster) may be connected. These fitting connections must be checked for leaks after commissioning.

Following instructions are based on the information sheet „Dichtheitsprüfung von Trinkwasser-Installationen mit Druckluft; Inertgas oder Wasser“ from ZVSHK.

12.02 Leak test of drinking water installations with water

12.02.01 Preparing for pressure test with water

1. Piping needs to be accessible and shall not be concealed.
2. Dismount safety devices and meters as necessary and replace with pipes or pipe stoppers.
3. Fill the piping at the lowest point of the system with filtered drinking water until free of air.
4. Vent the extraction points until water escapes without air.
5. Use a pressure testing device with a measurement precision of 100 hPa (0.1 bar) for the pressure test.
6. Connect the pressure testing device to the lowest point on the drinking water installation.
7. Close all extraction points carefully.



The pressure test can be heavily influenced by temperature fluctuations in the piping system, e.g. a temperature change of 10 K can cause a pressure change of 500 hPa to 1000 hPa (or 0.5 to 1 bar).

Due to the pipe material properties (e.g. pipe elongation when there is increased pressurisation), the pressure can fluctuate during the pressure test.

The test pressure as well as the pressure progression which occurs during testing do not permit any sufficient conclusions as to the leak-tightness of the system. For this reason, the entire drinking water installation, as required in the standards, must be visually checked for leaks.

8. Ensure that the temperature remains as constant as possible during the pressure test.
9. Prepare the pressure test record (see page 41) and note the system data.

12.02.02 Pressure test for installations with RAUTITAN stabil and installations with RAUTITAN stabil pipes mixed with metal pipes

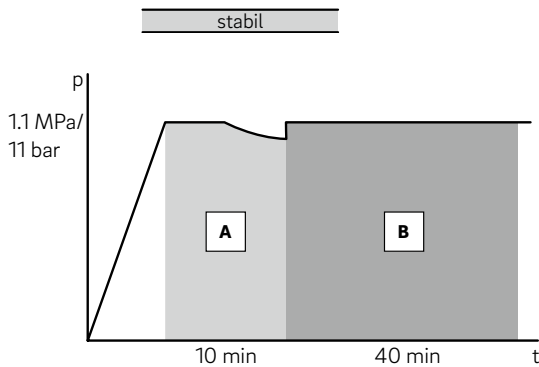

Fig. 12-1 Pressure test diagram based on ZVSHK-information sheet for RAUTITAN stabil

- A** Adaptation time (if necessary restore the pressure)
- B** Pressure test for installations with RAUTITAN stabil and installations with RAUTITAN stabil pipes mixed with metal pipes

1. Build up slowly the test pressure of 1.1 MPa (11 bar) in the drinking water installation.
2. If the difference between ambient temperature and water temperature is higher than 10 K than the pressure test can only begin after a waiting time of 30 minutes to achieve the temperature balance between the room and the water installation.
3. After 10 minutes read the test pressure and if necessary restore the pressure of 1.1 MPa (11 bar).
4. Note down the test pressure in the pressure test record.
5. After a test period of 30 more minutes, note down the test pressure in the pressure test record.
6. Perform visual checks for leaks on the entire drinking water installation, especially on the connection area.

If the test pressure is fallen:

- Repeat a thorough visual inspection of the installation, extraction points and joints.
 - After resolving the cause of the drop in pressure, repeat the pressure test (steps 1 – 6).
7. If no leaks are found during the visual check, than the pressure test can be ended.

12.02.03 Pressure test for installations with RAUTITAN flex and installations with RAUTITAN flex pipes mixed with RAUTITAN stabil pipes or metal pipes

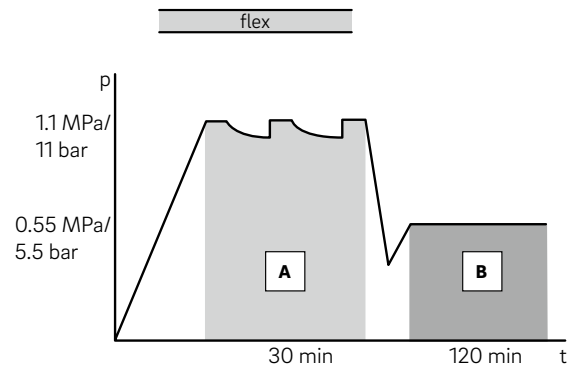

Fig. 12-2 Pressure test diagram based on ZVSHK-information sheet for RAUTITAN flex

- A** Adaptation time (if necessary restore the pressure)
- B** Pressure test for installations with RAUTITAN flex and installations with RAUTITAN flex pipes mixed with metal pipes

1. Build up slowly the test pressure of 1.1 MPa (11 bar) in the drinking water installation.
2. The test pressure has to be maintained at 11 bar during 30 minutes.
If necessary restore the test pressure regularly.
3. After 30 minutes, note down the test pressure in the pressure test record.
4. Check the entire drinking water installation, particularly the joints, for leaks by visual inspection.
5. Decrease slowly the test pressure from 1.1 MPa (11 bar) to 0.55 MPa (5.5 bar) and note it down in the pressure test record.
6. After a waiting time of 2 hours note down the test pressure in the pressure test record.
7. Check the entire drinking water installation, particularly the joints, for leaks by visual inspection.

If the test pressure is fallen:

- Repeat a thorough visual inspection of the piping, extraction points and joints.
 - After resolving the cause of the drop in pressure, repeat the pressure test (steps 1 – 7).
8. If no leaks are found during the visual check, than the pressure test can be ended.

12.02.04 Completion of the pressure test with water

After completion of the pressure test:

1. Confirm the pressure test in the pressure test record by the executing company and the client.
2. Dismount the pressure test unit.
3. After the pressure test, thoroughly rinse out the drinking water pipes for hygiene purposes (see chapter 12.04, page 40).
4. Reinstall all removed safety devices and meters.

12.03 Pressure test with oil free pressurised air or inert gas

Important information on tests with pressurised air and inert gas:

- Small leaks can only be detected using leak detection agents at high test pressures (load test) and the applicable visual inspection.
- Temperature fluctuations can affect the test result (pressure loss or increase).
- Pressurised air and inert gas are compressed gases. This means that the piping volume has a lot of influence on the shown pressure result. A high piping volume reduces the determination of small leaks using pressure reduction.



Leak detection agents

Only use leak detection agents (e.g. foaming agents) with current DVGW registration, which were also approved by the respective manufacturers for the PPSU and PVDF materials.

12.03.01 Preparing for pressure test with oil free pressurised air or inert gas

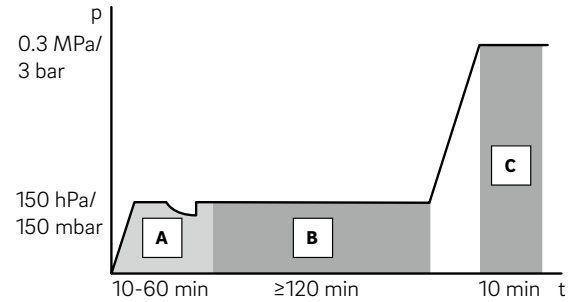

Fig. 12-3 Pressure test diagram for pressure test with pressure air or inert gas

- A** Adaption time, see Tab. 12-1
- B** Leak test
- C** Load test

Pipe volume	Adaption time ¹⁾	Test time ¹⁾
< 100 l	10 min	120 min
≥ 100 < 200 l	30 min	140 min
≥ 200 l	60 min	+ 20 min per 100 l

1) Approximate values, depending on the piping volume
Tab. 12-1 Pipe volume, adaption time and test time

1. Piping needs to be accessible and shall not be concealed.
2. Dismount safety devices and meters as necessary and replace them with pipes or pipe stoppers
3. Install enough air purges in appropriated places to allow a safe drain of the pressure air.
4. Use a pressure testing device for the pressure test.
5. Close all extraction points carefully.



The test pressure as well as the pressure progression which occurs during testing do not permit any sufficient conclusions as to the leak-tightness of the system. For this reason, the entire drinking water installation, as required in the standards, must be visually checked for leaks with leak detection agents.

6. Ensure that the temperature remains as constant as possible during the pressure test.
7. Prepare the pressure test record (see page 41) and note the system data.

12.03.02 Leak test

1. Choose the adaption and test time according to Tab. 12-1.
2. Use a pressure testing device with a measurement precision of 1 hPa (1 mbar) for the pressure test.
3. Build up slowly the test pressure of 150 hPa (150 mbar) in the drinking water installation. If necessary restore the test pressure after adaptation time.
4. The leak test begins after the adaptation time: Note down the test pressure and the test time in the pressure test record.
5. After the test time, note down the test pressure in the pressure test record.
6. Check the entire drinking water installation, particularly the joints, for leaks by visual inspection with leak detection agents.

If the test pressure is fallen:

- Repeat a thorough visual inspection of the piping, extraction points and joints.
 - After resolving the cause of the drop in pressure, repeat the pressure test.
7. If no leaks are found during the visual check, than note the visual inspection in the pressure test record.

12.03.03 Load test

1. Build up slowly the test pressure of 0.3 MPa (3 bar) in the drinking water installation.
2. Use a pressure testing device with a measurement precision of 100 hPa (0.1 bar) for the pressure test.
3. If necessary restore the test pressure after stabilisation of the pressure of 0.3 MPa (3 bar).
4. Note down the test pressure in the pressure test record.
5. After 10 minutes, note down the test pressure.
6. Perform visual checks for leaks on the entire drinking water installation, especially on the connection area.

If a leak has been detected during the visual inspection:

- Repair the piping and repeat the leak and load tests.
7. If no leak has been found during the visual check, than note the visual inspection in the pressure test record.
 8. After the load test, drain the pressure air in a secure way.
 9. 8. According to DIN EN 14291, residues of leak detection agents must be must be rinsed off with water.

12.03.04 Completion of the pressure test with pressurised air or inert gas

After completion of the pressure test:

1. Confirm the pressure test in the pressure test record by the executing company and the client.
2. Dismount the pressure test unit.
3. After the pressure test, thoroughly rinse out the drinking water pipes for hygiene purposes (see chapter 12.04, page 40).
4. Reinstall all removed safety devices and meters.

12.04 Purging drinking water pipes

According to DIN EN 806-4 and the ZVSHK-information sheet "Purge, disinfection and commissioning of drinking water installations" dirt from the storage and construction phase has to be flushed out.

For that all extraction points have to be opened in a defined order und for several minutes.

According to DIN EN 14291, residues of leak detection agents must be rinsed off with water.

According to DIN EN 806-4, the time-consuming purging of the piping with a mixture of air and water is an alternative to a purge with drinking water. But according to ZVSHK information sheet "Purge, disinfection and commissioning of drinking water installations" it only applies if the purging with drinking water isn't enough efficient or if coarse dirt is visible in the piping.

For hygiene reasons or if frost can occur we recommend to fully drain drinking water installation, if this one can not be immediately put into operation. Purge the drained system thoroughly before commissioning. According to DIN EN 806-4, the purge of the installation has to be periodically repeated for hygiene reasons if water has to stay in the piping a long time before commissioning.

12.05 Pressure test record: REHAUS's RAUTITAN system (drinking water installation)

The forms of a pressure test record for a pressure test of a drinking water installation can be found on the following pages.

Pressure test record: REHAU's RAUTITAN system (drinking water installation). Test based on the ZVSHK information sheet

Form: Pressure test with water

1. System data

Building projekt: _____
 Client: _____
 Adress/House No.: _____
 Post Code/Town/City: _____

2. Pressure test

Use a pressure testing device with a measurement precision of 100 hPa (0.1 bar).

stabil	flex
Installation with RAUTITAN stabil (also mixed with metal pipes)	Installation with RAUTITAN flex (also mixed with RAUTITAN stabil or metal pipes)
ΔT _____ K ($\Delta T = T_{\text{ambient}} - T_{\text{water}}$)	Test pressure _____ MPa (maximal operating pressure 1 MPa x 1.1 = 1.1 MPa (11 bar))
Test pressure _____ MPa (maximal operating pressure 10 MPa x 1.1 = 1.1 MPa (11 bar))	Waiting time _____ min (min. waiting time 30 minutes)
Adaption time _____ min 10 minutes if $\Delta T \leq 10$ K 40 minutes if $\Delta T > 10$ K	Test pressure _____ MPa (maintain the test pressure of 1.1 MPa (11 bar), if necessary restore the test pressure regularly)
Test pressure _____ MPa (if necessary restore the test pressure of 1.1 MPa (11 bar))	
<input type="checkbox"/> Visual inspection on the entire drinking water installation, especially on the connection area completed and no leak detected	<input type="checkbox"/> Visual inspection on the entire drinking water installation, especially on the connection area completed and no leak detected
Test time _____ min (min. test time = 30 minutes)	Leak test
Pressure after 30 min _____ MPa	Test pressure _____ MPa (0.55 MPa (5.5 bar))
	Test time _____ min (120 min.)
	Pressure after 120 min _____ MPa

3. Comments

- Entire drinking water installation, especially joints, checked visually for leak-tightness and no leaks found.
 The entire drinking water installation is leak-tight.

4. Confirmed

For the client: _____ For the contractor: _____

Town/City: _____ Date: _____

Attachments: _____

Pressure test record: REHAU's RAUTITAN system (drinking water installation). Test based on the ZVSHK information sheet

Form: Pressure test with air or inert gas

1. System data

Building projekt: _____
 Client: _____
 Adress/House No.: _____
 Post Code/Town/City: _____

2. Leak test

Use a pressure testing device with a measurement precision of 1 hPa (1 mbar).

Test medium: Oil free pressure air Azote Carbon dioxyde _____

2.1 Test pressure _____ mbar (150 mbar = 150 hPa)

2.2 Piping volume _____ l

2.3 Adaption time _____ min.

2.4 Current pressure _____ mbar (150 mbar = 150 hPa)

2.5 Test time _____ min.

2.6 Current pressure _____ mbar (150 mbar = 150 hPa)

Piping volume	Adaption time ¹⁾	Test time ¹⁾
< 100 l	10 min	120 min
≥ 100 < 200 l	30 min	140 min
≥ 200 l	60 min	+ 20 min per 100 l

1) Approximate values, depending on the piping volume

Visual inspection with leak detection agents on the entire drinking water installation, especially on the connection area completed and no leak detected.

3. Load test

Use a pressure testing device with a measurement precision of 100 hPa (0.1 bar)

3.1 Test pressure _____ MPa (0.3 MPa (3 bar))

3.2 Current pressure after 10 min _____ MPa

3.3 Comments:

Visual inspection with leak detection agents on the entire drinking water installation, especially on the connection area completed and no leak detected.

The entire drinking water installation is leak-tight.

4. Confirmed

For the client: _____ For the contractor: _____

Town/City: _____ Date: _____

Attachments: _____



13 Resistance coefficients and Pressure loss tables



The comparison or use of individual pipe pressure losses or resistance coefficients does not replace a pipe network calculation of the entire system.

13.01 Resistance coefficients (zeta values ζ) of the REHAU RAUTITAN fittings according to DVGW W 575 (extract)

No.	Fittings ¹⁾	Short sign acc. DVGW W 575	Graphica ²⁾ , simplified representation	Resistance coefficient ζ						
				Pipe outer diameter d_a [mm]						
				16 DN 12	20 DN 15	25 DN 20	32 DN 25	40 DN 32	50 DN 40	63 DN 50
1	T-piece RAUTITAN equal passage with flow separation	TA		3.8	3.6	4.4	3.8	4.2	1.3	1.4
2	T-piece RAUTITAN equal branch with flow separation	TD		1.0	0.9	1.1	0.9	1.0	0.2	0.2
3	T-piece RAUTITAN equal up-cut with flow separation	TG		3.9	3.8	4.5	3.9	4.4	1.1	1.3
4	T-piece RAUTITAN equal up-cut with flow conjunction	TVA		9.0	8.0	8.6	6.3	7.2	1.7	1.7
5	T-piece RAUTITAN equal branch with flow conjunction	TVD		17.3	13.5	16.4	12.2	14.2	2.9	3.1
6	T-piece RAUTITAN equal up-cut with flow conjunction	TVG		9.8	9.2	9.6	7.3	8.5	1.9	1.8
7	Elbow 90°	W90		3.7	3.6	4.1	3.6	4.2	-	-
8	Bend 90°	W90		0.9	0.5	0.6	0.5	-	0.7	0.6
9	Elbow 45°	W45		-	1.2	1.8	1.1	1.7	0.4	0.4
10	Reducing coupling (reduced by one dimension)	RED		0.6	0.6	0.6	0.6	0.5	0.2	-

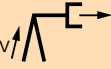
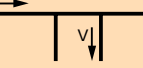
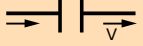
No.	Fittings ¹⁾	Short sign acc. DVGW W 575	Graphica ²⁾ , simplified representation	Resistance coefficient ζ						
				Pipe outer diameter d_a [mm]						
				16 DN 12	20 DN 15	25 DN 20	32 DN 25	40 DN 32	50 DN 40	63 DN 50
11	Wall plate elbow	WS		1.5	1.6	1.5	-	-	-	-
12	Wall plate elbow with passage passage	WSD		1.4	1.1	2.8	-	-	-	-
13	Wall plate elbow with passage branch	WSA		1.8	1.9	3.5	-	-	-	-
14	Manifold with compression sleeve branches	STV		1.0	1.1	-	-	-	-	-
15	Straight coupling (unreduced)	K		0.6	0.6	0.7	0.6	0.6	0.2	0.1

1) For reduced T-piece, the resistance coefficient of a T-piece equal with the smallest size is used

2) The symbol v for flow velocity indicates the reference flow in the fitting

The resistance coefficients (ζ values) of the table are only an extract of the RAUTITAN fitting product range. The resistance coefficients of the complete product range have been integrated to the REHAU planingsoftware. The resistance coefficients of individual fittings RAUTITAN PX, RAUTITAN RX+ and RAUTITAN SX are available on request.

14 Resistance coefficients and Pressure loss tables



The comparison or use of individual pipe pressure losses or resistance coefficients does not replace a pipe network calculation of the entire system.

14.01 Resistance coefficients (zeta values ζ) of the REHAU RAUTITAN fittings according to DVGW W 575 (extract)

No.	Fittings ¹⁾	Short sign acc. DVGW W 575	Graphica ²⁾ . simplified representation	Resistance coefficient ζ						
				Pipe outer diameter d_a [mm]						
				16 DN 12	20 DN 15	25 DN 20	32 DN 25	40 DN 32	50 DN 40	63 DN 50
1	T-piece RAUTITAN equal passage with flow separation	TA		3.8	3.6	4.4	3.8	4.2	1.3	1.4
2	T-piece RAUTITAN equal branch with flow separation	TD		1.0	0.9	1.1	0.9	1.0	0.2	0.2
3	T-piece RAUTITAN equal up-cut with flow separation	TG		3.9	3.8	4.5	3.9	4.4	1.1	1.3
4	T-piece RAUTITAN equal up-cut with flow conjunction	TVA		9.0	8.0	8.6	6.3	7.2	1.7	1.7
5	T-piece RAUTITAN equal branch with flow conjunction	TVD		17.3	13.5	16.4	12.2	14.2	2.9	3.1
6	T-piece RAUTITAN equal up-cut with flow conjunction	TVG		9.8	9.2	9.6	7.3	8.5	1.9	1.8
7	Elbow 90°	W90		3.7	3.6	4.1	3.6	4.2	0.7	0.6
8	Elbow 45°	W45		-	1.2	1.8	1.1	1.7	0.4	0.4
9	Reducing coupling (reduced by one dimension)	RED		0.6	0.6	0.6	0.6	0.5	0.2	-

No.	Fittings ¹⁾	Short sign acc. DVGW W 575	Graphica ²⁾ . simplified representation	Resistance coefficient ζ						
				Pipe outer diameter d_a [mm]						
				16 DN 12	20 DN 15	25 DN 20	32 DN 25	40 DN 32	50 DN 40	63 DN 50
10	Wall plate elbow	WS		1.5	1.6	1.5	-	-	-	-
11	Wall plate elbow with passage passage	WSD		1.4	1.1	2.8	-	-	-	-
12	Wall plate elbow with passage branch	WSA		1.8	1.9	3.5	-	-	-	-
13	Manifold with compression sleeve branches	STV		1.0	1.1	-	-	-	-	-
14	Straight coupling (unreduced)	K		0.6	0.6	0.7	0.6	0.6	0.2	0.1

1) For reduced T-piece. the resistance coefficient of a T-piece equal with the smallest size is used

2) The symbol v for flow velocity indicates the reference flow in the fitting

The resistance coefficients (ζ values) of the table are only an extract of the RAUTITAN fitting product range. The resistance coefficients of the complete product range have been integrated to the REHAU planingsoftware. The resistance coefficients of individual fittings RAUTITAN PX. RAUTITAN LX and RAUTITAN SX are available on request.

14.02 Pressure loss table: Drinking water installation RAUTITAN stabil 16–40

stabil

Water temperature: 10 °C

RAUTITAN stabil V̇ l/s	16.2 x 2.6		20 x 2.9		25 x 3.7		32 x 4.7		40 x 6.0	
	R hPa/m	v m/s	R hPa/m	v m/s	R hPa/m	v m/s	R hPa/m	v m/s	R hPa/m	v m/s
0.10	16.5	1.1	4.9	0.6	1.8	0.4	0.5	0.2	0.2	0.2
0.15	33.7	1.6	9.9	0.9	3.6	0.6	1.1	0.4	0.4	0.2
0.20	56.2	2.1	16.5	1.3	5.9	0.8	1.8	0.5	0.6	0.3
0.25	83.8	2.6	24.4	1.6	8.7	1.0	2.6	0.6	1.0	0.4
0.30	116.4	3.2	33.8	1.9	12.0	1.2	3.6	0.7	1.3	0.5
0.35	153.8	3.7	44.5	2.2	15.8	1.4	4.8	0.9	1.7	0.6
0.40	196.0	4.2	56.6	2.5	20.1	1.6	6.0	1.0	2.2	0.6
0.45	243.0	4.7	70.0	2.8	24.8	1.8	7.4	1.1	2.7	0.7
0.50	294.7	5.3	84.6	3.2	29.9	2.1	9.0	1.2	3.2	0.8
0.55	351.1	5.8	100.6	3.5	35.5	2.3	10.6	1.4	3.8	0.9
0.60	412.1	6.3	117.8	3.8	41.5	2.5	12.4	1.5	4.4	1.0
0.65	477.7	6.8	136.3	4.1	47.9	2.7	14.3	1.6	5.1	1.1
0.70	-	-	156.1	4.4	54.8	2.9	16.3	1.7	5.8	1.1
0.75	-	-	177.0	4.7	62.1	3.1	18.5	1.9	6.6	1.2
0.80	-	-	199.3	5.1	69.8	3.3	20.8	2.0	7.4	1.3
0.85	-	-	222.7	5.4	77.9	3.5	23.2	2.1	8.2	1.4
0.90	-	-	247.4	5.7	86.5	3.7	25.7	2.2	9.1	1.5
0.95	-	-	273.3	6.0	95.4	3.9	28.3	2.4	10.0	1.5
1.00	-	-	300.5	6.3	104.8	4.1	31.0	2.5	11.0	1.6
1.10	-	-	-	-	124.8	4.5	36.9	2.7	13.1	1.8
1.20	-	-	-	-	146.3	4.9	43.2	3.0	15.3	1.9
1.30	-	-	-	-	169.5	5.3	49.9	3.2	17.7	2.1
1.40	-	-	-	-	-	-	57.1	3.5	20.2	2.3
1.50	-	-	-	-	-	-	64.8	3.7	22.9	2.4
1.60	-	-	-	-	-	-	72.9	4.0	25.7	2.6
1.70	-	-	-	-	-	-	81.5	4.2	28.7	2.8
1.80	-	-	-	-	-	-	90.4	4.5	31.8	2.9
1.90	-	-	-	-	-	-	99.9	4.7	35.1	3.1
2.00	-	-	-	-	-	-	109.8	5.0	38.5	3.2
2.20	-	-	-	-	-	-	-	-	45.8	3.6
2.40	-	-	-	-	-	-	-	-	53.7	3.9
2.60	-	-	-	-	-	-	-	-	62.2	4.2
2.80	-	-	-	-	-	-	-	-	71.3	4.5
3.00	-	-	-	-	-	-	-	-	80.9	4.9
3.20	-	-	-	-	-	-	-	-	91.2	5.2

14.03 Pressure loss table: Drinking water installation RAUTITAN stabil 50–63

stabil

Water temperature: 10 °C

RAUTITAN stabil \dot{V} l/s	50 x 4.5		63 x 6.0	
	R hPa/m	v m/s	R hPa/m	v m/s
1.00	1.8	0.8	0.6	0.5
1.20	2.4	0.9	0.9	0.6
1.40	3.2	1.1	1.1	0.7
1.60	4.1	1.2	1.4	0.8
1.80	5.0	1.4	1.8	0.9
2.00	6.1	1.5	2.1	1.0
2.20	7.2	1.7	2.5	1.1
2.40	8.4	1.8	2.9	1.2
2.60	9.7	2.0	3.4	1.3
2.80	11.1	2.1	3.9	1.4
3.00	12.6	2.3	4.4	1.5
3.20	14.2	2.4	4.9	1.6
3.40	15.8	2.6	5.5	1.7
3.60	17.6	2.7	6.1	1.8
3.80	19.4	2.9	6.7	1.9
4.00	21.3	3.0	7.4	2.0
4.20	23.3	3.2	8.1	2.1
4.40	25.3	3.3	8.8	2.2
4.60	27.5	3.5	9.5	2.3
4.80	29.7	3.6	10.3	2.3
5.00	32.0	3.8	11.1	2.4
5.20	34.4	3.9	11.9	2.5
5.40	36.9	4.1	12.7	2.6
5.60	39.4	4.2	13.6	2.7
5.80	42.1	4.4	14.5	2.8
6.00	44.8	4.5	15.4	2.9
6.20	47.6	4.7	16.4	3.0
6.40	50.4	4.8	17.4	3.1
6.60	53.4	5.0	18.4	3.2
7.00			20.5	3.4
7.40			22.6	3.6
7.80			24.9	3.8
8.20			27.3	4.0
8.60			29.8	4.2
9.00			32.5	4.4
9.40			35.2	4.6
9.80			38.0	4.8
10.20			40.9	5.0

14.04 Pressure loss table: Drinking water installation RAUTITAN flex 16–25 flex

Water temperature: 10 °C

RAUTITAN flex \dot{V} l/s	16 x 2.2 DN 12		20 x 2.8 DN 15		25 x 3.5 DN 20	
	R hPa/m	v m/s	R hPa/m	v m/s	R hPa/m	v m/s
0.05	3.9	0.5	1.4	0.3	0.5	0.20
0.10	12.8	0.9	4.6	0.6	1.6	0.4
0.15	26.1	1.4	9.3	0.9	3.2	0.6
0.20	43.5	1.9	15.4	1.2	5.3	0.8
0.25	64.8	2.4	22.8	1.5	7.8	1.0
0.30	89.9	2.8	31.6	1.8	10.8	1.2
0.35	118.8	3.3	41.6	2.1	14.2	1.4
0.40	151.3	3.8	52.9	2.5	18.0	1.6
0.45	187.4	4.3	65.4	2.8	22.2	1.8
0.50	227.2	4.7	79.1	3.1	26.8	2.0
0.55	270.5	5.2	94.0	3.4	31.8	2.2
0.60	317.3	5.7	110.1	3.7	37.2	2.4
0.65	367.7	6.2	127.3	4.0	43.0	2.6
0.70	–	–	145.8	4.3	49.2	2.8
0.75	–	–	165.3	4.6	55.7	2.9
0.80	–	–	186.1	4.9	62.6	3.1
0.85	–	–	208.0	5.2	69.9	3.3
0.90	–	–	231.0	5.5	77.5	3.5
0.95	–	–	255.2	5.8	85.5	3.7
1.00	–	–	280.5	6.1	93.9	3.9
1.10	–	–	–	–	111.8	4.3
1.20	–	–	–	–	131.1	4.7
1.30	–	–	–	–	151.8	5.1

14.05 Pressure loss table: Drinking water installation RAUTITAN flex 32–40

flex

Water temperature: 10 °C

RAUTITAN flex \dot{V} l/s	32 x 4.4 DN 25		40 x 5.5 DN 32	
	R hPa/m	v m/s	R hPa/m	v m/s
0.1	0.5	0.2	0.2	0.2
0.5	7.9	1.2	2.7	0.8
1.0	27.3	2.4	9.3	1.5
1.5	52.0	3.5	19.3	2.3
2.0	96.5	4.7	32.5	3.0
2.2	115.0	5.2	38.6	3.3
2.4	–	–	45.3	3.6
2.6	–	–	52.4	3.9
2.8	–	–	60.1	4.2
3.0	–	–	68.2	4.5
3.2	–	–	76.8	4.8
3.4	–	–	85.8	5.1



RAUTITAN universal system for heating

Contents

15	Area of application	54		
15.01	RAUTITAN connection components for heating installation	54		
16	Area of application	55		
16.01	RAUTITAN connection components for heating installation	55		
17	Area of application	56		
17.01	RAUTITAN connection components for heating installation	56		
17.02	Oxygen-tightness	57		
17.03	Standards and guidelines	57		
17.04	Requirements of the heating water	57		
17.05	Requirements of the hot water heating systems	57		
17.06	Solar thermal systems	57		
18	System parameters	58		
18.01	Supply and return temperatures	58		
18.02	Fluctuating heating operation	58		
18.03	Constant heating operation	58		
18.04	Maximum operation (special applications)	59		
19	Radiator connection from the floor	60		
19.01	Radiator connection bend set stainless steel to valve-regulated radiators	61		
19.02	Radiator connection bend set CU/brass to valve-regulated radiators	61		
19.03	Radiator connection tee RAUTITAN to valve-regulated radiators	62		
19.04	Direct connection with the RAUTITAN stabil universal pipe to valve-regulated radiators	63		
19.05	Direct connection with the universal pipe RAUTITAN flex and radiator connection set to valve-regulated radiators	63		
19.06	Radiator connection bend RAUTITAN to compact radiators	64		
19.07	Radiator connection tee RAUTITAN to compact radiators	64		
20	Radiator connection from the wall	65		
20.01	Radiator connection bend RAUTITAN stainless steel to valve-regulated radiators	66		
20.02	Radiator connection block RAUTITAN stabil to valve-regulated radiators	67		
20.03	Heating installation unit RAUTITAN to valve-regulated radiators	68		
20.04	Direct connection with the universal pipe RAUTITAN stabil to valve-regulated radiators	68		
20.05	Radiator connection bend RAUTITAN to compact radiators	69		
20.06	Direct connection with adapter with male thread RAUTITAN to compact radiators	69		
			21	Connections with radiator bend
			21.01	Connection features
			21.02	Screw connections
			21.03	Guidelines
			21.04	Expanding the radiator connection bends or tees RAUTITAN
			21.05	Fastening radiator connection bends RAUTITAN
			21.06	Installation procedure for radiator connection bends RAUTITAN – Example
			22	Connection with manifold union
			22.01	Characteristics of the connection process
			22.02	Installation procedure for manifold union RAUTITAN – Example
			23	Heating components
			23.01	Ball valve block
			23.02	Connection nipple set G ½ x G ¾
			24	Additional system accessories
			24.01	Cross fitting RAUTITAN
			24.02	Heating pipe manifold stainless steel
			24.03	Double rosette
			24.04	Compression sleeve manifold
			24.05	Heat meter adapter set
			24.06	Manifold cabinets
			25	Radiator connection from skirting
			25.01	Application
			25.02	Radiator connection from the skirting
			25.03	Telescopic corner screw joint set
			25.04	Installation of the skirting connection sets RAUTITAN
			25.05	General notes on the skirting trunking
			26	Pressure Test of heating pipe
			26.01	Guidelines for pressure test
			26.02	Purging heating pipes
			26.03	Pressure test record: REHAU's RAUTITAN system (heating installation)

27	Pressure loss tables	87
27.01	Piping network calculation	87
27.02	Overview of the pressure loss tables	87
27.03	Notes on using the 1 K-table when calculating the pressure loss	87
27.04	Pressure loss table: Heating installation (spread 1 K)	89
27.05	Pressure loss table: Heating installation RAUTITAN stabil 16.2 x 2.6 (spread 10, 15 and 20 K)	91
27.06	Pressure loss table: Heating installation RAUTITAN stabil 20 x 2.9 (spread 10, 15 and 20 K)	92
27.07	Pressure loss table: Heating installation RAUTITAN stabil 25 x 3.7 (spread 10, 15 and 20 K)	94
27.08	Pressure loss table: Heating installation RAUTITAN stabil 32 x 4.7 (spread 10, 15 and 20 K)	95
27.09	Pressure loss table: Heating installation RAUTITAN stabil 40 x 6.0 (spread 10, 15 and 20 K)	97
27.10	Pressure loss table: Heating installation RAUTITAN stabil 50 x 4.5 (spread 10, 15 and 20 K)	99
27.11	Pressure loss table: Heating installation RAUTITAN stabil 63 x 6.0 (spread 10, 15 and 20 K)	101
27.12	Pressure loss table: Heating installation RAUTITAN flex 16 x 2.2 (spread 10, 15 and 20 K)	103
27.13	Pressure loss table: Heating installation RAUTITAN flex 20 x 2.8 (spread 10, 15 and 20 K)	104
27.14	Pressure loss table: Heating installation RAUTITAN flex 25 x 3.5 (spread 10, 15 and 20 K)	105
27.15	Pressure loss table: Heating installation RAUTITAN flex 32 x 4.4 (spread 10, 15 and 20 K)	106
27.16	Pressure loss table: Heating installation RAUTITAN flex 40 x 5.5 (spread 10, 15 and 20 K)	107





15 Area of application

15.01 RAUTITAN connection components for heating installation

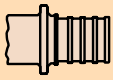
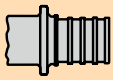
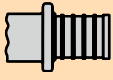

Fig. 15-1 RAUTITAN pipes for the heating installation

RAUTITAN connection components for heating installation

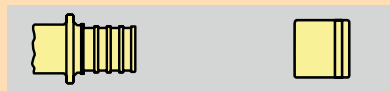
Size	Pipes	Fittings	Compression sleeves
16	<div style="border: 1px solid black; width: 100px; height: 10px; margin: 5px auto; text-align: center;">flex</div> Universal pipe RAUTITAN flex	 RAUTITAN PX	 RAUTITAN PX
20		 RAUTITAN RX+	
25		 RAUTITAN SX	
32		<div style="border: 1px solid black; width: 100px; height: 10px; margin: 5px auto; text-align: center;">stabil</div> Universal pipe RAUTITAN stabil	
40	-	 RAUTITAN SX stabil	 RAUTITAN PX stabil
50		Connection components for the radiator connection from the skirting	
63		<div style="border: 1px solid black; width: 100px; height: 10px; margin: 5px auto; text-align: center;">stabil</div> Universal pipe RAUTITAN stabil	 Skirting fitting sets





16 Area of application

16.01 RAUTITAN connection components for heating installation

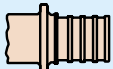

Fig. 16-1 RAUTITAN pipes for the heating installation

RAUTITAN connection components for heating installation

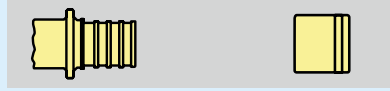
Size	Pipes	Fittings	Compression sleeves	
16	<div style="border: 1px solid black; padding: 2px; display: inline-block; margin-bottom: 5px;">stabil</div> Universal pipe RAUTITAN stabil	 RAUTITAN PX	 RAUTITAN PX	
20		 RAUTITAN RX+		
25		<div style="border: 1px solid black; padding: 2px; display: inline-block; margin-bottom: 5px;">flex</div> Universal pipe RAUTITAN flex		 RAUTITAN SX
32		-		 RAUTITAN RX+
40				
50				
63				
Connection components for the radiator connection from the skirting				
16	<div style="border: 1px solid black; padding: 2px; display: inline-block; margin-bottom: 5px;">stabil</div> Universal pipe RAUTITAN stabil	 Skirting fitting sets		
20				









17 Area of application

17.01 RAUTITAN connection components for heating installation



Fig. 17-1 RAUTITAN pipes for the heating installation

RAUTITAN connection components for heating installation

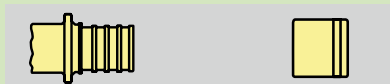
Size	Pipes	Fittings	Compression sleeves
16	<div style="border: 1px solid black; padding: 2px; width: fit-content; margin: 0 auto;">flex</div> Universal pipe RAUTITAN flex	 RAUTITAN PX	 RAUTITAN PX
20		 RAUTITAN LX + G	
25		 RAUTITAN LX RAUTITAN RX+	
32		 RAUTITAN SX	
40	<div style="border: 1px solid black; padding: 2px; width: fit-content; margin: 0 auto;">stabil</div> Universal pipe RAUTITAN stabil	 RAUTITAN RX+ stabil	 RAUTITAN PX stabil
50		 RAUTITAN SX stabil	
63			
Connection components for the radiator connection from the skirting			
16	<div style="border: 1px solid black; padding: 2px; width: fit-content; margin: 0 auto;">stabil</div> Universal pipe RAUTITAN stabil	 Skirting fitting sets	
20			

17.02 Oxygen-tightness

- The universal pipe RAUTITAN stabil is impervious to oxygen thanks to its layer of aluminium.
- The universal pipe RAUTITAN flex consists of RAU-PE-Xa with an oxygen diffusion barrier and are oxygen-tight in accordance with DIN 4726.

17.03 Standards and guidelines

DIN CERTCO

DIN CERTCO registration confirms the suitability of RAU-PE-Xa pipes in the heating installation in accordance with DIN 4726/ DIN EN ISO 15875 – application class 5 and the necessary tightness against oxygen diffusion for:

- Universal pipe RAUTITAN flex

Compression sleeve jointing technique

- Permanently sealing compression sleeve jointing technique according to DIN EN 806, DIN 1988 and DVGW worksheet W 534 with DVGW registration
- Suitable for flush-mounted installation or concealed in screed without inspection shaft or similar facilities as per DIN 18380 (VOB/C)



Do not mix up the RAUTITAN connection components with the underfloor heating/cooling connection components.

- Only use connection components of the RAUTITAN system in the heating installation.
 - Please note the measurements on the connection components.
 - You can find the precise assignment of the connection components in the current price list.
-

17.04 Requirements of the heating water

Properties of the heating water as specified in VDI 2035



The piping can be damaged when using inhibitors, antifreeze agents or other heating water additives. Approval must be obtained from the respective manufacturer and from our Applications Department.

In this case, please consult your REHAU sales office.

17.05 Requirements of the hot water heating systems

- Heating systems in buildings according to DIN EN 12828
- DIN EN 14336 heating systems in buildings – Installation and commissioning of water based heating systems

17.06 Solar thermal systems

The pipework with the RAUTITAN universal system for drinking water and heating between the reservoir and the solar collectors (primary circuit) is not permitted due to the high temperatures which can be expected.

18 System parameters

18.01 Supply and return temperatures

According to the rules for heating technology (e.g. DIN EN 442, radiators and convectors), the standard heat output is determined on the basis of a supply temperature of 75 °C and a return temperature of 65 °C for the heating water.

Due to switching differences in thermostats, losses in the piping network and the reduction of the temperatures in the heating circuit to save energy, a maximum supply temperature of 70 °C has become common practice. This is taken into account in the design tables of many renowned radiator manufacturers.



Radiator connection system skirting

Do not exceed the maximum supply temperature of 70 °C.

18.02 Fluctuating heating operation

Heating systems are not normally operated at a constant temperature over the entire service life of the system. The different operating parameters, e.g. due to summer and winter operation, are taken into account in the DIN EN ISO 15875 standard (Plastic piping systems for hot and cold water installations – crosslinked polyethylene PE-X) and DIN EN ISO 21003 (Multilayer piping systems for hot and cold water installations inside buildings). The assumed service life is divided in this standard into several periods of operation at different temperatures.

The following practical circumstances are taken into account:

- Summer and winter operation
- Variable temperature curves during the heating periods
- Service life: 50 years

The assumptions are shown below for the operating periods at different temperatures for an overall service life of 50 years by the example of a high-temperature radiator connection (application class 5 acc. ISO 10508).

Design temperature T [°C]	Service life Time t _D [years]	Pressure	
		stabil [MPa / bar]	flex [MPa / bar]
20	14	1 / 10	0.8 / 8
60	+ 25	1 / 10	0.8 / 8
80	+ 10	1 / 10	0.8 / 8
90	+ 1	1 / 10	0.8 / 8
Total	50 years		

Tab. 18-1 Temperature-pressure combinations for 50 years summer/winter operation (application class 5 acc. ISO 10508)

For the variable modes of operation with summer and winter operation, this results in the following maximum operating values:

- Short-term maximum temperature T_{max} : 90 °C (1 year within 50 years)
- Short-term malfunction temperature T_{mal} : 100 °C (100 hours in 50 years)
- Maximal operating pressure

stabil	flex
1 MPa / 10 bar	0.8 MPa / 8 bar
- Service life: 50 years

A typical field of operation for fluctuating heating operation is a low-temperature heating system.

18.03 Constant heating operation

For constant operation without the influence of summer and winter operation, the following system parameters cannot be exceeded:

Parameters	Value
Design temperature T_D	Maximum 70 °C
Operating pressure	Maximum 1 MPA / 10 bar
Service life	50 years

Tab. 18-2 System parameters for constant operation

18.04 Maximum operation (special applications)

In a heating application not designed for a service life of 50 years, the REHAU pipes can be operated at their maximum temperature and pressure combinations.

Pipe	Design temperature [C°]	Operating pressure (maximum) [MPa / bar]	Service life [years]
Universal pipe RAUTITAN stabil stabil	95	1 / 10	5
Universal pipe RAUTITAN flex flex	90	0.8 / 8	10

Tab. 18-3 Service life as combination of maximum temperature and pressure

19 Radiator connection from the floor

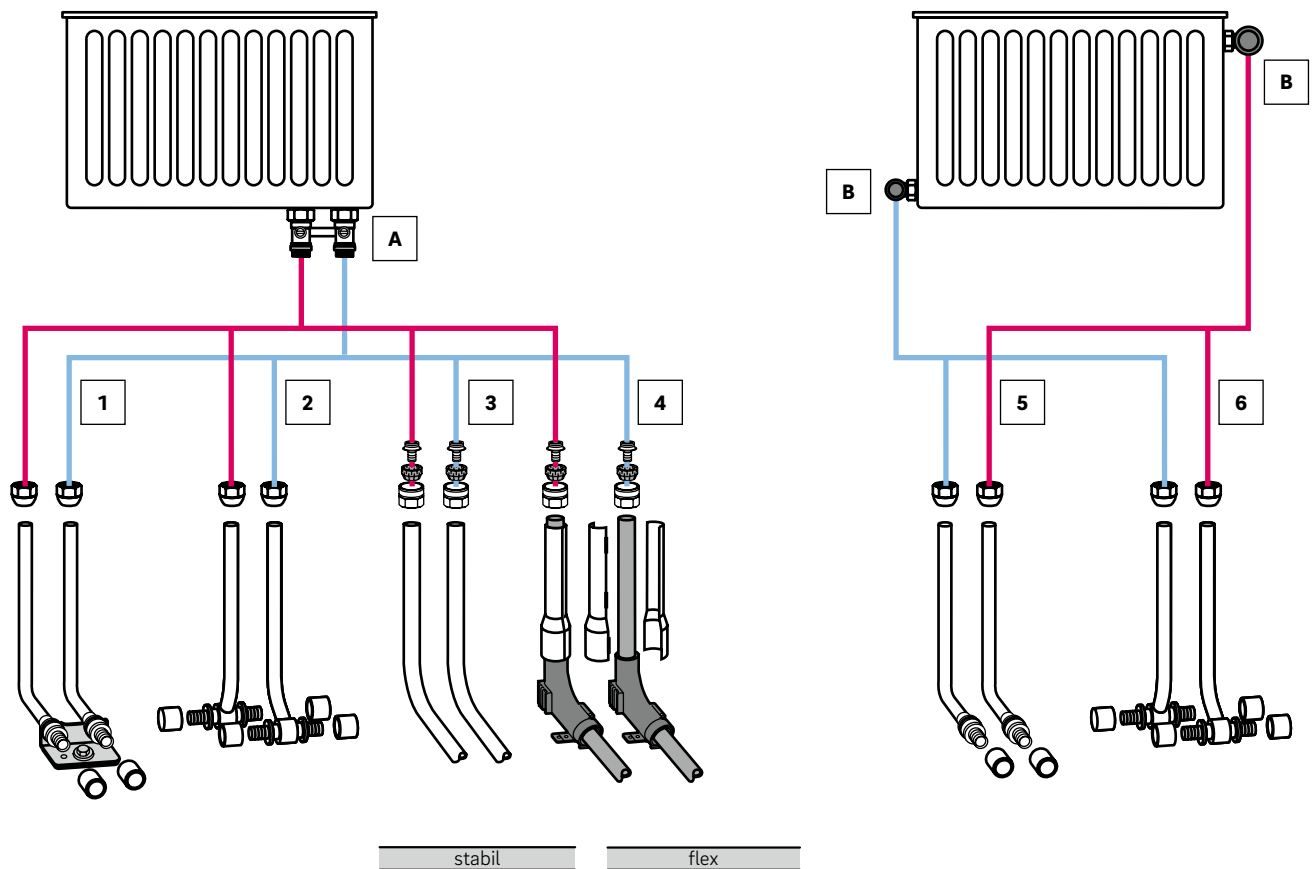

Fig. 19-1 Overview: Radiator connection from the floor

- A** Ball valve block, straight
- B** Common valves

Connection to valve-regulated radiators

- 1** Radiator connection bend set RAUTITAN
 - made of stainless steel (see chapter 19.01, page 61)
 - made of copper (see chapter 19.02, page 61)
- 2** Radiator connection tee RAUTITAN (see chapter 19.03, page 62)
- 3** Direct connection with the universal pipe RAUTITAN stabil (see chapter 19.04, page 63)
- 4** Direct connection with the universal pipe RAUTITAN flex (see chapter 19.05, page 63)

Connection to compact radiators

- 5** Radiator connection bend RAUTITAN (see chapter 19.06, page 64)
- 6** Radiator connection tee RAUTITAN (see chapter 19.07, page 64)

19.01 Radiator connection bend set stainless steel to valve-regulated radiators

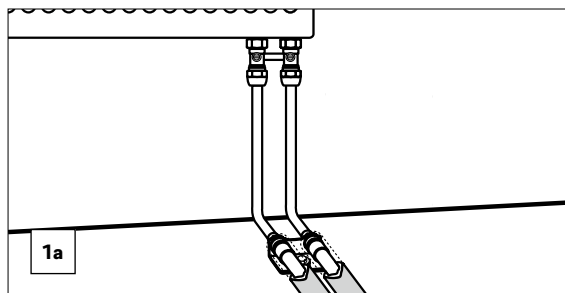

Fig. 19-2



Fig. 19-3

19.02 Radiator connection bend set CU/brass to valve-regulated radiators

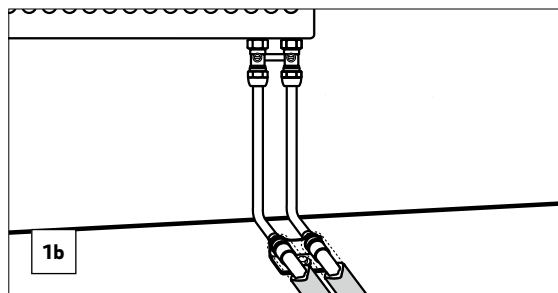

Fig. 19-4

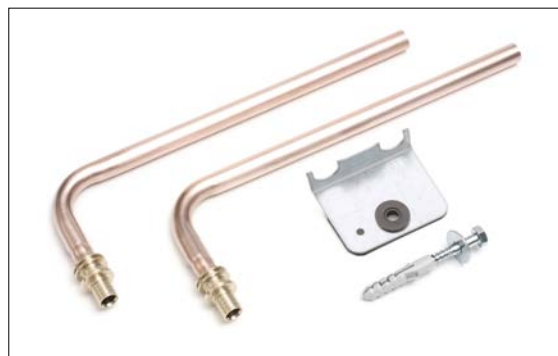

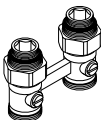



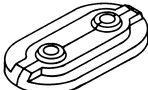

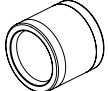

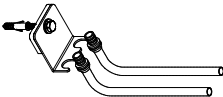

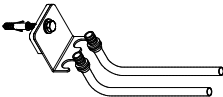

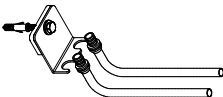

Fig. 19-5

Article	Amount	Article description	Material no.	Article no.
 	1	Ball valve block with connection nipple G ½ x G ¾, straight	12407271001	240727-001
 	2	Screw connection G ¾ - 15	12406011003	240601-003
 	1	Double rosette to cover radiator connecting pipes from the floor or from the wall, two-part, distance between centres: 50 mm Colour: White RAL 9010, size 15	12686741001	268674-001
 	2 or 2	Compression sleeve 16 RAUTITAN PX Compression sleeve 20 RAUTITAN PX	11600011001 11600021001	160001-001 160002-001
 	1	Radiator connection bend set RAUTITAN, stainless steel, including fixing unit, sizes 16/250	12663721001	266372-001
 	or 1	Radiator connection bend set RAUTITAN, stainless steel, including fixing unit, sizes 20/250	12663921001	266392-001
 	1	Radiator connection bend set CU/brass RAUTITAN, including fixing unit, size 16/250	12664121001	266412-001

Tab. 19-1

Achtung: Die erweiterte Materialnummer gilt für alle SAP-Länder

19.03 Radiator connection tee RAUTITAN to valve-regulated radiators

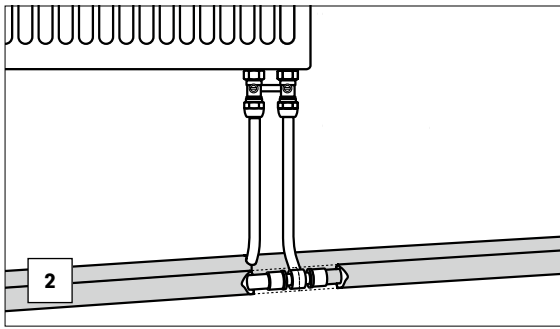

Fig. 19-6

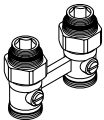

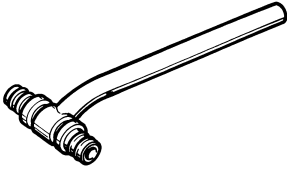
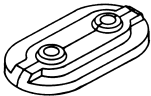
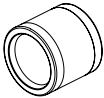

Fig. 19-7

§

According to the information sheets of the German association for screed and floor coverings (BEB) „Pipes, cables and cable ducts on rough floors, information for screed layers and planners, Part Screed techniques“, pipes must be routed at a minimum distance of 200 mm from walls.

When a ring pipeline is laid with the radiator connection tee RAUTITAN, this distance is not reached. If this laying variant is planned, we recommend a written agreement with the client before work is started.

Article	Amount	Article description	Material no.	Article no.
	1	Ball valve block with connection nipple G ½ x G ¾, straight	12407271001	240727-001
	2	Screw connection G ¾ - 15	12406011003	240601-003
	2	Radiator connection tee RAUTITAN 16 Length: 250 mm Length: 500 mm Length: 1000 mm	12662821001 12408511001 12662921001	266282-001 240851-001 266292-001
	or 2	Radiator connection tee RAUTITAN 20 Length: 250 mm Length: 500 mm Length: 1000 mm	12663021001 12408611001 12663121001	266302-001 240861-001 266312-001
	1	Double rosette to cover radiator connecting pipes from the floor or from the wall, two-part, distance between centres: 50 mm Colour: White RAL 9010, size 15	12686741001	268674-001
	4	Compression sleeve 16 RAUTITAN PX	11600011001	160001-001
	or 4	Compression sleeve 20 RAUTITAN PX	11600021001	160002-001

Tab. 19-2

19.04 Direct connection with the RAUTITAN stabil universal pipe to valve-regulated radiators

stabil

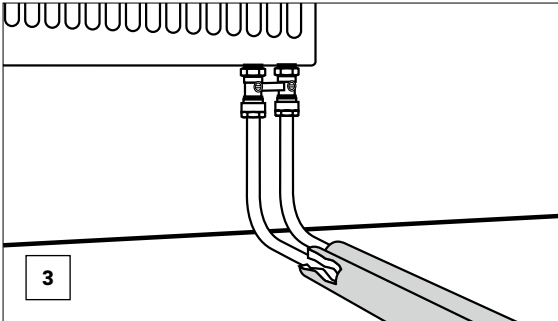

Fig. 19-8



Fig. 19-9

19.05 Direct connection with the universal pipe RAUTITAN flex and radiator connection set to valve-regulated radiators

flex

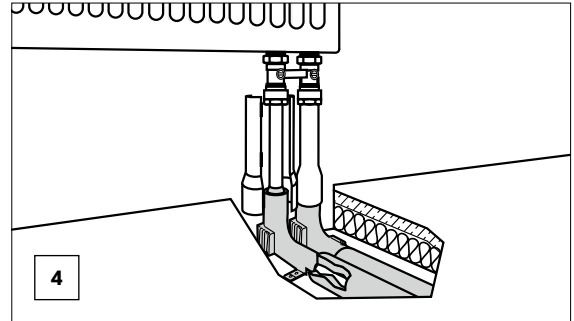
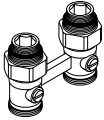
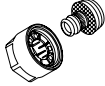
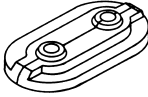

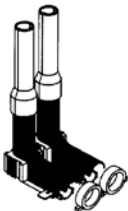

Fig. 19-10



Fig. 19-11

Article	Amount	Article description	Material no.	Article no.
	1	Ball valve block with connection nipple G 1/2 x G 3/4, straight	12407271001	240727-001
	2	Manifold union RAUTITAN stabil 16.2 x 2.6	12664521003	266452-003
	or			
	2	Manifold union RAUTITAN stabil 20 x 2.9	12664621003	266462-003
	1	Double rosette to cover radiator connecting pipes from the floor or from the wall, two-part, distance between centres: 50 mm Colour: White RAL 9010, size 16/20	12407771001	240777-001
	2	Manifold union RAUTITAN flex 16 x 2.2	12663521003	266352-003
	1	Radiator connection set	12658791001	265879-001

Tab. 19-3

Achtung: Die erweiterte Materialnummer gilt für alle SAP-Länder

19.06 Radiator connection bend RAUTITAN to compact radiators

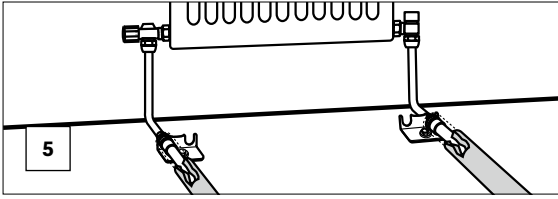

Fig. 19-12



Fig. 19-13

19.07 Radiator connection tee RAUTITAN to compact radiators

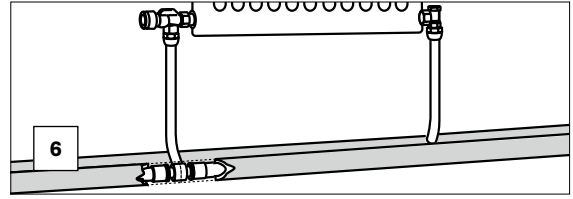

Fig. 19-14



Fig. 19-15

§

Legal information: refer to page 62.

Article	Amount	Article description	Material no.	Article no.
 	1	Connection nipple set G ½ x G ¾	12407111001	240711-001
 	2	Screw connection G ¾ - 15	12406011003	240601-003
 	2 (4 for version 6) or 2 (4 for version 6)	Compression sleeve 16 RAUTITAN PX or Compression sleeve 20 RAUTITAN PX	11600011001 11600021001	160001-001 160002-001
	2 or 2	Radiator connection bend RAUTITAN 16 Length: 250 mm Length: 500 mm Length: 1000 mm Radiator connection bend RAUTITAN 20 Length: 250 mm Length: 500 mm Length: 1000 mm	12662421001 12409311001 12662521001 12662621001 12409411001 12662721001	266242-001 240931-001 266252-001 266262-001 240941-001 266272-001
	2	Fixing unit, distance between centres 50 mm, with polymer base plate to reduce sound transmission, dowel 10 mm, galvanised hex screw SW (wrench size) 13 and washer	12404571002	240457-002
	2 or 2	Radiator connection tee RAUTITAN 16 Length: 250 mm Length: 500 mm Length: 1000 mm Radiator connection tee RAUTITAN 20 Length: 250 mm Length: 500 mm Length: 1000 mm	12662821001 12408511001 12662921001 12663021001 12408611001 12663121001	266282-001 240851-001 266292-001 266302-001 240861-001 266312-001

Tab. 19-4

Achtung: Die erweiterte Materialnummer gilt für alle SAP-Länder

20 Radiator connection from the wall

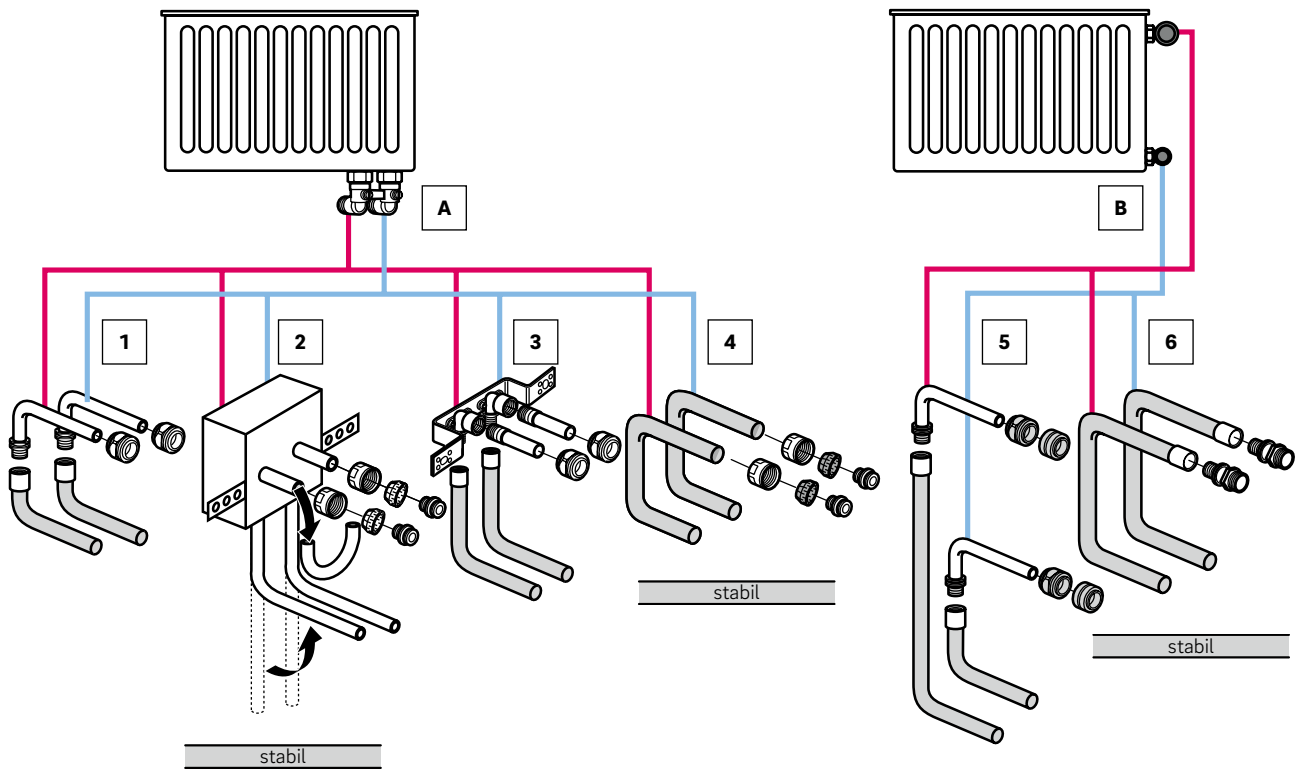

Fig. 20-1 Overview: Radiator connection from the wall

- A** Ball valve block (angled)
- B** Common valves

Connection sets to valve-related radiator

- 1** Radiator connection bend RAUTITAN made of stainless steel (see chapter 20.02, page 67)
- 2** Radiator connection block RAUTITAN stabil (see chapter 20.02, page 67)
- 3** Heating installation unit RAUTITAN (see chapter 20.03, page 68)
- 4** Direct connection with the universal pipe RAUTITAN stabil (see chapter 20.04, page 68)

Connection sets to compact radiators

- 5** Radiator connection bend RAUTITAN (see chapter 20.05, page 69)
- 6** Direct connection with adapter with male thread RAUTITAN (see chapter 20.06, page 69)



- Quick and easy floor cleaning
- Continuous floor covering
- Reduction of sealing joints in wet areas



20.01 Radiator connection bend RAUTITAN stainless steel to valve-regulated radiators

Fig. 20-2

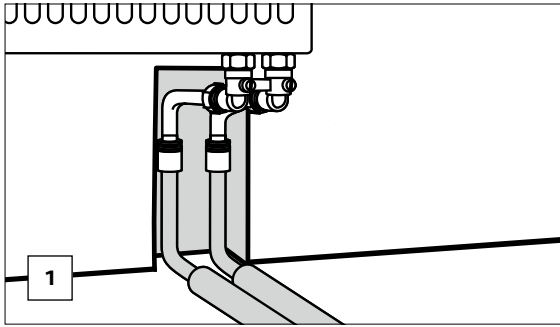
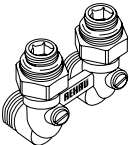

Fig. 20-3

Article	Amount	Article description	Material no.	Article no.
	1	Ball valve block with connection nipple G 1/2 x G 3/4, angled	12407371001	240737-001
	2	Screw connection G 3/4 - 15	12406011003	240601-003
	2 or 2	Radiator connection bend RAUTITAN 16/250 Radiator connection bend RAUTITAN 20/250	12662421001 12662621001	266242-001 266262-001
	1	Double rosette to cover radiator connecting pipes from the floor or from the wall, two-part, distance between centres: 50 mm Colour: White RAL 9010, size 15	12686741001	268674-001
	2 or 2	Compression sleeve 16 RAUTITAN PX Compression sleeve 20 RAUTITAN PX	11600011001 11600021001	160001-001 160002-001

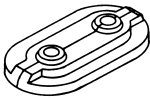
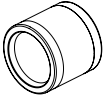
Tab. 20-1

Achtung: [Die erweiterte Materialnummer gilt für alle SAP-Länder](#)

20.02 Radiator connection block RAUTITAN stabil to valve-regulated radiators

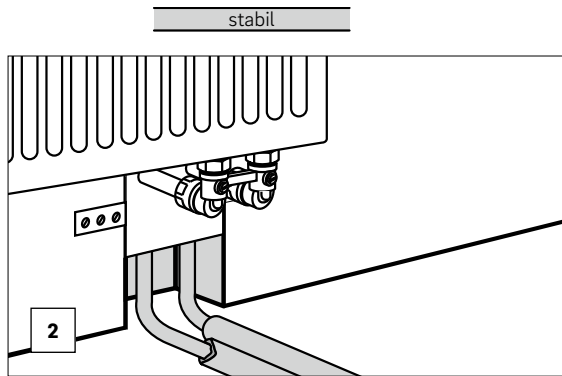

Fig. 20-4



Fig. 20-5





- Insulator free of CFC and halogens
- Heat insulation according to German Building Energy Law (GEG)
- With fastening strap
- Pressurising and test heating without radiators: Supply and return lines joined by pipe elbows
- Variable connection height
- System-tested screw connections and fittings
- Radiators can be installed after completion of plastering and painting work

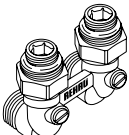

The bypass pipe for the radiator connection block RAUTITAN stabil is used only for pressure tests and in the test heating phase. For continuous heating operation, remove the bypass pipe and connect the intended valve-regulated radiator with the vent.

Cut the bypass pipe outside the bending radius so that the sealing parts of the manifold union are not in the curved part of the bypass pipe. This results in a maximum effective connecting pipe length of 140 mm starting from leading edge of the insulation box.

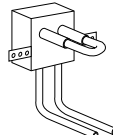
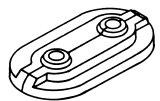
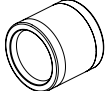
Article	Amount	Article description	Material no.	Article no.
	1	Ball valve block with connection nipple G ½ x G ¾, angled	12407371001	240737-001
	2	Manifold union RAUTITAN stabil 16.2 x 2.6	12664521003	266452-003
	1	Radiator connection block RAUTITAN stabil	11101981001	110198-001
	1	Double rosette to cover radiator connecting pipes from the floor or from the wall, two-part, distance between centres: 50 mm Colour: White RAL 9010, sizes 16/20	12407771001	240777-001
	2	Compression sleeve 16 RAUTITAN PX (with direct connection to RAUTITAN fittings, e.g. tee pieces)	11600011001	160001-001

Tab. 20-2

Achtung: [Die erweiterte Materialnummer gilt für alle SAP-Länder](#)

20.03 Heating installation unit RAUTITAN to valve-regulated radiators

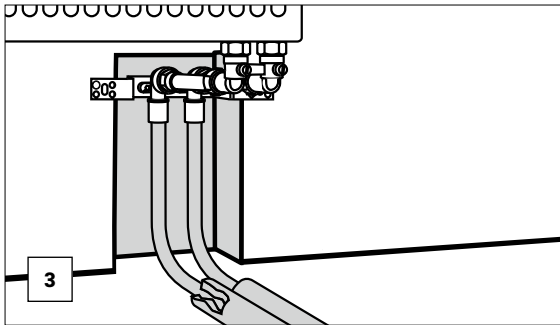

Fig. 20-6



Fig. 20-7

20.04 Direct connection with the universal pipe RAUTITAN stabil to valve-regulated radiators

stabil

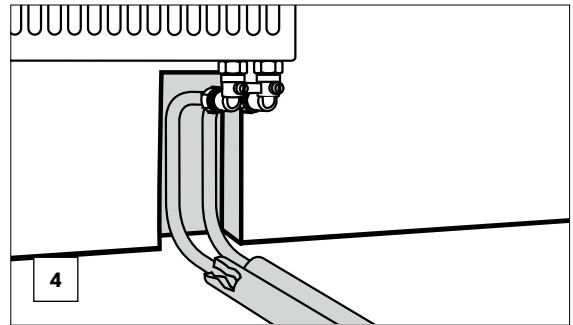

Fig. 20-8



Fig. 20-9

Article	Amount	Article description	Material no.	Article no.
<div style="display: flex; align-items: center;"> <div style="margin-right: 10px;"> <div style="border: 1px solid black; padding: 2px; width: 15px; height: 15px; display: flex; align-items: center; justify-content: center;">3</div> <div style="border: 1px solid black; padding: 2px; width: 15px; height: 15px; display: flex; align-items: center; justify-content: center;">4</div> </div> </div>	1	Ball valve block with connection nipple G 1/2 x G 3/4, angled	12407371001	240737-001
<div style="display: flex; align-items: center;"> <div style="margin-right: 10px;"> <div style="border: 1px solid black; padding: 2px; width: 15px; height: 15px; display: flex; align-items: center; justify-content: center;">3</div> <div style="border: 1px solid black; padding: 2px; width: 15px; height: 15px; display: flex; align-items: center; justify-content: center;">4</div> </div> </div>	1	Double rosette to cover radiator connecting pipes from the floor or from the wall, two-part, distance between centres: 50 mm Colour: White RAL 9010, size 15 mm	12686741001	268674-001
<div style="display: flex; align-items: center;"> <div style="margin-right: 10px;"> <div style="border: 1px solid black; padding: 2px; width: 15px; height: 15px; display: flex; align-items: center; justify-content: center;">3</div> </div> </div>	2	Screw connection G 3/4 - 15	12406011003	240601-003
<div style="display: flex; align-items: center;"> <div style="margin-right: 10px;"> <div style="border: 1px solid black; padding: 2px; width: 15px; height: 15px; display: flex; align-items: center; justify-content: center;">3</div> </div> </div>	2	Radiator connection pipe R 1/2 x 15, stainless steel	12613131001	261313-001
<div style="display: flex; align-items: center;"> <div style="margin-right: 10px;"> <div style="border: 1px solid black; padding: 2px; width: 15px; height: 15px; display: flex; align-items: center; justify-content: center;">3</div> </div> </div>	1	Heating installation unit RAUTITAN 16 x 2.2 - Rp 1/2	12409211401	240921-401
<div style="display: flex; align-items: center;"> <div style="margin-right: 10px;"> <div style="border: 1px solid black; padding: 2px; width: 15px; height: 15px; display: flex; align-items: center; justify-content: center;">3</div> </div> </div>	2	Compression sleeve 16 RAUTITAN PX	11600011001	160001-001
<div style="display: flex; align-items: center;"> <div style="margin-right: 10px;"> <div style="border: 1px solid black; padding: 2px; width: 15px; height: 15px; display: flex; align-items: center; justify-content: center;">4</div> </div> </div>	2	Manifold union RAUTITAN stabil 16.2 x 2.6	12664521003	266452-003
	or			
	2	Manifold union RAUTITAN stabil 20 x 2.9	12664621003	266462-003

Tab. 20-3

Achtung: Die erweiterte Materialnummer gilt für alle SAP-Länder

20.05 Radiator connection bend RAUTITAN to compact radiators

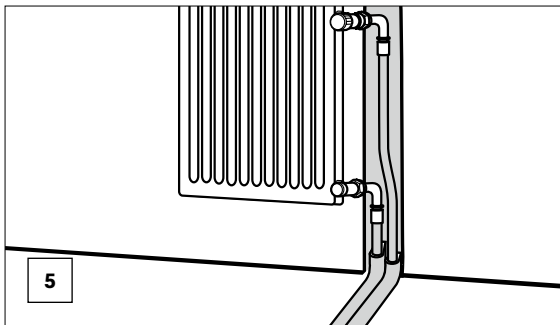

Fig. 20-10



Fig. 20-11

20.06 Direct connection with adapter with male thread RAUTITAN to compact radiators

stabil

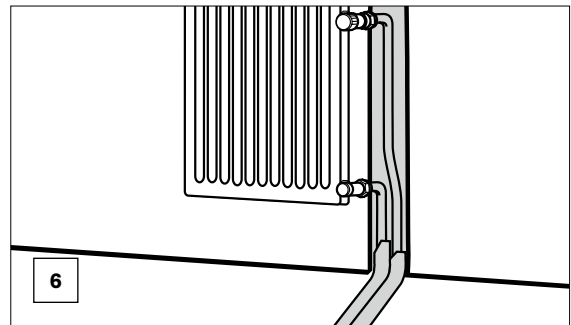

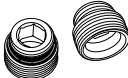

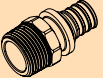
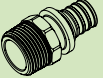

Fig. 20-12



Fig. 20-13

Article	Amount	Article description	Material no.	Article no.
 5	2	Compression sleeve 16 RAUTITAN PX	11600011001	160001-001
 6	or 2	Compression sleeve 20 RAUTITAN PX	11600021001	160002-001
 5	1	Connection nipple set G 1/2 x G 3/4	12407111001	240711-001
 5	2	Screw connection G 3/4 - 15	12406011003	240601-003
 5	2	Radiator connection bend RAUTITAN 16/250	12662421001	266242-001
	or 2	Radiator connection bend RAUTITAN 20/250	12662621001	266262-001
 6	2	Adapter with male thread RAUTITAN RX+ 16 - R 1/2	14563111001	456311-001
	or 2	Adapter with male thread RAUTITAN RX+ 20 - R 1/2	14563141001	456314-001
 6	2	Adapter with male thread RAUTITAN LX 16 - R 1/2	11680851001	168085-001
	or 2	Adapter with male thread RAUTITAN LX 20 - R 1/2	11680901001	168090-001





Tab. 20-4

Achtung: Die erweiterte Materialnummer gilt für alle SAP-Länder

21 Connections with radiator bend

21.01 Connection features

Radiator connections

	Radiator connection bend RAUTITAN	Radiator connection bend sets RAUTITAN		Radiator connection tee RAUTITAN
		Radiator connection bend set	Radiator connection bend set CU/brass	
Connection from	Wall/Floor	Floor	Floor	Floor
Material	Stainless steel	Stainless steel	Copper/Brass	Stainless steel
Expansion of connection pipe with expander head 15 x 1.0	 Essential	 Essential	 Essential	 Essential
Fastening	Fixing unit recommended	Fixing unit recommended	 Fixing unit essential	On site if required
Pipe size	16 and 20 250, 500, 1000 mm	16 and 20 250 mm	16 250 mm	16 and 20 250, 500, 1000 mm

Leg length

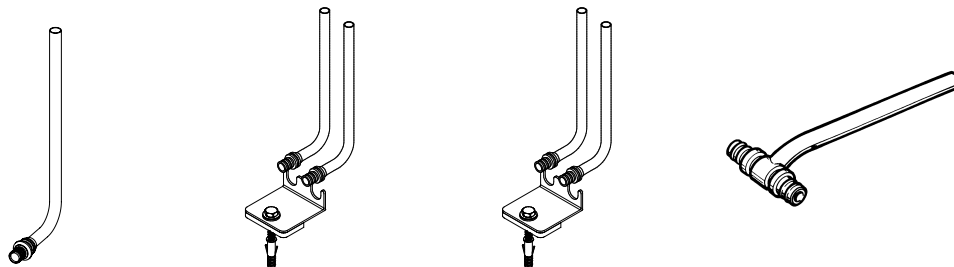

Screw connection G 3/4 - 15

Screw connection

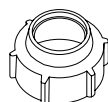

Tab. 21-1 Information on radiator connections



Do not use screw connections in flush-mounted installations or in inaccessible places.

21.02 Screw connections



Fig. 21-1 Screw connection G $\frac{3}{4}$ - 15

- Only for the connection of the radiator connector sets RAUTITAN to male thread G $\frac{3}{4}$ with Eurocone contour according to EN 16313, e.g.:
 - Radiator connection bend RAUTITAN made of stainless steel
 - Radiator connection tee RAUTITAN made of stainless steel
 - Radiator connection bend set CU/brass RAUTITAN
- For pipe size 15 x 1.0 mm
 - Stainless steel connection pipes
 - Copper connection pipes

If the screw connection G $\frac{3}{4}$ - 15 is used, no defined tightening torque is necessary as the screw connection is tightened to the end of the thread.

21.03 Guidelines

Constant temperature fluctuations in the heating systems lead to mechanical loads on the radiator connection bends or tees and their screw connections. If these alternating loads are exerted directly on the radiator connections, this can lead to leaks at the screw connections or damage to the metal radiator sets.

Binding installation instructions

To guarantee a permanently sealed radiator connection, observe the following binding installation specifications:

- Expand the pipe ends of all connection sets using the expander head 15 x 1.0 QC to prevent mechanical effects on the sealing function of these screw connections.
- Fasten the sets with the fixing unit to the floor avoiding alternating loads on the radiator connection bends by thermal length changes in the radiator connecting pipes.
 - The use of the fixing unit is essential for all radiator connection bends made of copper pipe.
 - For radiator connection bends made of stainless steel, the use of the fixing unit is recommended.
- Screw connections must only be detached or tightened once the heating system has cooled.

21.04 Expanding the radiator connection bends or tees RAUTITAN



For soft-sealing screw connections (screw connection G $\frac{3}{4}$ -15) to Eurocone G $\frac{3}{4}$, expand the pipe ends 15 x 1.0 on all radiator connection bends or tees RAUTITAN.



Fig. 21-2 Expander head 15 x 1.0 QC

Steps of work

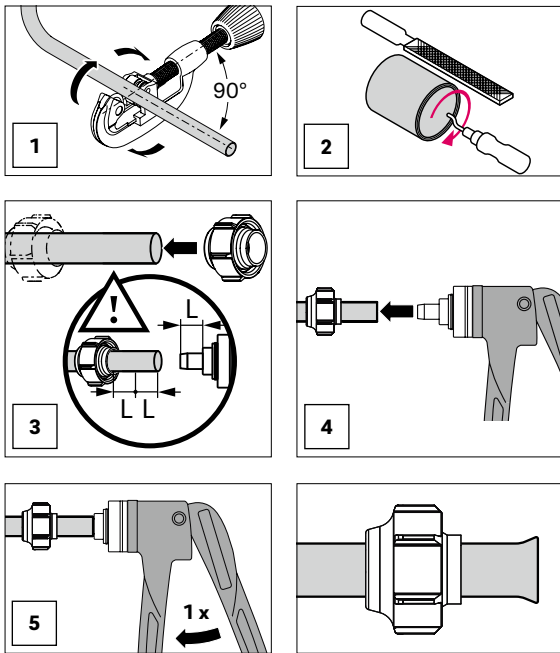

21.05 Fastening radiator connection bends RAUTITAN



Fig. 21-3 Fixing unit

The radiator connection bends are fastened to the unfinished floor with the fixing unit.

- This prevents skewing or slipping of the radiator connection bends
- Prevents inadmissible bending forces, e.g. due to changing temperatures

- Secure and firm fastening suitable for the building site
- Polymer base plate to reduce sound transmission
- Fastening with just one screw
- Including fastening set



Install the radiator connections (e.g. radiator connection bends RAUTITAN and the fixing unit) insulated to the building (thermal and acoustic insulation).

Note the information in the chapter „34 Insulating piping“, page 125 ff.

The use of the fixing unit is also recommended for the radiator connection bends RAUTITAN made of stainless steel to prevent detrimental effects (e. g. skewing when the screed is laid or when the pipes move).

Type of fastening	Connection set	Use of the fixing unit
	Radiator connection bend RAUTITAN made of stainless steel	Recommended
Connection from the floor	Radiator connection tee RAUTITAN made of stainless steel	Not possible, fasten on site if needed
	Radiator connection bend set CU/brass RAUTITAN made of copper	Essential
Connection from the wall	Radiator connection bend set RAUTITAN made of stainless steel	Recommended

Tab. 21-2 Fixation of radiator connections

21.06 Installation procedure for radiator connection bends RAUTITAN – Example

The connection for radiators is described by the example of the radiator connection bend set RAUTITAN in stainless steel:

1. Transfer the leg length including the insertion depth of the Eurocone receiver to the pipe (see Fig. 21-4).
2. Cut the radiator connection bend RAUTITAN square with a roller pipe cutter for stainless steel pipes or a suitable saw and deburr.
3. Push the thermal and acoustic insulation onto the radiator connection bend RAUTITAN (not indicated in the illustrations).
4. Put the screw connection onto the radiator connection bend RAUTITAN.
5. Expand the pipe ends once with the expander head 15 x 1.0 QC (see Fig. 21-5).
6. Insert both radiator connection bend RAUTITAN fully into the fixing unit (see Fig. 21-6).
7. Push the radiator connection bend RAUTITAN fully into the Eurocone of the ball valve block.
8. Tighten the union nuts by hand.
9. Align the radiator connection bend RAUTITAN parallel.
10. Mark the fastening point of the fixing unit (see Fig. 21-7).
11. Detach the radiator connection bend RAUTITAN from the ball valve block.
12. Drill the fastening hole.
13. Fit the radiator connection bend RAUTITAN to the ball valve block.
14. Tighten the union nuts by hand.
15. Screw the fixing unit to the floor with the appropriate fastening set (see Fig. 21-8).
16. Install the soft-sealing screw connections according to the instructions included in the packaging. Tighten the screw connections G ¼ - 15 until they are flush.
17. Create a compression sleeve connection to the heating pipes (see Fig. 21-9).
18. Carry out a leak test.
19. Fully insulate the pipes and connection components.

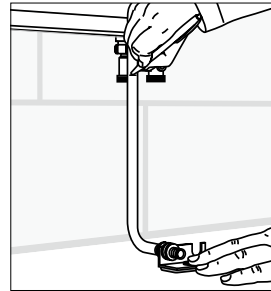

Fig. 21-4 Mark the leg length



Fig. 21-5 Expand one time the pipe end

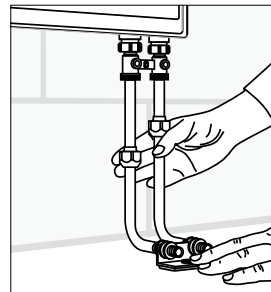

Fig. 21-6 Position the radiator connection bend

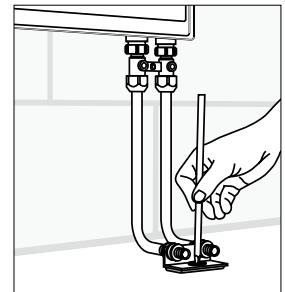

Fig. 21-7 Mark the fastening point

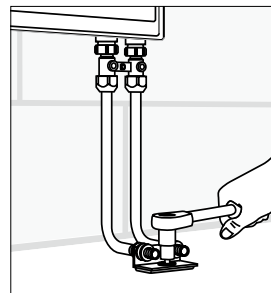

Fig. 21-8 Screw the fixing unit tight

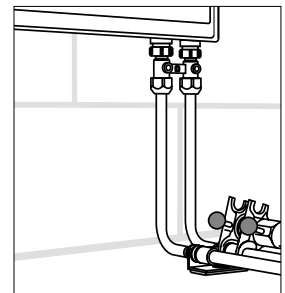

Fig. 21-9 Create compression sleeve connection

22 Connection with manifold union



Fig. 22-1 Manifold union RAUTITAN stabil

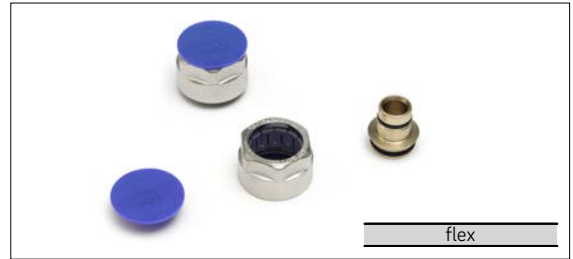

Fig. 22-2 Manifold union RAUTITAN flex

Radiators can be directly connected with the universal pipes RAUTITAN using manifold unions.



Remove from packaging just before using.
Do not store individual parts (union nut, clamping ring, grommet) separately from each other.







Ensure that during assembly and in operation the pipe and the manifold union are free from inadmissible mechanical stress (i.e. due to pipe bend directly after the manifold union).



Connection with union nut should not be installed in-wall or in inaccessible areas.

22.01 Characteristics of the connection process

	Marking union nut	Cap colour	Pipe shears		Pipe calibration	Tightening union nut
Universal pipe RAUTITAN stabil <u>stabil</u>	16.2 x 2.6	Green			 Yes, mandatory 	Up to the stop ¹⁾
	20 x 2.9					Without mechanical stop; tighten at 35 – 45 Nm
Universal pipe RAUTITAN flex <u>flex</u>	16 x 2.2	Blue	Pipe shear 16/20 RAUTITAN 	Pipe shears 25 Pipe shears 40	Not required	Up to the stop ¹⁾
	20 x 2.8					Up to the stop ¹⁾

1) Tighten at max. 35 – 45 Nm

Tab. 22-1 Overview connection with manifold union

22.02 Installation procedure for manifold union RAUTITAN – Example

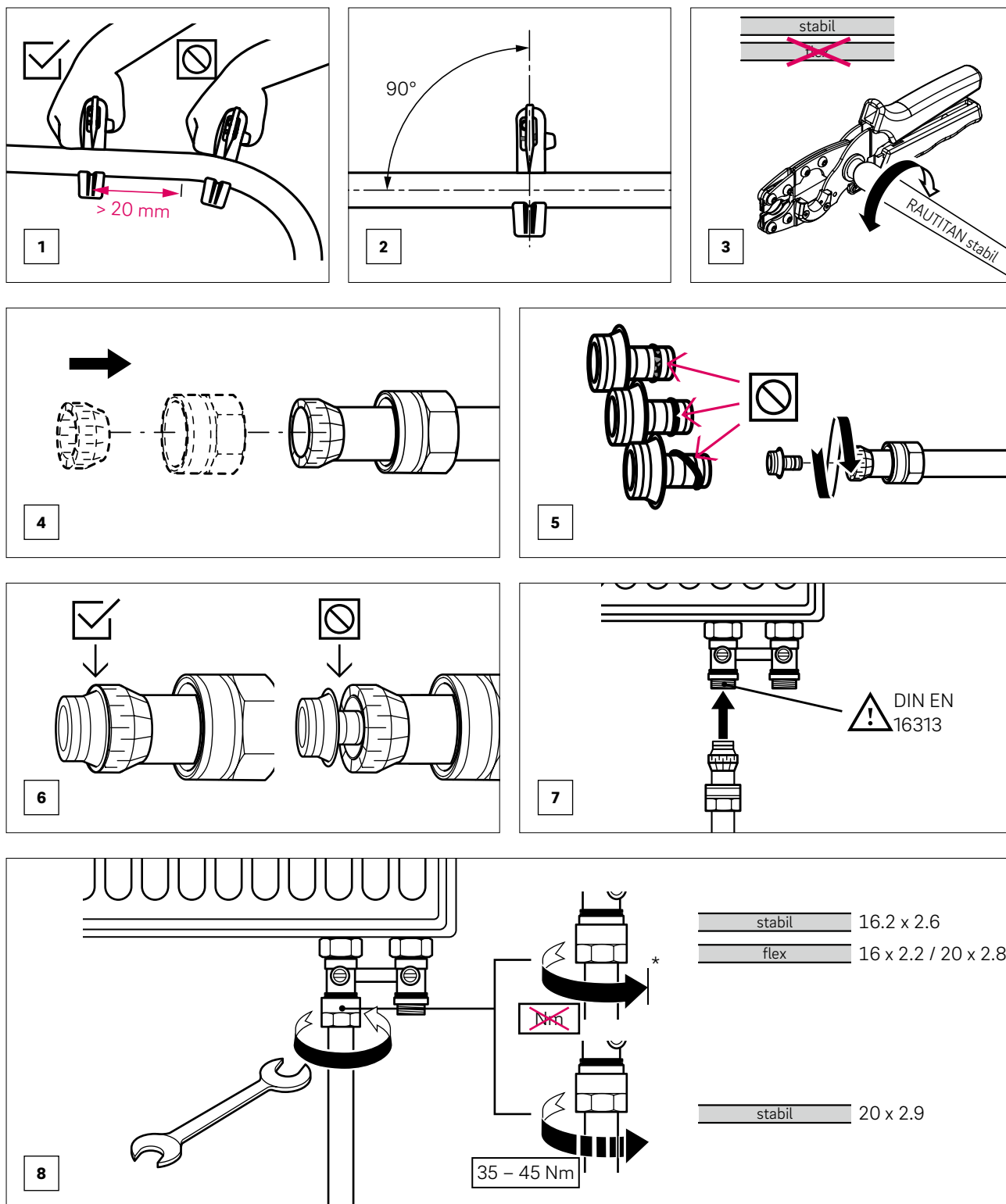

* up to the stop

23 Heating components



- Take specific measures to counter the effects of alternating loads (e.g. expansion bend, additional fastenings or similar).
- Only detach or tighten screw connections once the heating system has cooled.

Eurocone G 3/4

The Eurocone G 3/4 of heating fittings shall fulfil the requirements and measurements of the standard DIN EN 16313.

REHAU recommends:

- Only to use screws, fittings and valves from the same supplier.
- Valve-regulated radiators with connecting female thread Rp 1/2 / G 1/2 to connect the REHAU fittings.

The following screw connections with Eurocone G 3/4 are system tested and can be connected to the ball valve block, connection nipple set G 1/2 x G 3/4, heating pipe manifold and heating circuit manifold:

- Manifold union RAUTITAN stabil
- Manifold union RAUTITAN flex
- Screw connections

23.01 Ball valve block



Fig. 23-1 Ball valve block - angled

Fig. 23-2 Ball valve block - straight

As the shut-off valve and connection between valve-regulated radiators and radiator connecting pipes

- Straight
- Angled
- With connection nipple G 1/2 x G 3/4
- With Eurocone G 3/4



- System-tested screw connection
- Short shape
- For all screw connections and manifold unions with Eurocone G 3/4

23.02 Connection nipple set G 1/2 x G 3/4



Fig. 23-3 Connection nipple set G 1/2 x G 3/4

To connect radiators and valves with female thread Rp 1/2 and screw connections with Eurocone G 3/4

24 Additional system accessories

24.01 Cross fitting RAUTITAN



Fig. 24-1 Cross fitting RAUTITAN with insulating box

The cross fitting RAUTITAN permits a branch in the distribution pipe to the radiator connecting pipe on the floor.

By using the cross fittings RAUTITAN, the screed layer is able to take the insulation directly up to the rectangular insulating box. The cross fitting RAUTITAN can be fastened with the dowel hooks before and after the cross fitting.



- Shortened installation time
- Pipe crosses without chisel work on the rough floor
- Including insulating box
- No additional insulation of the tees
- No bridging of the pipes
- Installation height: 50 mm
- For piping insulation up to an insulation thickness of 13 mm

24.02 Heating pipe manifold stainless steel



Fig. 24-2 Heating pipe manifold

The heating pipe manifold is for distributing and collecting heating water.

For individual designs, different manifold sizes are available for the connection of 2 to 12 radiators. The manifold unions RAUTITAN required for the connections must be ordered separately.

Scope of delivery

- Heating pipe manifold, pressure tested for optional alternate connection
- Connection thread G2, flat sealed
- Connection nipple G 3/4 according to EN 16313 for Eurocone connection
- 2 caps G1
- Bleed valve integrated
- Brackets with acoustic insulation inserts



- Made of high quality stainless steel
- Flat sealed manifold connections
- Two-way manifold connection possible
- Great ease of assembly thanks to staggered placement of connection nipples
- Pre-assembled on brackets with acoustic insulation inserts
- Variable manifold sizes with 2 to 12 outlets

24.03 Double rosette



Fig. 24-3 Double rosette

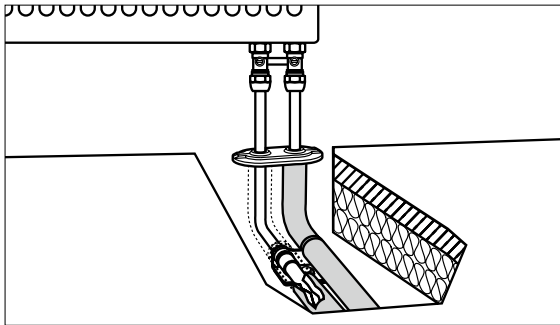

Fig. 24-4 Double rosette on the floor

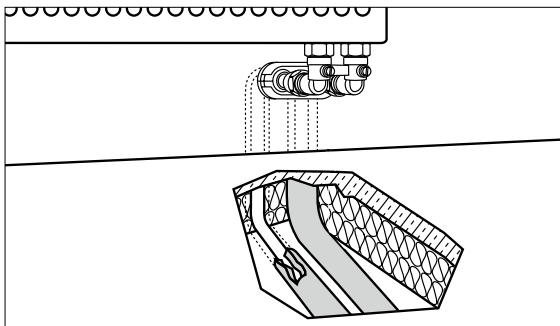

Fig. 24-5 Double rosette on the wall

- To cover radiator connecting pipes in pairs from the wall or the floor
- Two-part
- For pipe size 15
- For the pipe sizes 16 and 20
- Distance between centres: 50 mm
- Colour: White, similar to RAL 9010

24.04 Compression sleeve manifold



Fig. 24-6 Compression sleeve manifold

The compression sleeve manifold can be used as an alternative to the heating pipe manifold.

- Manifold outlets with compression sleeve technique
- Permanently sealed connection
 - Can be installed flush-mounted or under screed
- Compression sleeve with 2 or 3 outlets
 - Can be extended as needed
 - For pipe sizes 16 or 20
- Manifold pipe connections
 - Male thread R $\frac{3}{4}$
 - Female thread Rp $\frac{3}{4}$
- Also suitable for drinking water installation

24.05 Heat meter adapter set

Detailed information about the heat meter adapter set can be found in the Technical Information Underfloor Heating and Cooling.

24.06 Manifold cabinets



Fig. 24-7 Manifold cabinet, flush-mounted version



Fig. 24-8 Manifold cabinet, surface-mounted version

- To receive the heating pipe manifolds and the compression sleeve manifolds
- Available as flush-mounted version (UP) and surface-mounted version (AP)
- Vertically and horizontally adjustable attachment of the manifold bracket
- In sheet steel painted
- For flush-mounted version only:
 - Wall-mounted housing with reinforcement profile and detachable deflector to guide the heating pipes (manifold outlet)
 - Adjustable height
 - Adjustable depth
 - Frame with adjustable depth, with push-fit door and rotary catch

25 Radiator connection from skirting

25.01 Application



Fig. 25-1 Radiator connection from skirting



- Only use the universal pipe RAUTITAN stabil in sizes 16 or 20.
- Use fitting elbow 90° and don't bend the pipe.
- Do not exceed the maximum supply temperature of 70 °C.
- Follow the instruction and specifications from the skirting provider.

25.02 Radiator connection from the skirting

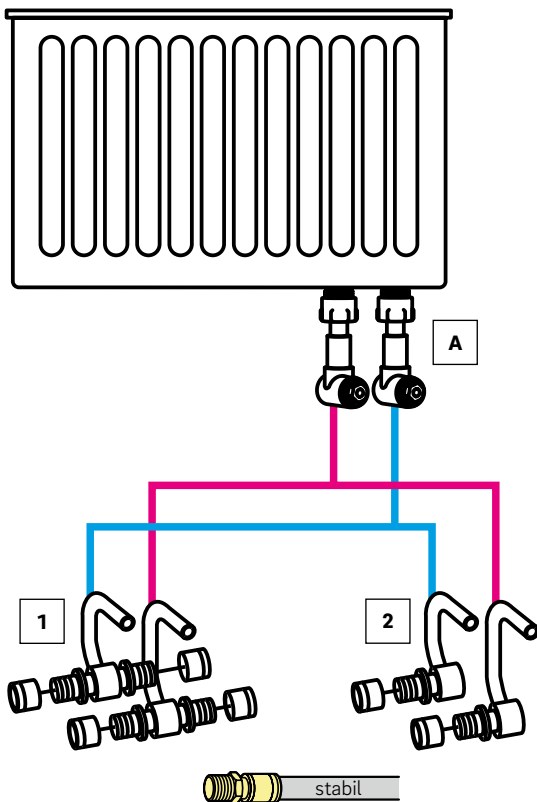

Fig. 25-2 Radiator connection from the skirting

Connection sets to valve-regulated radiator:

- Ⓐ Telescopic corner screw joint set
- 1 Skirting connection set RAUTITAN (see chapter 25.02.01, page 81)
- 2 Skirting end set RAUTITAN (see chapter 25.02.01, page 81)

25.02.01 Skirting connection set RAUTITAN to valve-regulated radiators

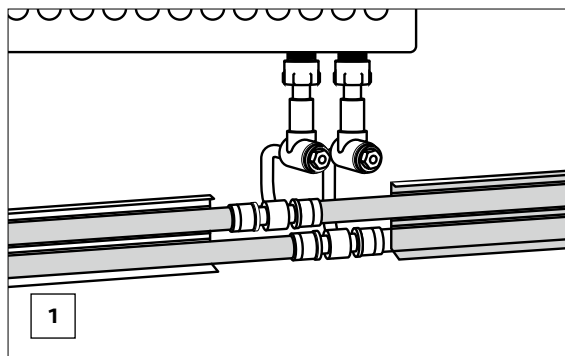

Fig. 25-3



- For the universal pipe RAUTITAN stabil
- For pipe sizes 16 and 20
- Supply and return connections in brass with pre-bent branches in copper pipe 12 x 1.0 mm, nickel plated



- Economical radiator connection version
- Two-part, ready-to-connect unit
- Connection pipes 12 x 1.0 mm integrated into the compression sleeve fittings

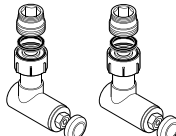
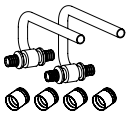

Fig. 25-4

Article	Amount	Article description	Material no.	Article no.
	1	Telescopic corner screw joint set	12406071001	240607-001
	1	Skirting connection set RAUTITAN 16 - 12 - 16	11372381003	137238-003
	or			
	1	Skirting connection set RAUTITAN 20 - 12 - 20	11372391003	137239-003

Tab. 25-1

Achtung: [Die erweiterte Materialnummer gilt für alle SAP-Länder](#)

25.02.02 Skirting end set RAUTITAN to valve-regulated radiators

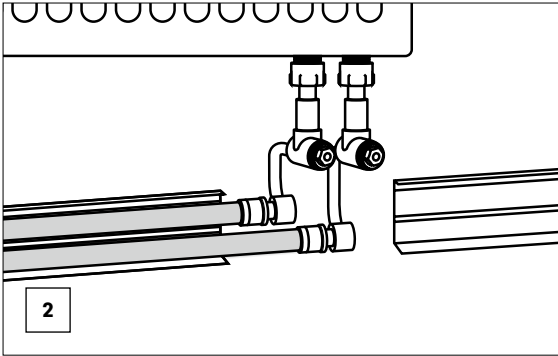

Fig. 25-5

- For the universal pipe RAUTITAN stabil
- For pipe sizes 16 and 20
- Supply and return connections in brass with pre-bent branches in copper pipe 12 x 1.0 mm, nickel plated



- Economical radiator connection version
- Two-part, ready-to-connect unit
- Simple connection of the last radiator
- Connection pipes 12 x 1.0 mm integrated into the compression sleeve fittings

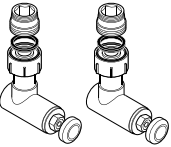
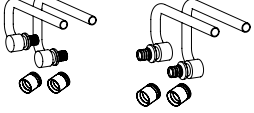
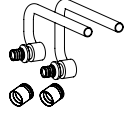

Fig. 25-6

Article	Amount	Article description	Material no.	Article no.
	1	Telescopic corner screw joint set	12406071001	240607-001
	1	Skirting end set RAUTITAN 16 - 12 right	11372471003	137247-003
	1	Skirting end set RAUTITAN 16 - 12 left	11372481003	137248-003
right		left		

Tab. 25-2

Achtung: [Die erweiterte Materialnummer gilt für alle SAP-Länder](#)

25.03 Telescopic corner screw joint set



Fig. 25-7 Telescopic corner screw joint set



Fig. 25-8 Connection of telescopic corner screw joint set

- For connection to valve-regulated radiators with
 - Skirting connection set RAUTITAN
 - Skirting end set RAUTITAN
- With adapter from Eurocone G $\frac{3}{4}$ to flat sealed screw connection G $\frac{3}{4}$
- Radiator connection with telescopically extensible union nut G $\frac{3}{4}$, flat sealing
- Connection to skirting fittings with manifold union to nickel plated copper pipe 12 x 1.0 mm according to DIN EN 1057
- Tension-free and simple installation
- Height (up to 25 mm) and depth adjustment (up to 13 mm)
- Manifold union accessible from the front

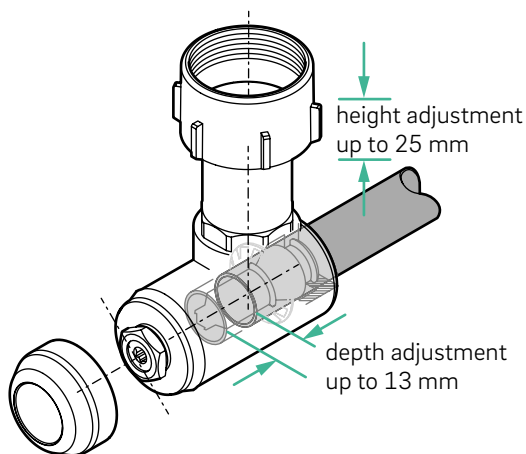

Fig. 25-9 Height and depth adjustment

25.04 Installation of the skirting connection sets RAUTITAN

- Brass connection fitting with pre-bent copper pipes 12 x 1.0 mm
- Two-part
- Nickel plated
- Connection to valve-regulated radiators with telescopic corner screw joint set
- Skirting fittings for both pipe sizes 16 and 20
 - Skirting connection set RAUTITAN 16 - 12 - 16
 - Skirting connection set RAUTITAN 20 - 12 - 20
 - Skirting end set RAUTITAN right 16 - 12
 - Skirting end set RAUTITAN left 16 - 12



- For valve-regulated radiators
- Optionally for left, right or centre connection of valve-regulated radiators
- Connection of radiators with small building depth



Fig. 25-10 Skirting connection set RAUTITAN



Fig. 25-11 Skirting end set RAUTITAN left 16 - 12

Installing a valve-regulated radiator with the skirting fitting RAUTITAN

The assembly instructions apply to:

- RAUTITAN skirting connection sets
 - RAUTITAN skirting end sets
1. Mount the valve-regulated radiator (observe mounting height).
 2. Determine the leg length of the connection pipes 12 x 1.0 mm, saw off and deburr it.
 3. Push for at least 15 mm the telescopic corner screw joint onto the tube of the Skirting connection.
 4. Screw on the union nut of the telescopic corner screw joint set by hand.
 5. Connect the skirting connection set plus compression sleeve technology with the piping.

Connect the telescopic corner screw joint set to the valve-regulated radiator

1. Tighten the union nut firmly at the connection of the valve-regulated radiator with an open-end wrench WS 30.
2. Remove the caps.
3. Tighten the manifold union firmly from the front with an open-end wrench WS 13 (see Fig. 25-12).



Fig. 25-12 Tighten the manifold union firmly

4. Conduct a pressure test.



Shut off or open the telescopic corner fitting:

- Only after fully tightening the integrated compression fitting (SW 13).
- To lock from the front, use a 4 mm Allen key and turn to the right or left.

25.05 General notes on the skirting trunking

Expansion noise

Skirting systems are subject to heavy fluctuations in the temperature during heating phases and thereby are also subject to the corresponding changes in length. Under this influence, small expansion noises can sometimes occur, particularly if the pipes laid, for example, at the wall and ceiling duct area, are under stress.

Corresponding measures must be taken to counter this effect depending on the installation situation on site (e.g. sufficient space for movement of pipes and skirting trunking, pipe insulation in the wall and ceiling breakthroughs).

Installation in radiator niches

When skirting trunking is installed in radiator niches, the minimum distance between two compression sleeve fittings (3 x compression sleeve length) must be observed. The minimum depth of the radiator niche is therefore 130 mm.

26 Pressure Test of heating pipe



The successful execution and documentation of a pressure test is a prerequisite for any warranty claims from the REHAU guarantee and the liability agreement with the German central association for plumbing, heating and air conditioning (ZVSHK).



Deviations to DIN EN 14336 concerning the pressure and tightness test have to be agreed from the building owner and if necessary have to be stipulated by contract.

26.01 Guidelines for pressure test

According to DIN EN 14336 a pressure test must be conducted on the completed but not yet concealed piping before commissioning.

The pressure test result (constant, decreasing, increasing) is generally not enough to completely exclude a leak in the installation.

- The leak-tightness of the system can only be carried out by performing a visual examination of the unconcealed piping.
- Micro leaks can only be located by performing a visual examination (water leakage or leak detection agent) at high pressure.
- Maximum opening pressure of the safety devices shall be considered.

Subdividing the piping system into smaller test sections increases the examination accuracy.



All finished pipe and threaded connections that remain permanently inaccessible or concealed shall be tested during the pressure test.

After the pressure test, only fittings and connection components whose sealing surface is visibly in front of the finished wall (e.g. tiles, plaster) may be connected. These fitting connections must be checked for leaks after commissioning.



- Only use leak detection agents (e.g. foaming agents) with current DVGW registration, which were also approved by the respective manufacturer for the PPSU and PVDF materials.
- When using the cross fitting RAUTITAN the pressure test shall always be performed on both heating circuits simultaneously. A pressure test on each heating circuit separated from each other is not allowed.
The radiator connection block with vent can be used to connect both heating circuits together. The six compression sleeve connectors of the cross fitting RAUTITAN have to be joined to both heating circuits.

Important information on tests with pressurised air and inert gas

- Small leaks can only be detected using leak detection agents at high test pressures or with a supplementary pressure test with water and the appropriate visual inspection.
- Temperature fluctuations can affect the test result (pressure loss or increase).
- Pressurised air and inert gas are compressed gases. This means that the piping volume has a lot of influence on the shown pressure result. A high piping volume reduces the ability to determine small leaks using pressure reduction.

26.02 Purging heating pipes

After the pressure test and shortly before the commissioning the installation should be purge to flush out the dirt from the storage and construction phase.

Recommendations and procedure can be found in the standard DIN EN 14336 considering that chemical cleaning is not recommended.

26.03 Pressure test record: REHAU's RAUTITAN system (heating installation)

The form of pressure test record for a pressure test of a heating installation can be found on the following page.

Pressure test record: REHAU's RAUTITAN system (heating installation)
Form
1. System data

Building project: _____

Client: _____

Address/House No.: _____

Post code/Town/City: _____

Maximum operating pressure: _____

Maximum operating temperature: _____

Geodetic altitude: _____

2. Conduct a pressure test

Conduct a pressure test to verify the sealing of a heating installation with the RAUTITAN system:

1. Dismount safety devices and meters as necessary and replace with pipes or pipe stoppers.
2. Fill the heating installation with filtered water and bleed.
3. Connect the pressure test unit and pressurise the heating installation:
The test pressure must be equivalent to the response pressure of the safety valve. Minimum test pressure: 0.1 MPA / 1 bar
4. After 2 hours, restore the test pressure, as a pressure drop due to expansion of the pipes is possible.
5. Retain the test pressure for at least 3 hours in the heating installation and observe.

6. Also examine the entire heating installation for leaks by a visual inspection:
Water must not escape at any point of the heating installation.
7. If possible, heat the heating installation to the maximum operating temperature after the pressure test, then repeat the visual inspection for leaks.



When screed is laid, the maximum operating pressure must be applied in the heating installation so that leaks can be identified immediately.

3. Confirmed

The leak test was conducted correctly. No leaks were found in the test.

Test pressure: _____ Test duration: _____

Client: _____ Signature: _____

Contractor: _____ Signature: _____

Place: _____ Date: _____

Attachments: _____

27 Pressure loss tables

27.01 Piping network calculation



Various services are offered for the calculation of drinking water and heating systems by REHAU. For extensive advice, please consult your REHAU sales office.

27.02 Overview of the pressure loss tables

Universal pipes RAUTITAN stabil, RAUTITAN flex (spread 1K)	89
Universal pipe RAUTITAN stabil 16	91
Universal pipe RAUTITAN stabil 20	92
Universal pipe RAUTITAN stabil 25	94
Universal pipe RAUTITAN stabil 32	95
Universal pipe RAUTITAN stabil 40	97
Universal pipe RAUTITAN stabil 50	99
Universal pipe RAUTITAN stabil 63	101
Universal pipe RAUTITAN flex 16	103
Universal pipe RAUTITAN flex 20	104
Universal pipe RAUTITAN flex 25	105
Universal pipe RAUTITAN flex 32	106
Universal pipe RAUTITAN flex 40	107

27.03 Notes on using the 1 K-table when calculating the pressure loss

In hot water pump heating systems, the necessary amount of heat for covering heating requirements must be transported via the piping system to the heating areas. The heat emission of the water across the heating area is proportional to the self-adjusting temperature difference (spread) between supply and return connections.

- (1) $\Phi \sim \Delta\theta$
 (2) $\Delta\theta = \theta_V - \theta_R$ [K]

The spread is chosen depending on the heating requirements and the system hydraulics by the planner. Here, the following approximate values are used as a base:

Normal heat requirement Φ [kW]	Spread $\Delta\theta$ [K]
< 50	10 – 20
> 50	≥ 20
Self-contained central heating	~ 10

Tab. 27-1 Spread depending on the heating requirements

During the transfer of heat to the room, the spread influences the flow rate at constant heat output.

$$(3) \quad \Phi = \dot{m} \cdot c \cdot \Delta\theta \text{ [W]}$$

Thus, to the piping network calculation, the flow rate is a relevant size. This size (regardless of the spread) is taken into consideration in the 1 K table.

$$(4) \quad \dot{m} = \frac{\Phi}{c \cdot \Delta\theta} \text{ [kg/h]}$$

With pipe dimensioning, the flow speeds v and the pressure drops R are to be taken into account. Here, the following approximate values should not be exceeded:

- For radiator connecting pipes: $v \sim 0.5$ m/s
 For manifold and rising pipes: $v \sim 1.0 - 1.5$ m/s

- For small systems: $R \sim 100$ Pa/m
 For large systems: $R \sim 100 - 200$ Pa/m



These approximate values are based on empirical values and may differ in individual cases. For example, with short sections in a manifold pipe, the pressure drops R can be set higher.

Example for application with the universal pipe RAUTITAN stabil:

$\Phi = 5815 \text{ W}$ (necessary heat requirements)
 $\Delta\theta = 10 \text{ K}$ (spread)
 $c = 1.163 \text{ Wh/kg}\cdot\text{K}$ (specific thermal capacity of water)

The heating installation pressure loss table (spread 1 K) shows:

- Option 1: RAUTITAN stabil 32 x 4.7
- Option 2: RAUTITAN stabil 25 x 3.7

From (4) we get: $\dot{m} = 500 \text{ kg/h}$

R value Pa/m	RAUTITAN stabil				
	16.2 x 2.6	20 x 2.9	25 x 3.7	32 x 4.7	...
50	53.4	112.3	201.2	396.6	...
	0.16	0.20	0.23	0.28	...
55	56.4	118.6	212.4	418.8	...
	0.17	0.21	0.25	0.29	...
60	59.3	124.7	223.3	440.1	...
	0.18	0.22	0.26	0.31	...
65	62.1	130.5	233.7	460.7	...
	0.19	0.23	0.27	0.32	...
70	64.8	136.2	243.8	480.6	...
	0.20	0.24	0.28	0.34	...
75	67.4	141.6	253.6	500.0	...
	0.21	0.25	0.29	0.35	...
80	69.9	146.9	263.1	518.7	...
	0.22	0.26	0.31	0.37	...
...
220	124.6	261.9	469.1	924.7	...
	0.38	0.47	0.54	0.65	...
240	131.0	275.3	493.0	971.8	...
	0.40	0.49	0.57	0.68	...
260	137.1	288.2	516.0	1017.3	...
	0.42	0.51	0.60	0.72	...
280	143.0	300.6	538.4	1061.3	...
...

Option 1

At 500 kg/h
 Flow speed $v = 0.35 \text{ m/s}$
 Drops in pressure $R = 75 \text{ Pa/m}$

Option 2

Here both values are used in the interpolation:
 At 500 kg/h
 Flow speed $v = 0.58 \text{ m/s}$
 Drops in pressure $R = 245 \text{ Pa/m}$

Tab. 27-2 Metering example

27.04 Pressure loss table: Heating installation (spread 1 K)

Water temperature: 60 °C

R-value Pa/m	RAUTITAN stabil							RAUTITAN flex					m v
	16.2 x 2.6	20 x 2.9	25 x 3.7	32 x 4.7	40 x 6.0	50 x 4.5	63 x 6.0	16 x 2.2	20 x 2.8	25 x 3.5	32 x 4.4	40 x 5.5	
50	53.4	112.3	201.2	396.6	709.4	1994.0	3584.8	66.4	118.9	213.8	430.8	817.3	kg/h
	0.16	0.20	0.23	0.28	0.33	0.43	0.50	0.17	0.20	0.24	0.29	0.34	m/s
55	56.4	118.6	212.4	418.8	749.1	2103.4	3780.0	70.1	125.6	225.8	454.9	863.1	kg/h
	0.17	0.21	0.25	0.29	0.34	0.45	0.52	0.18	0.21	0.25	0.30	0.36	m/s
60	59.3	124.7	223.3	440.1	787.3	2208.2	3967.2	73.7	132.0	237.3	478.1	907.0	kg/h
	0.18	0.22	0.26	0.31	0.36	0.47	0.55	0.19	0.23	0.26	0.32	0.37	m/s
65	62.1	130.5	233.7	460.7	824.1	2309.2	4147.6	77.2	138.1	248.4	500.5	949.5	kg/h
	0.19	0.23	0.27	0.32	0.38	0.49	0.57	0.20	0.24	0.28	0.33	0.39	m/s
70	64.8	136.2	243.8	480.6	859.7	2406.6	4321.6	80.5	144.1	259.1	522.1	990.6	kg/h
	0.20	0.24	0.28	0.34	0.39	0.51	0.60	0.21	0.25	0.29	0.35	0.41	m/s
75	67.4	141.6	253.6	500.0	894.3	2501.0	4490.2	83.7	149.9	269.6	543.1	1030.4	kg/h
	0.21	0.25	0.29	0.35	0.41	0.54	0.62	0.22	0.26	0.30	0.36	0.43	m/s
80	69.9	146.9	263.1	518.7	927.9	2592.4	4653.6	86.9	155.5	279.7	563.5	1069.1	kg/h
	0.22	0.26	0.31	0.37	0.43	0.55	0.64	0.23	0.27	0.31	0.37	0.44	m/s
90	74.8	157.2	281.5	554.9	992.5	2768.0	4967.0	92.9	166.4	299.2	602.7	1143.5	kg/h
	0.23	0.28	0.33	0.39	0.46	0.59	0.69	0.24	0.28	0.33	0.40	0.47	m/s
100	79.4	166.9	298.9	589.3	1054.1	2934.8	5264.8	98.9	176.7	317.7	640.1	1214.5	kg/h
	0.24	0.30	0.35	0.42	0.48	0.63	0.73	0.26	0.30	0.35	0.42	0.50	m/s
110	83.9	176.3	315.7	622.3	1113.1	3094.2	5549.2	104.2	186.6	335.5	676.0	1282.5	kg/h
	0.26	0.31	0.37	0.44	0.51	0.66	0.77	0.27	0.32	0.37	0.45	0.53	m/s
120	88.1	185.3	331.8	654.0	1169.9	3247.2	5822.0	109.5	196.1	352.6	710.4	1347.9	kg/h
	0.27	0.33	0.39	0.46	0.54	0.69	0.81	0.29	0.34	0.39	0.47	0.56	m/s
130	92.3	193.9	347.3	684.6	1224.6	3394.4	6084.6	114.6	205.3	369.1	743.7	1410.9	kg/h
	0.28	0.35	0.40	0.48	0.56	0.73	0.84	0.30	0.35	0.41	0.49	0.58	m/s
140	96.3	202.3	362.3	714.2	1277.6	3536.4	6337.8	119.6	214.1	385.1	775.9	1472.0	kg/h
	0.30	0.36	0.42	0.50	0.59	0.76	0.88	0.31	0.37	0.43	0.51	0.61	m/s
150	100.1	210.5	376.9	742.9	1328.9	3673.8	6583.0	124.4	222.7	400.6	807.1	1531.2	kg/h
	0.31	0.38	0.44	0.52	0.61	0.79	0.91	0.33	0.38	0.44	0.53	0.63	m/s
160	103.9	218.4	391.0	770.8	1378.9	3807.2	6820.6	129.1	231.1	415.6	837.4	1588.7	kg/h
	0.32	0.39	0.45	0.54	0.63	0.81	0.94	0.34	0.40	0.46	0.55	0.66	m/s
170	107.5	226.1	404.8	798.0	1427.5	3936.6	7051.4	133.6	239.3	430.3	866.9	1644.7	kg/h
	0.33	0.40	0.47	0.56	0.65	0.84	0.98	0.35	0.41	0.48	0.57	0.68	m/s
180	111.1	233.6	418.2	824.5	1474.9	4062.8	7276.2	138.1	247.2	444.6	895.7	1699.3	kg/h
	0.34	0.42	0.49	0.58	0.68	0.87	1.01	0.36	0.42	0.49	0.59	0.70	m/s
190	114.6	240.9	431.4	850.4	1521.1	4185.6	7495.0	142.4	255.0	458.5	923.8	1752.6	kg/h
	0.35	0.43	0.50	0.60	0.70	0.90	1.04	0.37	0.44	0.51	0.61	0.72	m/s
200	118.0	248.1	444.2	875.7	1566.4	4305.6	7708.8	146.6	262.5	472.1	951.3	1804.7	kg/h
	0.36	0.44	0.52	0.62	0.72	0.92	1.07	0.39	0.45	0.52	0.63	0.75	m/s
220	124.6	261.9	469.1	924.7	1654.1	4537.4	8121.6	154.9	277.2	498.6	1004.5	1905.8	kg/h
	0.38	0.47	0.54	0.65	0.76	0.97	1.12	0.41	0.47	0.55	0.67	0.79	m/s
240	131.0	275.3	493.0	971.8	1738.4	4759.6	8517.4	162.7	291.4	524.0	1055.7	2002.9	kg/h
	0.40	0.49	0.57	0.68	0.80	1.02	1.18	0.43	0.50	0.58	0.70	0.83	m/s
260	137.1	288.2	516.0	1017.3	1819.7	4973.4	8898.2	170.4	305.0	549.0	1105.1	2096.7	kg/h
	0.42	0.51	0.60	0.72	0.83	1.06	1.23	0.45	0.52	0.61	0.73	0.87	m/s
280	143.0	300.6	538.4	1061.3	1898.5	5179.8	9265.4	177.7	318.2	572.2	1152.1	2187.4	kg/h
	0.44	0.54	0.63	0.75	0.87	1.11	1.28	0.47	0.54	0.64	0.76	0.90	m/s
300	148.8	312.7	560.0	1104.0	1974.8	5379.4	9620.6	184.9	331.0	595.2	1199.3	2275.3	kg/h
	0.46	0.56	0.65	0.78	0.91	1.15	1.33	0.49	0.57	0.66	0.79	0.94	m/s
320	154.4	324.5	581.1	1145.5	2049.0	5572.8	9965.0	191.8	343.4	617.6	1244.3	2360.8	kg/h
	0.48	0.58	0.67	0.81	0.94	1.19	1.38	0.50	0.59	0.69	0.82	0.98	m/s
360	165.1	347.0	621.5	1225.2	2191.6	5943.6	10624.6	205.2	367.3	660.6	1331.0	2525.1	kg/h

R-value Pa/m	RAUTITAN stabil <small>stabil</small>							RAUTITAN flex <small>flex</small>					m v
	16.2 x 2.6	20 x 2.9	25 x 3.7	32 x 4.7	40 x 6.0	50 x 4.5	63 x 6.0	16 x 2.2	20 x 2.8	25 x 3.5	32 x 4.4	40 x 5.5	
	0.51	0.62	0.72	0.86	1.01	1.27	1.47	0.54	0.63	0.73	0.88	1.04	m/s
400	175.4	368.6	660.1	1301.2	2327.6	6295.6	11250.6	217.9	390.1	701.6	1413.6	2681.8	kg/h
	0.54	0.66	0.77	0.92	1.07	1.35	1.56	0.57	0.67	0.78	0.94	1.11	m/s
450	187.6	394.3	706.0	1391.8	2489.7	6713.2	11993.0	233.1	417.3	750.4	1512.0	2868.6	kg/h
	0.58	0.70	0.82	0.98	1.14	1.44	1.66	0.61	0.71	0.83	1.00	1.19	m/s
500	199.2	418.7	749.8	1478.2	2644.2	7109.6	12697.6	247.6	443.2	797.0	1605.8	3046.6	kg/h
	0.61	0.75	0.87	1.04	1.21	1.52	1.76	0.65	0.76	0.88	1.06	1.26	m/s
550	210.4	442.2	791.8	1560.9	2792.2	7487.6	13369.6	261.4	468.0	841.6	1695.7	3217.1	kg/h
	0.65	0.79	0.92	1.10	1.28	1.60	1.85	0.69	0.80	0.93	1.12	1.33	m/s
600	221.1	464.7	832.2	1640.5	2934.5	7487.6	14013.2	274.7	491.8	884.5	1782.1	3381.1	kg/h
	0.68	0.83	0.97	1.16	1.35	1.60	1.94	0.72	0.84	0.98	1.18	1.40	m/s
700	241.4	507.5	908.8	1791.6	3204.8	8534.2	15228.6	300.0	537.1	966.0	1946.2	3692.4	kg/h
	0.74	0.91	1.06	1.26	1.47	1.83	2.11	0.79	0.92	1.07	1.29	1.53	m/s
800	260.6	547.7	980.9	1933.6	3458.9	9173.6	16364.0	323.8	579.7	1042.6	2100.5	3985.2	kg/h
	0.80	0.98	1.14	1.36	1.59	1.96	2.26	0.85	0.99	1.16	1.39	1.65	m/s
1000	296.0	622.2	1114.3	2196.6	3929.3	10347.8	18447.8	367.9	658.6	1184.4	2386.2	4527.2	kg/h
	0.91	1.11	1.29	1.55	1.80	2.21	2.55	0.97	1.13	1.31	1.58	1.87	m/s

Dynamic viscosity: 0.000467 kg/(m·s)

Density: 983.2 kg/m³

27.05 Pressure loss table: Heating installation RAUTITAN stabil 16.2 x 2.6
(spread 10, 15 and 20 K)

stabil

Water temperature: 60 °C

Heat output	Spread 10 K			Spread 15 K			Spread 20 K		
	Flow rate	Speedkeit	Pressure loss	Flow rate	Speedkeit	Pressure loss	Flow rate	Speedkeit	Pressure loss
\dot{Q}	\dot{m}	v	R	\dot{m}	v	R	\dot{m}	v	R
W	kg/h	m/s	Pa/m	kg/h	m/s	Pa/m	kg/h	m/s	Pa/m
400	34.4	0.10	22.1	22.9	0.07	11.2	17.2	0.05	6.9
500	43.0	0.13	32.3	28.7	0.09	16.3	21.5	0.06	10.1
600	51.6	0.15	44.1	34.4	0.10	22.1	25.8	0.08	13.6
700	60.2	0.18	57.5	40.1	0.12	28.8	30.1	0.09	17.7
800	68.8	0.20	72.3	45.9	0.14	36.1	34.4	0.10	22.1
900	77.4	0.23	88.6	51.6	0.15	44.1	38.7	0.12	27.0
1000	86.0	0.26	106.4	57.3	0.17	52.9	43.0	0.13	32.3
1100	94.6	0.28	125.5	63.1	0.19	62.3	47.3	0.14	38.0
1200	103.2	0.31	146.0	68.8	0.20	72.3	51.6	0.15	44.1
1300	111.8	0.33	167.9	74.6	0.22	83.0	55.9	0.17	50.6
1400	120.4	0.36	191.1	80.3	0.24	94.4	60.2	0.18	57.5
1500	129.0	0.38	215.6	86.0	0.26	106.4	64.5	0.19	64.7
1600	137.6	0.41	241.4	91.8	0.27	119.0	68.8	0.20	72.3
1700	146.2	0.43	268.5	97.5	0.29	132.2	73.1	0.22	80.3
1800	154.8	0.46	296.9	103.2	0.31	146.0	77.4	0.23	88.6
1900	163.4	0.49	326.6	109.0	0.32	160.4	81.7	0.24	97.3
2000	172.0	0.51	357.5	114.7	0.34	175.5	86.0	0.26	106.4
2200	189.2	0.56	423.1	126.1	0.38	207.3	94.6	0.28	125.5
2400	206.5	0.61	493.7	137.6	0.41	241.4	103.2	0.31	146.0
2600	223.7	0.66	569.1	149.1	0.44	277.9	111.8	0.33	167.9
2800	240.9	0.72	649.3	160.6	0.48	316.6	120.4	0.36	191.1
3000	258.1	0.77	734.3	172.0	0.51	357.5	129.0	0.38	215.6
3200	275.3	0.82	824.0	183.5	0.55	400.7	137.6	0.41	241.4
3400	292.5	0.87	918.4	195.0	0.58	446.1	146.2	0.43	268.5
3600	309.7	0.92	1017.5	206.5	0.61	493.7	154.8	0.46	296.9
3800	326.9	0.97	1121.2	217.9	0.65	543.4	163.4	0.49	326.6
4000	-	-	-	229.4	0.68	595.3	172.0	0.51	357.5
4200	-	-	-	240.9	0.72	649.3	180.6	0.54	389.7
4400	-	-	-	252.3	0.75	705.4	189.2	0.56	423.1
4500	-	-	-	258.1	0.77	734.3	193.5	0.58	440.3
4700	-	-	-	269.5	0.80	793.6	202.2	0.60	475.6
4900	-	-	-	281.0	0.84	855.0	210.8	0.63	512.1
5100	-	-	-	292.5	0.87	918.4	219.4	0.65	549.8
5300	-	-	-	303.9	0.90	984.0	228.0	0.68	588.7
5500	-	-	-	315.4	0.94	1051.6	236.6	0.70	628.8
5700	-	-	-	326.9	0.97	1121.2	245.2	0.73	670.1
5900	-	-	-	338.4	1.01	1192.9	253.8	0.75	712.6
6100	-	-	-	-	-	-	262.4	0.78	756.3
6300	-	-	-	-	-	-	271.0	0.81	801.1
6500	-	-	-	-	-	-	279.6	0.83	847.2
6700	-	-	-	-	-	-	288.2	0.86	894.4
6900	-	-	-	-	-	-	296.8	0.88	942.8
7100	-	-	-	-	-	-	305.4	0.91	992.3
7300	-	-	-	-	-	-	314.0	0.93	1043.0
7500	-	-	-	-	-	-	322.6	0.96	1094.9
7700	-	-	-	-	-	-	331.2	0.98	1147.9
7900	-	-	-	-	-	-	339.8	1.01	1202.0

Dynamic viscosity: 0.000467 kg/(m·s)

Density: 983.2 kg/m³

27.06 Pressure loss table: Heating installation RAUTITAN stabil 20 x 2.9
(spread 10, 15 and 20 K) stabil

Water temperature: 60 °C

Heat output	Spread 10 K			Spread 15 K			Spread 20 K		
	Flow rate \dot{Q} W	Speed \dot{m} kg/h	Pressure loss v m/s R Pa/m	Flow rate \dot{Q} W	Speed \dot{m} kg/h	Pressure loss v m/s R Pa/m	Flow rate \dot{Q} W	Speed \dot{m} kg/h	Pressure loss v m/s R Pa/m
600	51.6	0.09	13.2	34.4	0.06	6.7	25.8	0.05	4.1
700	60.2	0.11	17.2	40.1	0.07	8.7	30.1	0.05	5.3
800	68.8	0.12	21.6	45.9	0.08	10.8	34.4	0.06	6.7
900	77.4	0.14	26.4	51.6	0.09	13.2	38.7	0.07	8.1
1000	86.0	0.15	31.7	57.3	0.10	15.8	43.0	0.08	9.7
1200	103.2	0.18	43.4	68.8	0.12	21.6	51.6	0.09	13.2
1400	120.4	0.21	56.6	80.3	0.14	28.1	60.2	0.11	17.2
1600	137.6	0.25	71.4	91.8	0.16	35.4	68.8	0.12	21.6
1800	154.8	0.28	87.7	103.2	0.18	43.4	77.4	0.14	26.4
2000	172.0	0.31	105.4	114.7	0.20	52.0	86.0	0.15	31.7
2200	189.2	0.34	124.5	126.2	0.23	61.4	94.6	0.17	37.3
2400	206.5	0.37	145.1	137.6	0.25	71.4	103.2	0.18	43.4
2600	223.7	0.40	167.0	149.1	0.27	82.1	111.8	0.20	49.8
2800	240.9	0.43	190.3	160.6	0.29	93.4	120.4	0.21	56.6
3000	258.1	0.46	214.9	172.0	0.31	105.4	129.0	0.23	63.8
3200	275.3	0.49	240.9	183.5	0.33	118.0	137.6	0.25	71.4
3400	292.5	0.52	268.2	195.0	0.35	131.2	146.2	0.26	79.4
3600	309.7	0.55	296.8	206.5	0.37	145.1	154.8	0.28	87.7
3800	326.9	0.58	326.7	217.9	0.39	159.5	163.4	0.29	96.4
4000	344.1	0.61	358.0	229.4	0.41	174.6	172.0	0.31	105.4
4200	361.3	0.64	390.4	240.9	0.43	190.3	180.6	0.32	114.8
4400	378.5	0.68	424.2	252.3	0.45	206.6	189.2	0.34	124.5
4600	395.7	0.71	459.2	263.8	0.47	223.5	197.8	0.35	134.6
4800	412.9	0.74	495.5	275.3	0.49	240.9	206.5	0.37	145.1
5000	430.1	0.77	533.1	286.7	0.51	259.0	215.1	0.38	155.9
5200	447.3	0.80	571.8	298.2	0.53	277.6	223.7	0.40	167.0
5400	464.5	0.83	611.9	309.7	0.55	296.8	232.3	0.41	178.5
5600	481.7	0.86	653.1	321.1	0.57	316.6	240.9	0.43	190.3
5800	498.9	0.89	695.6	332.6	0.59	337.0	249.5	0.45	202.5
6000	516.1	0.92	739.3	344.1	0.61	358.0	258.1	0.46	214.9
6200	533.3	0.95	784.3	355.6	0.63	379.5	266.7	0.48	227.8
6400	550.5	0.98	830.4	367.0	0.65	401.6	275.3	0.49	240.9
6600	567.7	1.01	877.8	378.5	0.68	424.2	283.9	0.51	254.4
7000	-	-	-	401.4	0.72	471.2	301.1	0.54	282.4
7400	-	-	-	424.4	0.76	520.4	318.3	0.57	311.6
7800	-	-	-	447.3	0.80	571.8	335.5	0.60	342.2
8200	-	-	-	470.3	0.84	625.5	352.7	0.63	374.0
8600	-	-	-	493.2	0.88	681.3	369.9	0.66	407.2
9000	-	-	-	516.1	0.92	739.3	387.1	0.69	441.6
9400	-	-	-	539.1	0.96	799.5	404.3	0.72	477.2
9800	-	-	-	562.0	1.00	861.9	421.5	0.75	514.1
10000	-	-	-	-	-	-	430.1	0.77	533.1
10200	-	-	-	-	-	-	438.7	0.78	552.3
10400	-	-	-	-	-	-	447.3	0.80	571.8
10600	-	-	-	-	-	-	455.9	0.81	591.7
10800	-	-	-	-	-	-	464.5	0.83	611.9
11000	-	-	-	-	-	-	473.1	0.84	632.3
11500	-	-	-	-	-	-	494.6	0.88	684.9

Heat output \dot{Q} W	Spread 10 K			Spread 15 K			Spread 20 K		
	Flow rate \dot{m} kg/h	Speed v m/s	Pressure loss R Pa/m	Flow rate \dot{m} kg/h	Speed v m/s	Pressure loss R Pa/m	Flow rate \dot{m} kg/h	Speed v m/s	Pressure loss R Pa/m
12000	-	-	-	-	-	-	516.1	0.92	739.3
12500	-	-	-	-	-	-	537.6	0.96	795.7
13000	-	-	-	-	-	-	559.1	1.00	854.0

Dynamic viscosity: 0.000467 kg/(m·s)

Density: 983.2 kg/m³

27.07 Pressure loss table: Heating installation RAUTITAN stabil 25 x 3.7
(spread 10, 15 and 20 K) stabil

Water temperature: 60 °C

Heat output	Spread 10 K			Spread 15 K			Spread 20 K		
	Flow rate \dot{Q} W	Speed \dot{m} kg/h	Pressure loss v m/s R Pa/m	Flow rate \dot{Q} W	Speed \dot{m} kg/h	Pressure loss v m/s R Pa/m	Flow rate \dot{Q} W	Speed \dot{m} kg/h	Pressure loss v m/s R Pa/m
1000	86.0	0.10	11.5	57.3	0.07	5.8	43.0	0.05	3.6
1200	103.2	0.12	15.7	68.8	0.08	7.9	51.6	0.06	4.8
1400	120.4	0.14	20.5	80.3	0.09	10.2	60.2	0.07	6.3
1600	137.6	0.16	25.8	91.8	0.11	12.8	68.8	0.08	7.9
2000	172.0	0.20	37.9	114.7	0.13	18.8	86.0	0.10	11.5
2400	206.5	0.24	52.1	137.6	0.16	25.8	103.2	0.12	15.7
2800	240.9	0.28	68.2	160.6	0.19	33.6	120.4	0.14	20.5
3200	275.3	0.32	86.2	183.5	0.21	42.4	137.6	0.16	25.8
3600	309.7	0.36	106.0	206.5	0.24	52.1	154.8	0.18	31.6
4000	344.1	0.40	127.7	229.4	0.27	62.6	172.0	0.20	37.9
4400	378.5	0.44	151.1	252.3	0.29	74.0	189.2	0.22	44.8
4800	412.9	0.48	176.3	275.3	0.32	86.2	206.5	0.24	52.1
5200	447.3	0.52	203.2	298.2	0.35	99.2	223.7	0.26	59.9
5600	481.7	0.56	231.8	321.1	0.37	113.0	240.9	0.28	68.2
6000	516.1	0.60	262.2	344.1	0.40	127.7	258.1	0.30	77.0
6400	550.5	0.64	294.1	367.0	0.43	143.1	275.3	0.32	86.2
6800	584.9	0.68	327.8	390.0	0.45	159.3	292.5	0.34	95.9
7000	602.2	0.70	345.3	401.4	0.47	167.7	301.1	0.35	100.9
7400	636.6	0.74	381.4	424.4	0.49	185.1	318.3	0.37	111.3
7800	671.0	0.78	419.2	447.3	0.52	203.2	335.5	0.39	122.1
8200	705.4	0.82	458.5	470.3	0.55	222.1	352.7	0.41	133.4
8600	739.8	0.86	499.5	493.2	0.57	241.8	369.9	0.43	145.1
9000	774.2	0.90	542.1	516.1	0.60	262.2	387.1	0.45	157.2
9400	808.6	0.94	586.3	539.1	0.63	283.3	404.3	0.47	169.8
9800	843.0	0.98	632.1	562.0	0.65	305.2	421.5	0.49	182.9
10200	877.4	1.02	679.5	584.9	0.68	327.8	438.7	0.51	196.3
10600	-	-	-	607.9	0.71	351.2	455.9	0.53	210.2
11000	-	-	-	630.8	0.73	375.3	473.1	0.55	224.5
11500	-	-	-	659.5	0.77	406.4	494.6	0.57	243.0
12000	-	-	-	688.2	0.80	438.6	516.1	0.60	262.2
12500	-	-	-	716.8	0.83	472.0	537.6	0.62	282.0
13000	-	-	-	745.5	0.87	506.5	559.1	0.65	302.4
13500	-	-	-	774.2	0.90	542.1	580.6	0.67	323.5
14000	-	-	-	802.9	0.93	578.9	602.2	0.70	345.3
14500	-	-	-	831.5	0.97	616.7	623.7	0.72	367.6
15000	-	-	-	860.2	1.00	655.6	645.2	0.75	390.7
15500	-	-	-	-	-	-	666.7	0.77	414.3
16000	-	-	-	-	-	-	688.2	0.80	438.6
16500	-	-	-	-	-	-	709.7	0.82	463.6
17000	-	-	-	-	-	-	731.2	0.85	489.1
17500	-	-	-	-	-	-	752.7	0.87	515.3
18000	-	-	-	-	-	-	774.2	0.90	542.1
18500	-	-	-	-	-	-	795.7	0.92	569.6
19000	-	-	-	-	-	-	817.2	0.95	597.6
19500	-	-	-	-	-	-	838.7	0.97	626.3
20000	-	-	-	-	-	-	860.2	1.00	655.6

Dynamic viscosity: 0.000467 kg/(m·s)

Density: 983.2 kg/m³

27.08 Pressure loss table: Heating installation RAUTITAN stabil 32 x 4.7
(spread 10, 15 and 20 K) stabil

Water temperature: 60 °C

Heat output	Spread 10 K			Spread 15 K			Spread 20 K		
	Flow rate \dot{Q} W	Flow rate \dot{m} kg/h	Speed v m/s	Pressure loss R Pa/m	Flow rate \dot{m} kg/h	Speed v m/s	Pressure loss R Pa/m	Flow rate \dot{m} kg/h	Speed v m/s
1800	154.8	0.11	9.7	103.2	0.07	4.8	77.4	0.05	3.0
2000	172.0	0.12	11.6	114.7	0.08	5.8	86.0	0.06	3.5
2200	189.2	0.13	13.7	126.2	0.09	6.8	94.6	0.07	4.2
2400	206.5	0.15	15.9	137.6	0.10	7.9	103.2	0.07	4.8
2600	223.7	0.16	18.2	149.1	0.11	9.1	111.8	0.08	5.5
2800	240.9	0.17	20.7	160.6	0.11	10.3	120.4	0.08	6.3
3000	258.1	0.18	23.4	172.0	0.12	11.6	129.0	0.09	7.1
3400	292.5	0.21	29.1	195.0	0.14	14.4	146.2	0.10	8.8
3800	326.9	0.23	35.3	217.9	0.15	17.4	163.4	0.12	10.6
4000	344.1	0.24	38.6	229.4	0.16	19.1	172.0	0.12	11.6
4500	387.1	0.27	47.5	258.1	0.18	23.4	193.5	0.14	14.2
5000	430.1	0.30	57.2	286.7	0.20	28.1	215.1	0.15	17.0
5500	473.1	0.33	67.7	315.4	0.22	33.2	236.6	0.17	20.1
6000	516.1	0.36	78.9	344.1	0.24	38.6	258.1	0.18	23.4
6500	559.1	0.39	90.9	372.8	0.26	44.5	279.6	0.20	26.9
7000	602.2	0.42	103.7	401.4	0.28	50.7	301.1	0.21	30.6
7500	645.2	0.45	117.2	430.1	0.30	57.2	322.6	0.23	34.5
8000	688.2	0.48	131.4	458.8	0.32	64.1	344.1	0.24	38.6
8500	731.2	0.51	146.4	487.5	0.34	71.3	365.6	0.26	43.0
9000	774.2	0.55	162.1	516.1	0.36	78.9	387.1	0.27	47.5
9500	817.2	0.58	178.5	544.8	0.38	86.8	408.6	0.29	52.3
10000	860.2	0.61	195.7	573.5	0.40	95.1	430.1	0.30	57.2
10500	903.2	0.64	213.5	602.2	0.42	103.7	451.6	0.32	62.3
11000	946.2	0.67	232.1	630.8	0.44	112.6	473.1	0.33	67.7
11500	989.2	0.70	251.3	659.5	0.46	121.8	494.6	0.35	73.2
12000	1032.3	0.73	271.3	688.2	0.48	131.4	516.1	0.36	78.9
12500	1075.3	0.76	291.9	716.8	0.50	141.3	537.6	0.38	84.8
13000	1118.3	0.79	313.3	745.5	0.53	151.5	559.1	0.39	90.9
13500	1161.3	0.82	335.3	774.2	0.55	162.1	580.6	0.41	97.2
14000	1204.3	0.85	358.0	802.9	0.57	173.0	602.2	0.42	103.7
14500	1247.3	0.88	381.4	831.5	0.59	184.1	623.7	0.44	110.3
15000	1290.3	0.91	405.5	860.2	0.61	195.7	645.2	0.45	117.2
15500	1333.3	0.94	430.2	888.9	0.63	207.5	666.7	0.47	124.2
16000	1376.3	0.97	455.6	917.6	0.65	219.6	688.2	0.48	131.4
16500	1419.4	1.00	481.7	946.2	0.67	232.1	709.7	0.50	138.8
17000	-	-	-	974.9	0.69	244.8	731.2	0.51	146.4
17500	-	-	-	1003.6	0.71	257.9	752.7	0.53	154.1
18000	-	-	-	1032.3	0.73	271.3	774.2	0.55	162.1
18500	-	-	-	1060.9	0.75	285.0	795.7	0.56	170.2
19000	-	-	-	1089.6	0.77	299.0	817.2	0.58	178.5
19500	-	-	-	1118.3	0.79	313.3	838.7	0.59	187.0
20000	-	-	-	1147.0	0.81	327.9	860.2	0.61	195.7
20500	-	-	-	1175.6	0.83	342.8	881.7	0.62	204.5
21000	-	-	-	1204.3	0.85	358.0	903.2	0.64	213.5
21500	-	-	-	1233.0	0.87	373.5	924.7	0.65	222.7
22500	-	-	-	1290.3	0.91	405.5	967.7	0.68	241.6
23500	-	-	-	1347.7	0.95	438.6	1010.8	0.71	261.2

Heat output \dot{Q} W	Spread 10 K			Spread 15 K			Spread 20 K		
	Flow rate \dot{m} kg/h	Speed v m/s	Pressure loss R Pa/m	Flow rate \dot{m} kg/h	Speed v m/s	Pressure loss R Pa/m	Flow rate \dot{m} kg/h	Speed v m/s	Pressure loss R Pa/m
24500	–	–	–	1405.0	0.99	473.0	1053.8	0.74	281.5
25500	–	–	–	1462.4	1.03	508.5	1096.8	0.77	302.5
26500	–	–	–	–	–	–	1139.8	0.80	324.2
27500	–	–	–	–	–	–	1182.8	0.83	346.6
28500	–	–	–	–	–	–	1225.8	0.86	369.6
29500	–	–	–	–	–	–	1268.8	0.89	393.4
30500	–	–	–	–	–	–	1311.8	0.92	417.8
31500	–	–	–	–	–	–	1354.8	0.95	442.9
32500	–	–	–	–	–	–	1397.8	0.98	468.6
33500	–	–	–	–	–	–	1440.9	1.01	495.0

Dynamic viscosity: 0.000467 kg/(m·s)

Density: 983.2 kg/m³

27.09 Pressure loss table: Heating installation RAUTITAN stabil 40 x 6.0
 (spread 10, 15 and 20 K) stabil

Water temperature: 60 °C

Heat output	Spread 10 K			Spread 15 K			Spread 20 K		
	Flow rate \dot{Q} W	Flow rate \dot{m} kg/h	Speed v m/s	Pressure loss R Pa/m	Flow rate \dot{m} kg/h	Speed v m/s	Pressure loss R Pa/m	Flow rate \dot{m} kg/h	Speed v m/s
2800	240.9	0.11	7.5	160.6	0.07	3.7	120.4	0.06	2.3
3000	258.1	0.12	8.5	172.0	0.08	4.2	129.0	0.06	2.6
3200	275.3	0.13	9.5	183.5	0.08	4.7	137.6	0.06	2.9
3400	292.5	0.13	10.5	195.0	0.09	5.2	146.2	0.07	3.2
3600	309.7	0.14	11.6	206.5	0.09	5.8	154.8	0.07	3.5
3800	326.9	0.15	12.7	217.9	0.10	6.3	163.4	0.07	3.9
4000	344.1	0.16	13.9	229.4	0.11	6.9	172.0	0.08	4.2
4500	387.1	0.18	17.1	258.1	0.12	8.5	193.5	0.09	5.1
5000	430.1	0.20	20.6	286.7	0.13	10.2	215.1	0.10	6.2
5500	473.1	0.22	24.3	315.4	0.14	12.0	236.6	0.11	7.3
6000	516.1	0.24	28.3	344.1	0.16	13.9	258.1	0.12	8.5
6500	559.1	0.26	32.6	372.8	0.17	16.0	279.6	0.13	9.7
7000	602.2	0.28	37.2	401.4	0.18	18.2	301.1	0.14	11.0
7500	645.2	0.30	42.0	430.1	0.20	20.6	322.6	0.15	12.5
8000	688.2	0.32	47.0	458.8	0.21	23.0	344.1	0.16	13.9
8500	731.2	0.34	52.3	487.5	0.22	25.6	365.6	0.17	15.5
9000	774.2	0.36	57.9	516.1	0.24	28.3	387.1	0.18	17.1
9500	817.2	0.37	63.8	544.8	0.25	31.1	408.6	0.19	18.8
10000	860.2	0.39	69.8	573.5	0.26	34.1	430.1	0.20	20.6
10500	903.2	0.41	76.1	602.2	0.28	37.2	451.6	0.21	22.4
11000	946.2	0.43	82.7	630.8	0.29	40.3	473.1	0.22	24.3
11500	989.2	0.45	89.5	659.5	0.30	43.6	494.6	0.23	26.3
12000	1032.3	0.47	96.6	688.2	0.32	47.0	516.1	0.24	28.3
13000	1118.3	0.51	111.4	745.5	0.34	54.2	559.1	0.26	32.6
14000	1204.3	0.55	127.2	802.9	0.37	61.8	602.2	0.28	37.2
15000	1290.3	0.59	143.9	860.2	0.39	69.8	645.2	0.30	42.0
16000	1376.3	0.63	161.6	917.6	0.42	78.3	688.2	0.32	47.0
17000	1462.4	0.67	180.2	974.9	0.45	87.2	731.2	0.34	52.3
18000	1548.4	0.71	199.7	1032.3	0.47	96.6	774.2	0.36	57.9
19000	1634.4	0.75	220.6	1089.6	0.50	106.4	817.2	0.37	63.8
20000	1720.4	0.79	241.4	1147.0	0.53	116.6	860.2	0.39	69.8
21000	1806.5	0.83	263.6	1204.3	0.55	127.2	903.2	0.41	76.1
22000	1892.5	0.87	286.7	1261.6	0.58	138.2	946.2	0.43	82.7
23000	1978.5	0.91	310.7	1319.0	0.61	149.7	989.2	0.45	89.5
24000	2064.5	0.95	335.6	1376.3	0.63	161.6	1032.3	0.47	96.6
25000	2150.5	0.99	361.4	1433.7	0.66	173.9	1075.3	0.49	103.9
26000	-	-	-	1491.0	0.68	186.6	1118.3	0.51	111.4
27000	-	-	-	1548.4	0.71	199.7	1163.3	0.53	119.2
28000	-	-	-	1605.7	0.74	213.2	1204.3	0.55	127.2
29000	-	-	-	1663.1	0.76	227.1	1247.3	0.57	135.4
30000	-	-	-	1720.4	0.79	241.4	1290.3	0.59	143.9
31000	-	-	-	1777.8	0.82	256.1	1333.3	0.61	152.6
32000	-	-	-	1835.1	0.84	271.2	1376.3	0.63	161.6
33000	-	-	-	1892.5	0.87	286.7	1419.4	0.65	170.8
34000	-	-	-	1949.8	0.89	302.6	1462.4	0.67	180.2
35000	-	-	-	2007.2	0.92	318.9	1505.4	0.69	189.8
36000	-	-	-	2064.5	0.95	335.6	1548.4	0.71	199.7

Heat output \dot{Q} W	Spread 10 K			Spread 15 K			Spread 20 K		
	Flow rate \dot{m} kg/h	Speed v m/s	Pressure loss R Pa/m	Flow rate \dot{m} kg/h	Speed v m/s	Pressure loss R Pa/m	Flow rate \dot{m} kg/h	Speed v m/s	Pressure loss R Pa/m
37000	-	-	-	2121.9	0.97	352.7	1591.4	0.73	209.8
38000	-	-	-	-	-	-	1633.7	0.75	220.1
40000	-	-	-	-	-	-	1719.7	0.79	241.4
42000	-	-	-	-	-	-	1805.7	0.83	263.6
44000	-	-	-	-	-	-	1891.7	0.87	286.7
46000	-	-	-	-	-	-	1977.6	0.91	310.7
48000	-	-	-	-	-	-	2063.6	0.95	335.6
50000	-	-	-	-	-	-	2149.6	0.99	361.4

Dynamic viscosity: 0.000467 kg/(m·s)

Density: 983.2 kg/m³

27.10 Pressure loss table: Heating installation RAUTITAN stabil 50 x 4.5
(spread 10, 15 and 20 K) stabil

Water temperature: 60 °C

Heat output	Spread 10 K			Spread 15 K			Spread 20 K		
	Flow rate \dot{Q} W	Flow rate \dot{m} kg/h	Speed v m/s	Pressure loss R Pa/m	Flow rate \dot{m} kg/h	Speed v m/s	Pressure loss R Pa/m	Flow rate \dot{m} kg/h	Speed v m/s
4500	387.10	0.08	2.8	258.06	0.06	1.4	193.55	0.04	0.9
5000	430.11	0.09	3.4	286.74	0.06	1.7	215.05	0.05	1.0
5500	473.12	0.10	4.0	315.41	0.07	2.0	236.56	0.05	1.2
6000	516.13	0.11	4.6	344.09	0.07	2.3	258.06	0.06	1.4
6500	559.14	0.12	5.3	372.76	0.08	2.6	279.57	0.06	1.6
7000	602.15	0.13	6.0	401.43	0.09	3.0	301.08	0.06	1.8
7500	645.16	0.14	6.8	430.11	0.09	3.4	322.58	0.07	2.0
8000	688.17	0.15	7.6	458.78	0.10	3.8	344.09	0.07	2.3
8500	731.18	0.16	8.5	487.46	0.10	4.2	365.59	0.08	2.5
9000	774.19	0.17	9.4	516.13	0.11	4.6	387.10	0.08	2.8
9500	817.20	0.17	10.3	544.80	0.12	5.1	408.60	0.09	3.1
10000	860.22	0.18	11.3	573.48	0.12	5.5	430.11	0.09	3.4
11000	946.24	0.20	13.3	630.82	0.13	6.5	473.12	0.10	4.0
12000	1032.26	0.22	15.5	688.17	0.15	7.6	516.13	0.11	4.6
13000	1118.28	0.24	17.9	745.52	0.16	8.8	559.14	0.12	5.3
14000	1204.30	0.26	20.4	802.87	0.17	10.0	602.15	0.13	6.0
16000	1376.34	0.29	25.8	917.56	0.20	12.6	688.17	0.15	7.6
18000	1548.39	0.33	31.8	1032.26	0.22	15.5	774.19	0.17	9.4
20000	1720.43	0.37	38.4	1146.95	0.25	18.7	860.22	0.18	11.3
22000	1892.47	0.40	45.5	1261.65	0.27	22.1	946.24	0.20	13.3
24000	2064.52	0.44	53.2	1376.34	0.29	25.8	1032.26	0.22	15.5
26000	2236.56	0.48	61.4	1491.04	0.32	29.8	1118.28	0.24	17.9
28000	2408.60	0.52	70.1	1605.73	0.34	34.0	1204.30	0.26	20.4
30000	2580.65	0.55	79.3	1720.43	0.37	38.4	1290.32	0.28	23.0
32000	2752.69	0.59	89.1	1835.13	0.39	43.1	1376.34	0.29	25.8
34000	2924.73	0.63	99.4	1949.82	0.42	48.0	1462.37	0.31	28.8
36000	3096.77	0.66	110.2	2064.52	0.44	53.2	1548.39	0.33	31.8
38000	3268.82	0.70	121.5	2179.21	0.47	58.6	1634.41	0.35	35.1
40000	3440.86	0.74	133.2	2293.91	0.49	64.2	1720.43	0.37	38.4
42000	3612.90	0.77	145.5	2408.60	0.52	70.1	1806.45	0.39	41.9
44000	3784.95	0.81	158.3	2523.30	0.54	76.2	1892.47	0.40	45.5
46000	3956.99	0.85	171.6	2637.99	0.56	82.5	1978.49	0.42	49.3
48000	4129.03	0.88	185.4	2752.69	0.59	89.1	2064.52	0.44	53.2
50000	4301.08	0.92	199.6	2867.38	0.61	95.9	2150.54	0.46	57.2
52000	4473.12	0.96	214.4	2982.08	0.64	102.9	2236.56	0.48	61.4
54000	4645.16	0.99	229.6	3096.77	0.66	110.2	2322.58	0.50	65.7
56000	4817.20	1.03	245.3	3211.47	0.69	117.6	2408.60	0.52	70.1
58000	-	-	-	3326.16	0.71	125.3	2494.62	0.53	74.7
60000	-	-	-	3440.86	0.74	133.2	2580.65	0.55	79.3
62000	-	-	-	3555.56	0.76	141.4	2666.67	0.57	84.2
64000	-	-	-	3670.25	0.79	149.7	2752.69	0.59	89.1
66000	-	-	-	3784.95	0.81	158.3	2838.71	0.61	94.2
68000	-	-	-	3899.64	0.83	167.1	2924.73	0.63	99.4
70000	-	-	-	4014.34	0.86	176.1	3010.75	0.64	104.7
71000	-	-	-	4071.68	0.87	180.7	3053.76	0.65	107.4
72000	-	-	-	4129.03	0.88	185.4	3096.77	0.66	110.2
73000	-	-	-	4186.38	0.90	190.1	3139.78	0.67	112.9

Heat output \dot{Q} W	Spread 10 K			Spread 15 K			Spread 20 K		
	Flow rate \dot{m} kg/h	Speed v m/s	Pressure loss R Pa/m	Flow rate \dot{m} kg/h	Speed v m/s	Pressure loss R Pa/m	Flow rate \dot{m} kg/h	Speed v m/s	Pressure loss R Pa/m
74000	-	-	-	4243.73	0.91	194.8	3182.80	0.68	115.7
75000	-	-	-	4301.08	0.92	199.6	3225.81	0.69	118.6
76000	-	-	-	4358.42	0.93	204.5	3268.82	0.70	121.5
77000	-	-	-	4415.77	0.94	209.4	3311.83	0.71	124.4
78000	-	-	-	4473.12	0.96	214.4	3354.84	0.72	127.3
79000	-	-	-	4530.47	0.97	219.4	3397.85	0.73	130.2
80000	-	-	-	4587.81	0.98	224.5	3440.86	0.74	133.2
81000	-	-	-	4645.16	0.99	229.6	3483.87	0.75	136.3
82000	-	-	-	4702.51	1.01	234.8	3526.88	0.75	139.3
83000	-	-	-	-	-	-	3569.89	0.76	142.4
84000	-	-	-	-	-	-	3612.90	0.77	145.5
86000	-	-	-	-	-	-	3698.92	0.79	151.9
88000	-	-	-	-	-	-	3784.95	0.81	158.3
90000	-	-	-	-	-	-	3870.97	0.83	164.9
92000	-	-	-	-	-	-	3956.99	0.85	171.6
94000	-	-	-	-	-	-	4043.01	0.87	178.4
96000	-	-	-	-	-	-	4129.03	0.88	185.4
98000	-	-	-	-	-	-	4215.05	0.90	192.4
100000	-	-	-	-	-	-	4301.08	0.92	199.6
102000	-	-	-	-	-	-	4387.10	0.94	206.9
104000	-	-	-	-	-	-	4473.12	0.96	214.4
106000	-	-	-	-	-	-	4559.14	0.98	221.9
108000	-	-	-	-	-	-	4645.16	0.99	229.6

Dynamic viscosity: 0.000467 kg/(m·s)

Density: 983.2 kg/m³

27.11 Pressure loss table: Heating installation RAUTITAN stabil 63 x 6.0
(spread 10, 15 and 20 K)

stabil

Water temperature: 60 °C

Heat output	Spread 10 K			Spread 15 K			Spread 20 K		
	Flow rate \dot{Q} W	Flow rate \dot{m} kg/h	Speed v m/s	Pressure loss R Pa/m	Flow rate \dot{m} kg/h	Speed v m/s	Pressure loss R Pa/m	Flow rate \dot{m} kg/h	Speed v m/s
4500	387.10	0.05	1.0	258.06	0.04	0.5	193.55	0.03	0.3
5000	430.11	0.06	1.2	286.74	0.04	0.6	215.05	0.03	0.4
5500	473.12	0.07	1.4	315.41	0.04	0.7	236.56	0.03	0.4
6000	516.13	0.07	1.6	344.09	0.05	0.8	258.06	0.04	0.5
6500	559.14	0.08	1.9	372.76	0.05	0.9	279.57	0.04	0.6
7000	602.15	0.08	2.1	401.43	0.06	1.1	301.08	0.04	0.6
7500	645.16	0.09	2.4	430.11	0.06	1.2	322.58	0.04	0.7
8000	688.17	0.10	2.7	458.78	0.06	1.3	344.09	0.05	0.8
8500	731.18	0.10	3.0	487.46	0.07	1.5	365.59	0.05	0.9
9000	774.19	0.11	3.3	516.13	0.07	1.6	387.10	0.05	1.0
9500	817.20	0.11	3.6	544.80	0.08	1.8	408.60	0.06	1.1
10000	860.22	0.12	4.0	573.48	0.08	2.0	430.11	0.06	1.2
11000	946.24	0.13	4.7	630.82	0.09	2.3	473.12	0.07	1.4
12000	1032.26	0.14	5.5	688.17	0.10	2.7	516.13	0.07	1.6
13000	1118.28	0.15	6.3	745.52	0.10	3.1	559.14	0.08	1.9
14000	1204.30	0.17	7.2	802.87	0.11	3.5	602.15	0.08	2.1
16000	1376.34	0.19	9.1	917.56	0.13	4.5	688.17	0.10	2.7
18000	1548.39	0.21	11.2	1032.26	0.14	5.5	774.19	0.11	3.3
20000	1720.43	0.24	13.5	1146.95	0.16	6.6	860.22	0.12	4.0
22000	1892.47	0.26	16.0	1261.65	0.17	7.8	946.24	0.13	4.7
24000	2064.52	0.29	18.7	1376.34	0.19	9.1	1032.26	0.14	5.5
26000	2236.56	0.31	21.5	1491.04	0.21	10.5	1118.28	0.15	6.3
28000	2408.60	0.33	24.5	1605.73	0.22	11.9	1204.30	0.17	7.2
30000	2580.65	0.36	27.8	1720.43	0.24	13.5	1290.32	0.18	8.1
32000	2752.69	0.38	31.1	1835.13	0.25	15.1	1376.34	0.19	9.1
34000	2924.73	0.40	34.7	1949.82	0.27	16.9	1462.37	0.20	10.1
36000	3096.77	0.43	38.5	2064.52	0.29	18.7	1548.39	0.21	11.2
38000	3268.82	0.45	42.4	2179.21	0.30	20.5	1634.41	0.23	12.3
40000	3440.86	0.48	46.5	2293.91	0.32	22.5	1720.43	0.24	13.5
42000	3612.90	0.50	50.7	2408.60	0.33	24.5	1806.45	0.25	14.7
44000	3784.95	0.52	55.1	2523.30	0.35	26.7	1892.47	0.26	16.0
46000	3956.99	0.55	59.7	2637.99	0.36	28.9	1978.49	0.27	17.3
48000	4129.03	0.57	64.5	2752.69	0.38	31.1	2064.52	0.29	18.7
50000	4301.08	0.59	69.4	2867.38	0.40	33.5	2150.54	0.30	20.1
52000	4473.12	0.62	74.5	2982.08	0.41	35.9	2236.56	0.31	21.5
54000	4645.16	0.64	79.7	3096.77	0.43	38.5	2322.58	0.32	23.0
56000	4817.20	0.67	85.2	3211.47	0.44	41.0	2408.60	0.33	24.5
58000	4989.25	0.69	90.7	3326.16	0.46	43.7	2494.62	0.35	26.1
60000	5161.29	0.71	96.5	3440.86	0.48	46.5	2580.65	0.36	27.8
62000	5333.33	0.74	102.4	3555.56	0.49	49.3	2666.67	0.37	29.4
64000	5505.38	0.76	108.4	3670.25	0.51	52.2	2752.69	0.38	31.1
66000	5677.42	0.79	114.6	3784.95	0.52	55.1	2838.71	0.39	32.9
68000	5849.46	0.81	121.0	3899.64	0.54	58.2	2924.73	0.40	34.7
70000	6021.51	0.83	127.6	4014.34	0.56	61.3	3010.75	0.42	36.6
71000	6107.53	0.84	130.9	4071.68	0.56	62.9	3053.76	0.42	37.5
72000	6193.55	0.86	134.3	4129.03	0.57	64.5	3096.77	0.43	38.5
73000	6279.57	0.87	137.7	4186.38	0.58	66.1	3139.78	0.43	39.4

Heat output \dot{Q} W	Spread 10 K			Spread 15 K			Spread 20 K		
	Flow rate \dot{m} kg/h	Speed v m/s	Pressure loss R Pa/m	Flow rate \dot{m} kg/h	Speed v m/s	Pressure loss R Pa/m	Flow rate \dot{m} kg/h	Speed v m/s	Pressure loss R Pa/m
74000	6365.59	0.88	141.1	4243.73	0.59	67.7	3182.80	0.44	40.4
75000	6451.61	0.89	144.6	4301.08	0.59	69.4	3225.81	0.45	41.4
76000	6537.63	0.90	148.1	4358.42	0.60	71.1	3268.82	0.45	42.4
77000	6623.66	0.92	151.7	4415.77	0.61	72.8	3311.83	0.46	43.4
78000	6709.68	0.93	155.3	4473.12	0.62	74.5	3354.84	0.46	44.4
79000	6795.70	0.94	158.9	4530.47	0.63	76.2	3397.85	0.47	45.4
80000	6881.72	0.95	162.6	4587.81	0.63	78.0	3440.86	0.48	46.5
81000	6967.74	0.96	166.3	4645.16	0.64	79.7	3483.87	0.48	47.5
82000	7053.76	0.98	170.1	4702.51	0.65	81.5	3526.88	0.49	48.6
83000	7139.78	0.99	173.9	4759.86	0.66	83.3	3569.89	0.49	49.6
84000	7225.81	1.00	177.7	4817.20	0.67	85.2	3612.90	0.50	50.7
86000	-	-	-	4931.90	0.68	88.9	3698.92	0.51	52.9
88000	-	-	-	5046.59	0.70	92.6	3784.95	0.52	55.1
90000	-	-	-	5161.29	0.71	96.5	3870.97	0.54	57.4
92000	-	-	-	5275.99	0.73	100.4	3956.99	0.55	59.7
94000	-	-	-	5390.68	0.75	104.4	4043.01	0.56	62.1
96000	-	-	-	5505.38	0.76	108.4	4129.03	0.57	64.5
98000	-	-	-	5620.07	0.78	112.6	4215.05	0.58	66.9
100000	-	-	-	5734.77	0.79	116.8	4301.08	0.59	69.4
101000	-	-	-	5792.11	0.80	118.9	4344.09	0.60	70.7
102000	-	-	-	5849.46	0.81	121.0	4387.10	0.61	71.9
104000	-	-	-	5964.16	0.82	125.4	4473.12	0.62	74.5
106000	-	-	-	6078.85	0.84	129.8	4559.14	0.63	77.1
108000	-	-	-	6193.55	0.86	134.3	4645.16	0.64	79.7
110000	-	-	-	6308.24	0.87	138.8	4731.18	0.65	82.4
112000	-	-	-	6422.94	0.89	143.4	4817.20	0.67	85.2
114000	-	-	-	6537.63	0.90	148.1	4903.23	0.68	87.9
116000	-	-	-	6652.33	0.92	152.9	4989.25	0.69	90.7
118000	-	-	-	6767.03	0.94	157.7	5075.27	0.70	93.6
120000	-	-	-	6881.72	0.95	162.6	5161.29	0.71	96.5
122000	-	-	-	6996.42	0.97	167.6	5247.31	0.73	99.4
124000	-	-	-	7111.11	0.98	172.6	5333.33	0.74	102.4
126000	-	-	-	7225.81	1.00	177.7	5419.35	0.75	105.4
127000	-	-	-	-	-	-	5462.37	0.76	106.9
128000	-	-	-	-	-	-	5505.38	0.76	108.4
129000	-	-	-	-	-	-	5548.39	0.77	110.0
130000	-	-	-	-	-	-	5591.40	0.77	111.5
135000	-	-	-	-	-	-	5806.45	0.80	119.4
140000	-	-	-	-	-	-	6021.51	0.83	127.6
150000	-	-	-	-	-	-	6451.61	0.89	144.6
155000	-	-	-	-	-	-	6666.67	0.92	153.5
160000	-	-	-	-	-	-	6881.72	0.95	162.6
165000	-	-	-	-	-	-	7096.77	0.98	172.0
168000	-	-	-	-	-	-	7225.81	1.00	177.7

Dynamic viscosity: 0.000467 kg/(m·s)

Density: 983.2 kg/m³

27.12 Pressure loss table: Heating installation RAUTITAN flex 16 x 2.2
 (spread 10, 15 and 20 K) flex

Water temperature: 60 °C

Heat output	Spread 10 K			Spread 15 K			Spread 20 K		
	Flow rate	Speed	Pressure loss	Flow rate	Speed	Pressure loss	Flow rate	Speed	Pressure loss
\dot{Q}	\dot{m}	v	R	\dot{m}	v	R	\dot{m}	v	R
W	kg/h	m/s	Pa/m	kg/h	m/s	Pa/m	kg/h	m/s	Pa/m
400	34.4	0.09	16.8	22.9	0.06	8.5	17.2	0.05	5.3
500	43.0	0.11	24.5	28.7	0.08	12.3	21.5	0.06	7.6
600	51.6	0.14	33.4	34.4	0.09	16.8	25.8	0.07	10.3
700	60.2	0.16	43.4	40.1	0.11	21.8	30.1	0.08	13.4
800	68.8	0.18	54.6	45.9	0.12	27.3	34.4	0.09	16.8
900	77.4	0.20	66.9	51.6	0.14	33.4	38.7	0.10	20.5
1000	86.0	0.23	80.2	57.3	0.15	39.9	43.0	0.11	24.5
1100	94.6	0.25	94.6	63.1	0.17	47.0	47.3	0.12	28.8
1200	103.2	0.27	110.1	68.8	0.18	54.6	51.6	0.14	33.4
1300	111.8	0.29	126.5	74.5	0.20	62.7	55.9	0.15	38.2
1400	120.4	0.32	143.9	80.3	0.21	71.2	60.2	0.16	43.4
1500	129.0	0.34	162.4	86.0	0.23	80.2	64.5	0.17	48.9
1600	137.6	0.36	181.8	91.7	0.24	89.7	68.8	0.18	54.6
1800	154.8	0.41	223.5	103.2	0.27	110.1	77.4	0.20	66.9
2000	172.0	0.45	268.9	114.7	0.30	132.9	86.0	0.23	80.2
2200	189.2	0.50	318.1	126.1	0.33	156.1	94.6	0.25	94.6
2400	206.4	0.54	371.0	137.6	0.36	181.8	103.2	0.27	110.1
2600	223.6	0.59	427.5	149.1	0.39	209.1	111.8	0.29	126.5
2800	240.8	0.63	487.6	160.5	0.42	238.2	120.4	0.32	143.9
3000	258.0	0.68	551.2	172.0	0.45	268.9	129.0	0.34	162.4
3200	275.2	0.72	618.4	183.5	0.48	301.3	137.6	0.36	181.8
3400	292.4	0.77	689.1	194.9	0.51	335.4	146.2	0.38	202.1
3700	318.2	0.48	801.5	212.1	0.56	389.4	159.1	0.42	234.5
4100	352.6	0.93	963.5	235.1	0.62	467.2	176.3	0.46	280.9
4300	369.8	0.97	1049.5	246.5	0.65	508.4	184.9	0.49	305.5
4500	-	-	-	258.0	0.68	551.2	193.5	0.51	331.0
4700	-	-	-	269.5	0.71	595.6	202.1	0.53	357.4
4900	-	-	-	280.9	0.74	641.6	210.7	0.55	384.8
5100	-	-	-	292.4	0.77	689.1	219.3	0.58	413.1
5300	-	-	-	303.9	0.80	738.1	227.9	0.60	442.2
5500	-	-	-	315.3	0.83	788.6	236.5	0.62	472.2
5700	-	-	-	326.8	0.86	840.7	245.1	0.64	503.2
5900	-	-	-	338.3	0.89	894.3	253.7	0.67	535.0
6100	-	-	-	349.7	0.92	949.4	262.3	0.69	567.7
6300	-	-	-	361.2	0.95	1006.1	270.9	0.71	601.3
6500	-	-	-	372.7	0.98	1064.2	279.5	0.73	635.7
6700	-	-	-	-	-	-	288.1	0.76	671.1
6900	-	-	-	-	-	-	296.7	0.78	707.3
7100	-	-	-	-	-	-	305.3	0.80	744.3
7300	-	-	-	-	-	-	313.9	0.83	782.2
7500	-	-	-	-	-	-	322.5	0.85	821.0
7700	-	-	-	-	-	-	331.1	0.87	860.6
7900	-	-	-	-	-	-	339.7	0.89	901.1
8100	-	-	-	-	-	-	348.3	0.92	942.5
8300	-	-	-	-	-	-	356.9	0.94	984.7
8500	-	-	-	-	-	-	365.5	0.96	1027.7
8800	-	-	-	-	-	-	378.4	0.99	1093.8

Dynamic viscosity: 0.000467 kg/(m·s)

Density: 983.2 kg/m³

27.13 Pressure loss table: Heating installation RAUTITAN flex 20 x 2.8
 (spread 10, 15 and 20 K) flex

Water temperature: 60 °C

Heat output	Spread 10 K			Spread 15 K			Spread 20 K		
	Flow rate \dot{Q} W	Flow rate \dot{m} kg/h	Speed v m/s	Pressure loss R Pa/m	Flow rate \dot{m} kg/h	Speed v m/s	Pressure loss R Pa/m	Flow rate \dot{m} kg/h	Speed v m/s
600	51.6	0.09	12.0	34.4	0.06	6.1	25.8	0.04	3.8
700	60.2	0.10	15.6	40.1	0.07	7.9	30.1	0.05	4.9
800	68.8	0.12	19.6	45.9	0.08	9.9	34.4	0.06	6.1
900	77.4	0.13	24.0	51.6	0.09	12.0	38.7	0.07	7.4
1000	86.0	0.15	28.8	57.3	0.10	14.4	43.0	0.07	8.8
1100	94.6	0.16	33.9	63.1	0.11	16.9	47.3	0.08	10.4
1200	103.2	0.18	39.4	68.8	0.12	19.6	51.6	0.09	12.0
1300	111.8	0.19	45.3	74.5	0.13	22.5	55.9	0.10	13.8
1400	120.4	0.21	51.4	80.3	0.14	25.6	60.2	0.10	15.6
1600	137.6	0.23	64.9	91.7	0.16	32.2	68.8	0.12	19.6
1800	154.8	0.26	79.6	103.2	0.18	39.4	77.4	0.13	24.0
2000	172.0	0.29	95.7	114.7	0.20	47.3	86.0	0.15	28.8
2200	189.2	0.32	113.0	126.1	0.22	55.8	94.6	0.16	33.9
2400	206.4	0.35	131.7	137.6	0.23	64.9	103.2	0.18	39.4
2600	223.6	0.38	151.6	149.1	0.25	74.5	111.8	0.19	45.3
2800	240.8	0.41	172.7	160.5	0.27	84.8	120.4	0.21	51.4
3000	258.0	0.44	195.0	172.0	0.29	95.7	129.0	0.22	58.0
3200	275.2	0.47	218.6	183.5	0.31	107.1	137.6	0.23	64.9
3400	292.4	0.50	243.3	194.9	0.33	119.1	146.2	0.25	72.1
3600	309.6	0.53	269.2	206.4	0.35	131.7	154.8	0.26	79.6
3800	326.8	0.56	296.3	217.9	0.37	144.8	163.4	0.28	87.5
4000	344.0	0.59	324.6	229.3	0.39	158.5	172.0	0.29	95.7
4200	361.2	0.62	354.0	240.8	0.41	172.7	180.6	0.31	104.2
4400	378.4	0.65	384.6	252.3	0.43	187.4	189.2	0.32	113.0
4600	395.6	0.67	416.4	263.7	0.45	202.7	197.8	0.34	122.2
4800	412.8	0.70	449.2	275.2	0.47	218.6	206.4	0.35	131.7
5000	430.0	0.73	483.2	286.7	0.49	234.9	215.0	0.37	141.5
5200	447.2	0.76	518.3	298.1	0.51	251.8	223.6	0.38	151.6
5600	481.6	0.82	591.9	321.1	0.55	287.2	240.8	0.41	172.7
6000	516.0	0.88	670.0	344.0	0.59	324.6	258.0	0.44	195.0
6400	550.4	0.94	752.4	366.9	0.63	364.1	275.2	0.47	218.6
6800	584.8	1.00	839.2	389.9	0.66	405.6	292.4	0.50	243.3
7200	-	-	-	412.8	0.70	449.2	309.6	0.53	269.2
7600	-	-	-	435.7	0.74	494.8	326.8	0.56	296.3
8000	-	-	-	458.7	0.78	542.4	344.0	0.59	324.6
8400	-	-	-	481.6	0.82	591.9	361.2	0.62	354.0
8800	-	-	-	504.5	0.86	643.5	378.4	0.65	384.6
9200	-	-	-	527.5	0.90	697.0	395.6	0.67	416.4
9600	-	-	-	550.4	0.94	752.4	412.8	0.70	449.2
10000	-	-	-	573.3	0.98	809.8	430.0	0.73	483.2
10500	-	-	-	-	-	-	451.5	0.77	527.3
11000	-	-	-	-	-	-	473.0	0.81	573.1
11500	-	-	-	-	-	-	494.5	0.84	620.7
12000	-	-	-	-	-	-	516.0	0.88	670.0
12500	-	-	-	-	-	-	537.5	0.92	721.0
13000	-	-	-	-	-	-	559.0	0.95	773.7
13500	-	-	-	-	-	-	580.5	0.99	828.1

Dynamic viscosity: 0.000467 kg/(m·s)

Density: 983.2 kg/m³

27.14 Pressure loss table: Heating installation RAUTITAN flex 25 x 3.5
 (spread 10, 15 and 20 K) flex

Water temperature: 60 °C

Heat output	Spread 10 K			Spread 15 K			Spread 20 K		
	Flow rate \dot{Q} W	Flow rate \dot{m} kg/h	Speed v m/s	Pressure loss R Pa/m	Flow rate \dot{m} kg/h	Speed v m/s	Pressure loss R Pa/m	Flow rate \dot{m} kg/h	Speed v m/s
1000	86.0	0.09	10.0	57.3	0.06	5.0	43.0	0.05	3.1
1200	103.2	0.11	13.7	68.8	0.08	6.9	51.6	0.06	4.2
1400	120.4	0.13	17.9	80.3	0.09	8.9	60.2	0.07	5.5
1600	137.6	0.15	22.5	91.7	0.10	11.2	68.8	0.08	6.9
1800	154.8	0.17	27.6	103.2	0.11	13.7	77.4	0.08	8.4
2000	172.0	0.19	33.1	114.7	0.13	16.4	86.0	0.09	10.0
2400	206.4	0.23	45.4	137.6	0.15	22.5	103.2	0.11	13.7
2800	240.8	0.26	59.5	160.5	0.18	29.4	120.4	0.13	17.9
3200	275.2	0.30	75.1	183.5	0.20	37.0	137.6	0.15	22.5
3600	309.6	0.34	92.4	206.4	0.23	45.4	154.8	0.17	27.6
4000	344.0	0.38	111.2	229.3	0.25	54.6	172.0	0.19	33.1
4400	378.4	0.41	131.6	252.3	0.28	64.5	189.2	0.21	39.0
4800	412.8	0.45	153.5	275.2	0.30	75.1	206.4	0.23	45.4
5200	447.2	0.49	176.9	298.1	0.33	86.5	223.6	0.24	52.2
5600	481.6	0.53	201.8	321.1	0.35	98.5	240.8	0.26	59.5
6000	516.0	0.56	228.2	344.0	0.38	111.2	258.0	0.28	67.1
6400	550.4	0.60	256.0	366.9	0.40	124.7	275.2	0.30	75.1
6800	584.8	0.64	285.3	389.9	0.43	138.8	292.4	0.32	83.6
7200	619.2	0.68	316.0	412.8	0.45	153.5	309.6	0.34	92.4
7600	653.6	0.71	348.1	435.7	0.48	169.0	326.8	0.36	101.6
8000	688.0	0.75	381.6	458.7	0.50	185.1	344.0	0.38	111.2
8500	731.0	0.80	425.4	487.3	0.53	206.1	365.5	0.40	128.8
9000	774.0	0.84	471.5	516.0	0.56	228.2	387.0	0.42	137.0
9500	817.0	0.89	519.7	544.7	0.59	251.3	408.5	0.45	150.7
10000	860.0	0.94	570.0	573.3	0.63	275.4	430.0	0.47	165.1
10500	903.0	0.99	622.5	602.0	0.66	300.4	451.5	0.49	180.0
11000	-	-	-	630.7	0.69	326.5	473.0	0.52	195.5
11500	-	-	-	659.3	0.72	353.6	494.5	0.54	211.6
12000	-	-	-	688.0	0.75	381.6	516.0	0.56	228.2
12500	-	-	-	716.7	0.78	410.6	537.5	0.59	245.4
13000	-	-	-	745.3	0.81	440.6	559.0	0.61	263.2
13500	-	-	-	774.0	0.84	471.5	580.5	0.63	281.5
14000	-	-	-	802.7	0.88	503.4	602.0	0.66	300.4
14500	-	-	-	831.3	0.91	536.2	623.5	0.68	319.9
15000	-	-	-	860.0	0.94	570.0	645.0	0.70	339.9
15500	-	-	-	888.7	0.97	604.8	666.5	0.73	360.5
16000	-	-	-	917.3	1.00	640.5	688.0	0.75	381.6
16500	-	-	-	-	-	-	709.5	0.77	403.2
17000	-	-	-	-	-	-	731.0	0.80	425.4
17500	-	-	-	-	-	-	752.5	0.82	448.2
18000	-	-	-	-	-	-	774.0	0.84	471.5
18500	-	-	-	-	-	-	795.5	0.87	495.3
19000	-	-	-	-	-	-	817.0	0.89	519.7
19500	-	-	-	-	-	-	838.5	0.92	544.6
20000	-	-	-	-	-	-	860.0	0.94	570.0
20500	-	-	-	-	-	-	881.5	0.96	596.0
21000	-	-	-	-	-	-	903.0	0.99	622.5

Dynamic viscosity: 0.000467 kg/(m·s)

Density: 983.2 kg/m³

27.15 Pressure loss table: Heating installation RAUTITAN flex 32 x 4.4
 (spread 10, 15 and 20 K) flex

Water temperature: 60 °C

Heat output	Spread 10 K			Spread 15 K			Spread 20 K		
	Flow rate \dot{Q} W	Flow rate \dot{m} kg/h	Speed v m/s	Pressure loss R Pa/m	Flow rate \dot{m} kg/h	Speed v m/s	Pressure loss R Pa/m	Flow rate \dot{m} kg/h	Speed v m/s
1800	154.8	0.10	8.3	103.2	0.07	4.1	77.4	0.05	2.5
2000	172.0	0.11	9.9	114.7	0.08	5.0	86.0	0.06	3.0
2200	189.2	0.12	11.7	126.1	0.08	5.8	94.6	0.06	3.6
2400	206.4	0.14	13.6	137.6	0.09	6.8	103.2	0.07	4.1
2600	223.6	0.15	15.6	149.1	0.10	7.8	111.8	0.07	4.7
2800	240.8	0.16	17.8	160.5	0.11	8.8	120.4	0.08	5.4
3000	258.0	0.17	20.0	172.0	0.11	9.9	129.0	0.08	6.1
3400	292.4	0.19	24.9	194.9	0.13	12.3	146.2	0.10	7.5
3800	326.8	0.21	30.3	217.9	0.14	14.9	163.4	0.11	9.1
4200	361.2	0.24	36.1	240.8	0.16	17.8	180.6	0.12	10.8
4600	395.6	0.26	42.3	263.7	0.17	20.8	197.8	0.13	12.6
5000	430.0	0.28	49.0	286.7	0.19	24.1	215.0	0.14	14.6
5500	473.0	0.31	57.9	315.3	0.21	28.4	236.5	0.16	17.2
6000	516.0	0.34	67.5	344.0	0.23	33.1	258.0	0.17	20.0
6500	559.0	0.37	77.8	372.7	0.24	38.1	279.5	0.18	23.0
7000	602.0	0.40	88.7	401.3	0.26	43.4	301.0	0.20	26.2
7500	645.0	0.42	100.2	430.0	0.28	49.0	322.5	0.21	29.6
8000	688.0	0.45	112.4	458.7	0.30	54.9	344.0	0.23	33.1
8500	731.0	0.48	125.2	487.3	0.32	61.0	365.5	0.24	36.8
9000	774.0	0.51	138.6	516.0	0.34	67.5	387.0	0.25	40.7
9500	817.0	0.54	152.6	544.7	0.36	74.3	408.5	0.27	44.7
10000	860.0	0.57	167.2	573.3	0.38	81.3	430.0	0.28	49.0
11000	946.0	0.62	198.3	630.7	0.41	96.3	473.0	0.31	57.9
12000	1032.0	0.68	231.8	688.0	0.45	112.4	516.0	0.34	67.5
13000	1118.0	0.73	267.6	745.3	0.49	129.6	559.0	0.37	77.8
14000	1204.0	0.79	305.8	802.7	0.53	147.9	602.0	0.40	88.7
15000	1290.0	0.85	346.3	860.0	0.57	167.2	645.0	0.42	100.2
16000	1376.0	0.90	389.0	917.3	0.60	187.7	688.0	0.45	112.4
17000	1462.0	0.96	434.1	974.7	0.64	209.2	731.0	0.48	125.2
18000	-	-	-	1032.0	0.68	231.8	774.0	0.51	138.6
19000	-	-	-	1089.3	0.72	255.4	817.0	0.54	152.6
20000	-	-	-	1146.7	0.75	280.1	860.0	0.57	167.2
21000	-	-	-	1204.0	0.79	305.8	903.0	0.59	182.5
22000	-	-	-	1261.3	0.83	332.5	946.0	0.62	198.3
23000	-	-	-	1318.7	0.87	360.3	989.0	0.65	214.8
24000	-	-	-	1376.0	0.90	389.0	1032.0	0.68	231.8
25000	-	-	-	1433.3	0.94	418.8	1075.0	0.71	249.4
26000	-	-	-	1490.7	0.98	449.6	1118.0	0.73	267.6
27000	-	-	-	-	-	-	1161.0	0.76	286.4
28000	-	-	-	-	-	-	1204.0	0.79	305.8
29000	-	-	-	-	-	-	1247.0	0.82	325.7
30000	-	-	-	-	-	-	1290.0	0.85	346.3
31000	-	-	-	-	-	-	1333.0	0.88	367.4
32000	-	-	-	-	-	-	1376.0	0.90	389.0
33000	-	-	-	-	-	-	1419.0	0.93	411.3
34000	-	-	-	-	-	-	1462.0	0.96	434.1
35000	-	-	-	-	-	-	1505.0	0.99	457.5

Dynamic viscosity: 0.000467 kg/(m·s)

Density: 983.2 kg/m³

27.16 Pressure loss table: Heating installation RAUTITAN flex 40 x 5.5
 (spread 10, 15 and 20 K) flex

Water temperature: 60 °C

Heat output	Spread 10 K			Spread 15 K			Spread 20 K		
	Flow rate \dot{Q} W	Flow rate \dot{m} kg/h	Speed v m/s	Pressure loss R Pa/m	Flow rate \dot{m} kg/h	Speed v m/s	Pressure loss R Pa/m	Flow rate \dot{m} kg/h	Speed v m/s
2800	240.8	0.10	6.2	160.5	0.07	3.1	120.4	0.05	1.9
3000	258.0	0.11	7.0	172.0	0.07	3.5	129.0	0.05	2.1
3200	275.2	0.12	7.8	183.5	0.08	3.9	137.6	0.06	2.4
3400	292.4	0.12	8.6	194.9	0.08	4.3	146.2	0.06	2.6
3600	309.6	0.13	9.5	206.4	0.09	4.7	154.8	0.07	2.9
3800	326.8	0.14	10.5	217.9	0.09	5.2	163.4	0.07	3.2
4000	344.0	0.14	11.5	229.3	0.10	5.7	172.0	0.07	3.5
4500	387.0	0.16	14.1	258.0	0.11	7.0	193.5	0.08	4.2
5000	430.0	0.18	16.9	286.7	0.12	8.3	215.0	0.09	5.1
5500	473.0	0.20	20.0	315.3	0.13	9.8	236.5	0.10	6.0
6000	516.0	0.22	23.3	344.0	0.14	11.5	258.0	0.11	7.0
6500	559.0	0.24	26.8	372.7	0.16	13.2	279.5	0.12	8.0
7000	602.0	0.25	30.5	401.3	0.17	15.0	301.0	0.13	9.1
7500	645.0	0.27	34.4	430.0	0.18	16.9	322.5	0.14	10.2
8000	688.0	0.29	38.6	458.7	0.19	18.9	344.0	0.14	11.5
8500	731.0	0.31	42.9	487.3	0.20	21.0	365.5	0.15	12.7
9000	774.0	0.33	47.5	516.0	0.22	23.3	387.0	0.16	14.1
9500	817.0	0.34	52.3	544.7	0.23	25.6	408.5	0.17	15.4
10000	860.0	0.36	57.2	573.3	0.24	28.0	430.0	0.18	16.9
10500	903.0	0.38	62.4	602.0	0.25	30.5	451.5	0.19	18.4
11000	946.0	0.40	67.8	630.7	0.27	33.1	473.0	0.20	20.0
11500	989.0	0.42	73.4	659.3	0.28	35.8	494.5	0.21	21.6
12000	1032.0	0.43	79.1	688.0	0.29	38.6	516.0	0.22	23.3
13000	1118.0	0.47	91.3	745.3	0.31	44.4	559.0	0.24	26.8
14000	1204.0	0.51	104.2	802.7	0.34	50.7	602.0	0.25	30.5
15000	1290.0	0.54	117.9	860.0	0.36	57.2	645.0	0.27	34.4
17000	1462.0	0.61	147.5	974.7	0.41	71.5	731.0	0.31	42.9
19000	1634.0	0.69	180.1	1089.3	0.46	87.1	817.0	0.34	52.3
21000	1806.0	0.76	215.7	1204.0	0.51	104.2	903.0	0.38	62.4
23000	1978.0	0.83	254.1	1318.7	0.55	122.6	989.0	0.42	73.4
25000	2150.0	0.90	295.5	1433.3	0.60	142.3	1075.0	0.45	85.1
27000	2322.0	0.98	339.7	1548.0	0.65	163.4	1161.0	0.49	97.6
28000	-	-	-	1605.3	0.68	174.5	1204.0	0.51	104.2
30000	-	-	-	1720.0	0.72	197.5	1290.0	0.54	117.9
32000	-	-	-	1834.7	0.77	221.9	1376.0	0.58	132.3
34000	-	-	-	1949.3	0.82	247.5	1462.0	0.61	147.5
36000	-	-	-	2064.0	0.87	274.5	1548.0	0.65	163.4
38000	-	-	-	2178.7	0.92	302.7	1634.0	0.69	180.1
40000	-	-	-	2293.3	0.96	332.2	1720.0	0.72	197.5
42000	-	-	-	-	-	-	1806.0	0.76	215.7
44000	-	-	-	-	-	-	1892.0	0.80	234.5
46000	-	-	-	-	-	-	1978.0	0.893	254.1
48000	-	-	-	-	-	-	2064.0	0.87	274.5
50000	-	-	-	-	-	-	2150.0	0.90	295.5
52000	-	-	-	-	-	-	2236.0	0.94	317.3
55000	-	-	-	-	-	-	2365.0	0.99	351.2

Dynamic viscosity: 0.000467 kg/(m·s)

Density: 983.2 kg/m³





Gas system RAUTITAN gas

Contents

28	System components overview	111
29	Area of application	112
29.01	Standards and guidelines	113
29.02	Requirements of the gas	113
30	Assembly components	114
31	Installing RAUTITAN gas pipes	115
31.01	Wall and ceiling ducts	115
31.02	Fire protection	115
31.03	Concealed installation	115
31.04	Piping under screed	116
31.05	Indoor installation	116
31.06	External installation	116
32	Pressure test	118
32.01	Guidelines for pressure test	118
32.02	Pressure test newly installed gas installations	118
32.03	Initial startup	119
32.04	Pressure test record: Gas system RAUTITAN gas from REHAU (gas installation), test according to NEN 1078	119
33	Pressure loss tables	121

28 System components overview

Connection components RAUTITAN gas for gas installation

Size	Pipes	Fittings	Compression sleeves
16	 Gas pipe RAUTITAN gas stabil	 RAUTITAN LX +G	 RAUTITAN PX
20			
25			
32			
40			

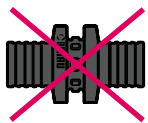

+

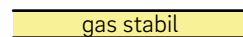

Prohibited use of the fittings RAUTITAN PX in gas installation



+

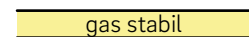

The processing of the gas pipes RAUTITAN gas stabil with the expander head QC 1 is not permitted.

29 Area of application



Validity

This Technical Information is only valid for [country](#).

The gas installation system described in the next pages may only be used in [country](#).

Please observe all safety instructions on page 9, in particular the general safety instructions in relation to gas pipes.



- Only carry out gas installation in buildings with the gas pipes: RAUTITAN gas stabil and fittings RAUTITAN LX +G in combination with the RAUTITAN PX compression sleeve. The fittings RAUTITAN LX +G can be clearly identified by a yellow marking.
- Fittings without this identification/yellow marking may only be used in the drinking water and heating installation.
- Never use RAUTITAN gas items (e.g. gas pipes RAUTITAN gas, fittings RAUTITAN gas) which are marketed by REHAU outside Germany. These have not been approved for use in Germany and cannot be installed.
- Never use the fittings RAUTITAN PX in the gas installation.



Fig. 29-1 RAUTITAN pipe for the gas installation

29.01 Standards and guidelines

§

The gas system RAUTITAN gas must be planned, calculated, executed and operated inside buildings only (from the main shut-off facilities) according to NEN 1078 and the acknowledged technical rules.

RAUTITAN gas pipes are classified as plastic pipes according to ISO 17484-1.

Operating parameters

Continuous operating pressure	Maximum 100 hPa / 100 mbar
Operating temperature	-20 °C to 60 °C
Gas type	2nd and 3rd gas category (natural gas and LPG) according to EN 437

Tab. 29-1 Operating parameters

The following legislation, standards and guidelines have been satisfied by RAUTITAN gas:

KIWA/Gastec product certification

- Yellow gas pipes RAUTITAN gas stabil, the fittings RAUTITAN LX +G with the compression sleeves RAUTITAN PX meet the requirements according to KE 198.
- KIWA/Gastec registration for pipes and jointing techniques (all sizes).

29.02 Requirements of the gas

The RAUTITAN gas system is approved for the conveyance of hot fuel gases according to EN 437.

30 Assembly components

Bracket range



Fig. 30-1 Bracket Z



Fig. 30-2 Bracket E



Fig. 30-3 Bracket 75/150



Fig. 30-4 Installation rail 2 m

Bracket range for elbows RAUTITAN gas and fitting connections

- Rugged and flexible execution
- Galvanised steel
- Easy handling
- Brackets pre-bent in the factory
- For various applications
- Assembly rail as a universal solution for special bracket shapes

Connections in exposed installation with elbows RAUTITAN gas

Elbows RAUTITAN gas for installing onto the bracket range

- In various sizes and lengths
- With different connecting threads
- Each attachable with 45° left or right offset
- Insulating box for RAUTITAN gas Rp ½ elbows

31 Installing RAUTITAN gas pipes

§

Installed surface or covered interior plastic gas piping is not permitted in:

- Escape routes
- Emergency staircases
- Rooms between emergency staircases
- Building exits
- Necessary corridors

31.01 Wall and ceiling ducts

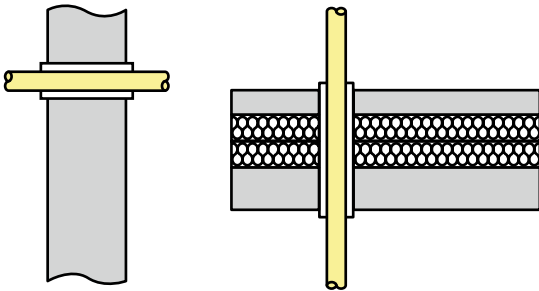

Fig. 31-1 Wall and ceiling ducts with jacket pipes

The RAUTITAN gas pipes can be installed without insulation.

Sometimes the wall ducts and ceiling ducts might incur higher mechanical loads during wall plastering, screed pouring, or carrying out cleaning work, etc. For this reason, we recommend the use of jacket pipes like, for example, the REHAU protective sleeve, REHAU pipe insulation. The jacket pipes should protrude over the wall or ground surface.

For piping through expansion joints, which separate two building parts from each other, make sure that relative movements do not have damaging effects on the piping, e.g. by assembling a stable steel pipe jacket.

31.02 Fire protection

§

If there are fire protection requirements when drilling piping through walls or ceilings, the piping must be fed through approved fire-retarding sealing.

For detailed advice about approved fire-retarding sealing, please consult your REHAU sales office.

31.03 Concealed installation

It is recommended that the laying arrangement be adjusted to the corresponding installation situation and the later usage (e.g. later fastenings for wall cabinets or dividing walls). This should reduce the risk of damaging the piping (e.g. by drilling).

Concealed piping (e.g. behind an exposed/stud wall or flush-mounted) should be installed at right angles.

Flush-mounted piping can be installed without insulation or similar. However, the connection components must be protected against corrosion.

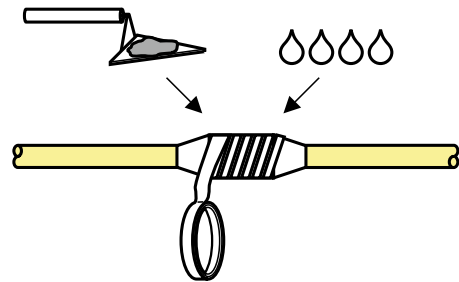

Fig. 31-2 Protect connection components against corrosion

31.04 Piping under screed

Gas piping may not be installed in screed. You may, however, install it under screed in gaps within the rough floor or within a compensating layer under the impact noise insulation on the rough floor..

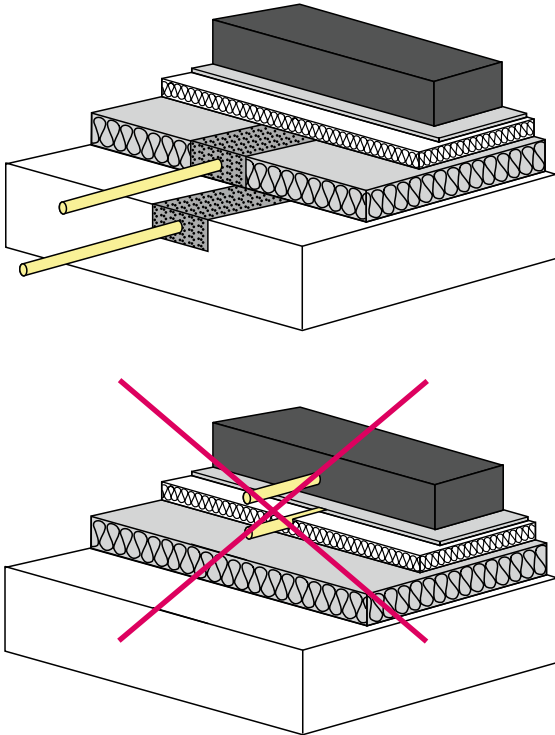

Fig. 31-3 Installation under screed



Should the gas piping be installed in a suitable compensating layer, the increased installation height needs to be taken into account during planning.

It is strongly recommended that the flooring be coordinated with the person laying the screed floor.

§

The RAUTITAN gas system may not be installed under hot asphalt screed, as it cannot be guaranteed that the maximum permitted operating temperature of 60 °C will be maintained.

31.05 Indoor installation



- According to NEN 1078 the laying of gas pipes RAUTITAN gas stabil in front of a window is allowed without protection against UV radiations due to sunlight.
- Against stronger UV-radiations (e.g. due to permanent neon light) the piping has to be protected.
- If the outer layer of the pipe is damaged or if the aluminium layer is visible, the pipe has to be replaced.

31.06 External installation

31.06.01 External installation above ground



Fig. 31-4 Outside laying is not allowed

§

The use of the gas pipe RAUTITAN gas stabil for external installations above ground is not allowed.

31.06.02 External installation below ground

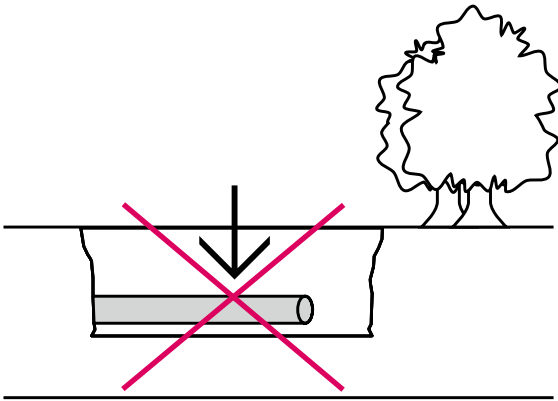

Fig. 31-5 Underground laying is not allowed

§

The use of the gas pipe RAUTITAN gas stabil for external installation below ground is basically not allowed. Exception: Only specific cases which are described in NEN 1078 are allowed.

External installation in-ground (allowed exception)

Concerning the quality of backfill, the cover, laying and installation of external pipings in-ground the requirements according to NEN 1078 shall be followed.



- Protect the piping against damages (e.g. not allowed temperatures, chemicals and mechanical load).
- After the buried RAUTITAN multilayer system has been put into operation, any repair or extension work of the pipe is no longer permitted. In these cases the pipe in ground has to be totally replaced.



During in-ground installation, if the outer PE layer of RAUTITAN multilayer pipe is damaged and the aluminium layer is exposed to the soil, the aluminium layer may corrode with time. The corrosion of aluminium may be visually unpleasant but this does not affect the long term pressure resistance and performance of the RAUTITAN multilayer pipe and is uncritical.

Unlike the gas pipe RAUTITAN gas stabil, which can generally be laying in-ground without protection, the fitting connection must always be protected against corrosion with a **DVGW** approved system.

When using a corrosion protection system, always ensure the following:



- The in-ground connection shall be protected only after the load and leak pressure tests of the installation have been succeeded.
- Confirmation from manufacturer that the corrosion protection system is suitable for the intended application with RAUTITAN gas stabil.
- Follow the instructions of the provider of the corrosion protection.
- In addition to complete coverage of the joint itself, the corrosion protection system has to cover at least 150 mm of the pipe on each side of the connected brass compression sleeve.
- There is no adverse effect on the adhesion of the outer PE-layer to the aluminium layer of the RAUTITAN gas multilayer pipe.
- The system includes an approved cavity filler/ mastic which can be applied to profile the joint, allowing smooth application of the protection tape without any cavities between the tape and fitting.

As corrosion protection we recommend the system Densolen N15/PE5 (Denso GmbH). For detailed advice, please consult your REHAU sales office.



For a rationaler and quicker installation of the pipe in the sizes 20 to 32 we recommend the use of pipe coil without fittings.

32 Pressure test

32.01 Guidelines for pressure test



The successful commissioning and documentation of a pressure test is a prerequisite for any warranty claims to the REHAU guarantee.

Before initial startup of a gas installation, a pressure test for leaks must be carried out in accordance with NEN 1078.

For new construction, the pressure tests need to be carried out before the pipes are plastered or covered.



During the pressure test, only leak detection agents with DVGW registration (DIN EN 14291) may be used. They may temporarily cause hemp packing to swell up thus not indicating leak reliably. In accordance with the requirements of the NEN 1078, the piping needs to be rinsed out with water after completion of the pressure test.

Gas detection devices which comply with DVGW reference note G 465-4 may also be used.

Please note:

- Carry out the pressure test with air (e.g. oil-free pressurised air) or inert gas (e.g. carbon dioxide). Using oxygen is not permitted.
- Small leaks can only be detected using leak detection agents at high test pressures (load test) or with the applicable visual inspection.
- Temperature fluctuations can impair the test result (pressure loss or increase).
- Pressurised air and inert gas are compressed gases. This means that the piping volume has a lot of influence on the shown pressure result. A high piping volume reduces the ability to determine small leaks using pressure reduction.

Statements on the system's leak-tightness derived from the pressure test (constant, decreasing, increasing) can only be asserted in a limited capacity.

- The leak-tightness of the system must always be carried out by performing a visual examination of unconcealed piping.
Micro leaks can only be located by performing a visual examination (leak detection agents) at high pressure.
- Subdivide the piping system into smaller test sections in order to increase the examination accuracy.

32.02 Pressure test newly installed gas installations

Preparing for pressure test

Piping needs to be accessible and cannot be concealed.



The test pressure as well as the pressure progression which occurs during testing does not provide sufficient evidence to the leak-tightness of the system.

For this reason, the entire gas installation must be visually checked for leaks.

1. [Aufeinander folgende Handlungsschritte nach länderspezifischen Anforderungen/Vorgaben beschreiben.](#)
2.



The pressure test can be strongly influenced by the temperature changes and atmospheric pressure fluctuations in the pipe system.

Load test

[National specific requirements](#)

32.03 Initial startup

§

Initial startup of the gas installation must be carried out in accordance with NEN 1078.

Gas must not be allowed to enter leaky piping!

During the initial startup of the gas installations, the composition air-gas mixture will increase.

- Make sure that load and leak tests were carried out before initial startup of the gas installation.
- Seal all pipe stoppers with metal plugs, metal shut-off plates or blind flanges, using safety seal in public space.
Closed fittings are not sufficient as leaktight pipe stoppers.
- Before letting in the gas, make sure that the installation rooms do not contain any dangerous ignitions sources (e.g. do not smoke, switch off mobile phones, switch off electrical systems and fireplaces with naked flames and make sure they cannot switch back on).
- Before initial startup, make sure that the workplace can be left quickly and safely. Keep emergency exits clear.
- Divert the gas/air mix into the fresh air in such a way that it does not pose a danger to anyone.
- Check connections which could not be included in the load and leak tests (e.g. gas appliance connections) for leaks using leak detection agents.

32.04 Pressure test record: Gas system RAUTITAN gas from REHAU (gas installation), test according to NEN 1078

The form of a pressure test record for a pressure test of a gas installation can be found on the following page.

This test record has to be adapted according the requirements that apply in each country.

Pressure test record: Gas system: RAUTITAN gas from REHAU (gas installation), test according to DVGW-TRGI 2008

Form

1. System data

Building project: _____ Client: _____
 Address/House No.: _____ Post code/Town/City: _____
 Client represented by: _____ Contractor represented by: _____

Maximum operating pressure: _____ hPa (≤ 100 hPa / 100 mbar (low pressure))
 The gas piping was examined: as total piping in _____ sections
 Test media: Air Nitrogen _____
 All pipes are sealed with metal plugs, caps, shut-off plates or blind flanges.

2. Load test

2.1 Fittings removed
 installed (nominal pressure \geq test pressure)
 2.2 Test pressure _____ (0.1 MPa / 1 bar)
 2.3 Testing time: 10 minutes
 Current test pressure _____ (0.1 MPa / 1 bar)
 2.4 Test pressure did not drop during the testing period.
 2.5 Entire gas installation, particularly the joints, checked visually and with leak detection agents for leak-tightness.
 No leaks were found during the visual check.
 Determined pipe volume _____ (l)

Size	Content
RAUTITAN gas stabil	[l/m]
20	0.158
25	0.243
32	0.401
40	0.616

Table for determining the pipe volume

3. Leak test

3.1 The fittings are installed.
 3.2 Test pressure _____ (150 hPa / 150 mbar)
 Adaptation time _____ (min)
 Test pressure after adaptation time _____ (150 hPa / 150 mbar)
 Test duration _____ (min)
 Test pressure after test duration _____ (150 hPa / 150 mbar)
 Joints which were not examined during the load test were checked visually with leak detection agents.
 3.3 Test pressure did not drop during the testing period.
 3.4 The system is leak-tight.

Piping volume	Adaption time ¹⁾	Minimum test duration ¹⁾
< 100 l	10 min	10 min
$\geq 100 < 200$ l	30 min	20 min
≥ 200 l	60 min	30 min

1) Approximate values

4. Confirmed

Company stamp / Signature of the tester: _____

Town/City: _____ Date: _____

Attachments: _____

33 Pressure loss tables

Länderspezifische Anforderungen/Vorgaben

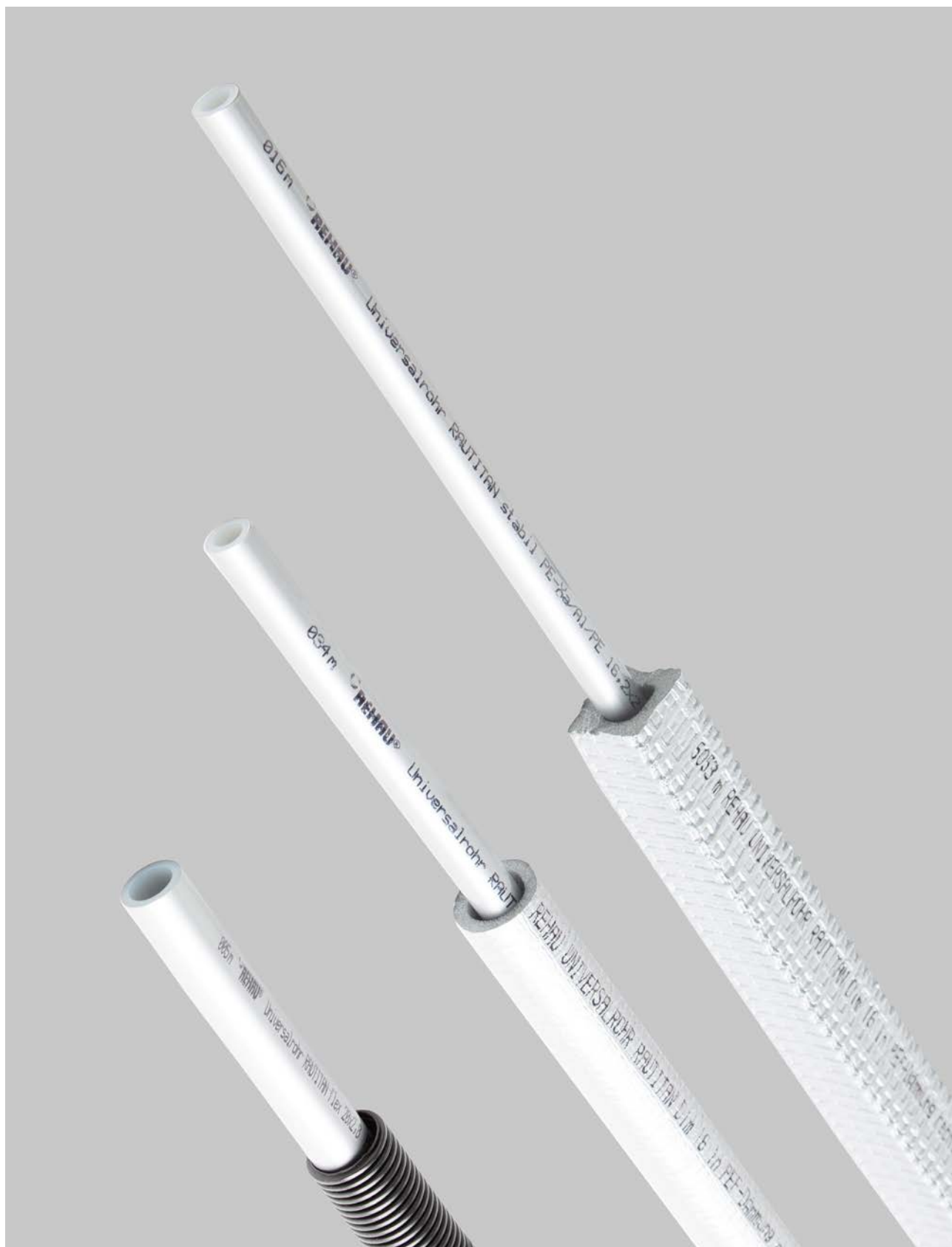

Insulation and noise protection

Contents

34	Insulating piping	125
34.01	General tasks of pipe insulations	125
34.02	Pipe insulation	125
34.03	Fitting insulation	125
34.04	Benefits of using factory-manufactured pre-insulated pipes	125
34.05	Standard and guidelines	126
34.06	Insulation of drinking water piping according to DIN 1988-200 and GEG	126
34.07	Insulation of heating piping according to German Building Energy Law (GEG)	128
34.08	Pre-insulated pipes - Applications	130
35	Noise protection	132
35.01	Preventative measures to reduce the creation of sound	132
35.02	Benefits of using the universal system RAUTITAN for drinking water and heating	132
35.03	Noise insulating properties of the piping	133

34 Insulating piping

The specifications in this chapter only apply to

stabil	Universal pipe RAUTITAN stabil
flex	Universal pipe RAUTITAN flex

34.01 General tasks of pipe insulations

Pipe insulation can be thermal insulation or any other kind of pipe cladding:

- Reduces heating of cold water pipes
- Protection against condensation
- Reduction of heat loss
- Restriction of heat emission from hot piping
- Reduction of sound transmission (separation of the piping from the building)
- Protection of piping against UV radiation
- Allow small amount of thermal movement within the insulation sleeve
- Mechanical protection against damage
- Corrosion protection of the piping

Consult the client and the contractors of other trades on the intended type and thickness of the insulation before beginning work.



Always insulate/clad pipes and connection components, even though thermal insulation is not mandatory.

34.02 Pipe insulation

REHAU pipes are factory pre-insulated in various types:

- Available for several pipe sizes
- In various insulation strengths according to DIN EN 806, DIN 1988 and GEG
- With insulation Building material class B2 acc. DIN 4102-1 or Construction product class E acc. DIN EN 13501-1, in closed-cell PE foam with co-extruded PE film moisture barrier
 - In round shape
 - In eccentric shape
- Fed into protective PE piping at the factory
- Proof of equivalence for insulation with eccentric room shape (test report with calculation of equivalent heat output to concentric insulation with thermal conductivity group WLG 040, Fraunhofer Institute for Building Physics IBP, Stuttgart)
- The technical properties of the insulation are specified in accordance with DIN EN 14313 (Thermal insulation materials for building services and indus-

trial installations - Factory-made polyethylene foam (PEF) products).

Unlike pipe insulation alone, factory-preinsulated pipes are not permitted to bear a CE marking because they are marketed as a combined, uniform product (pipe with insulation) and there is no harmonized product standard for these products. Therefore, due to the non-existence of a CE marking, no DoP (Declaration of Performance) can be issued for these products.



Insulation thicknesses which are not within the REHAU product range, must be carried out on site. In the case of long-term stagnation, the insulation is not a permanent protection against heating or cooling.

34.03 Fitting insulation

As a supplement to the on-site insulation of fittings, REHAU provides the following easily-installed insulating boxes:

- Insulating box for elbows Rp ½
- Cross fitting RAUTITAN with insulating box

34.04 Benefits of using factory-manufactured pre-insulated pipes



Fig. 34-1 Pre-insulated pipe RAUTITAN



- Fewer points (insulation joints) which must be isolated later
- Efficient and fast pipe laying
- For insulation with eccentric shapes, no additional laying of a compensating layer necessary as specified in DIN 18560-2 (test certificate for impact sound reduction of a floating screed with inserted, water-filled, insulated pipes, Fraunhofer Institute for Building Physics IBP, Stuttgart)
- Lower storage and transport costs

34.05 Standard and guidelines

When insulating pipes, observe the following statutory regulations and standards:

- Drinking water pipes
 - DIN EN 806
 - DIN 1988 (cold and hot)
 - German Building Energy Law (GEG) (hot drinking water)
 - Country-specific standards and guidelines
- Heating pipes
 - German Building Energy Law (GEG)
 - Country specific standards and guidelines

34.06 Insulation of drinking water piping according to DIN 1988-200 and GEG

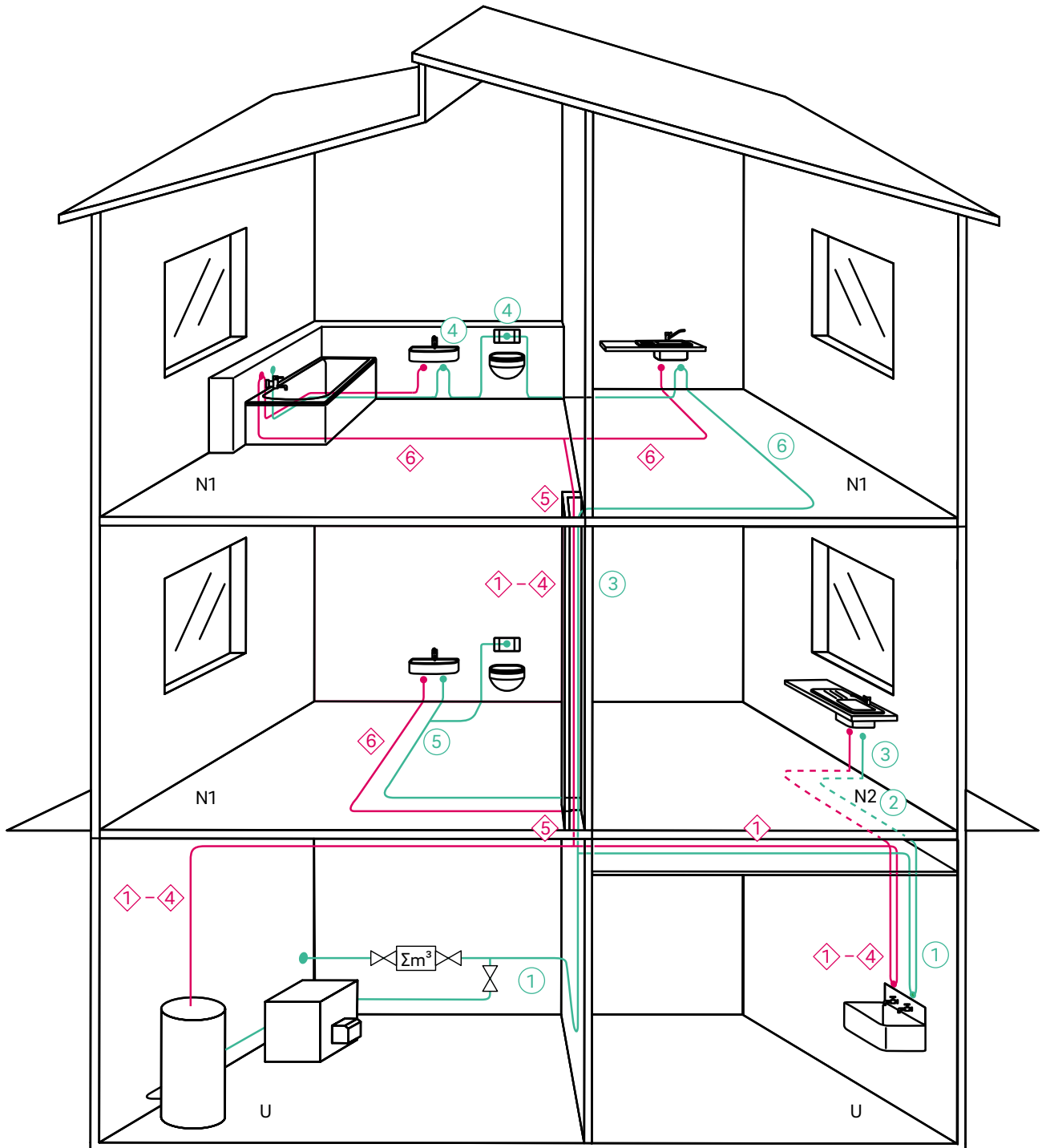









Fig. 34-2 Installation situations of piping insulation





N1 User 1 N2 User 2 U Unheated

Recommended values of thickness for the insulation of cold drinking water pipes according to DIN 1988-200

No.	Installation conditions	Minimum thickness of round shape insulations with $\lambda = 0.04 \text{ W}/(\text{m} \cdot \text{K})^1$	pre-insulated in size 16 – 25	
			stabil flex	
①	Above-ground pipes in unheated rooms, ambient temperature $< 20 \text{ }^\circ\text{C}$, only to prevent condensation on pipes	9 mm		9 mm
②	Pipes in ducts, shafts and suspended ceilings, ambient temperature $\leq 25 \text{ }^\circ\text{C}$	13 mm		13 mm
③	Above-ground or concealed pipes and exposed to thermal loads, ambient temperature $> 25 \text{ }^\circ\text{C}$	Same insulation as hot water pipes		
④	Floor distribution branches and single supply pipes behind exposed installation ²⁾	4 mm or in protective pipe		
⑤	Floor distribution branches and single supply pipes within a floor construction without adjacent circulating hot water pipes ³⁾	4 mm or in protective pipe		
⑥	Floor distribution branches and single supply pipes within a floor construction with adjacent circulating hot water pipes ³⁾	13 mm		13 mm

Tab. 34-1 Recommended values of thickness for the insulation of cold drinking water pipes according to DIN 1988-200

Recommended values of thickness for the insulation of warm and circulation drinking water pipes according to DIN 1988-200 and GEG

No.	Installation conditions	Minimum thickness of round shape insulations with $\lambda = 0.035 \text{ W}/(\text{m} \cdot \text{K})^1$	pre-insulated in size 16 – 25	
			stabil flex	
①	Inner pipe diameter $< 22 \text{ mm}$	20 mm		26 mm $\lambda = 0.04 \text{ W}/(\text{m} \cdot \text{K})$
②	Inner pipe diameter $22 - 35 \text{ mm}$	30 mm		on site
③	Inner pipe diameter $35 - 100 \text{ mm}$	Same as inner pipe diameter		on site
④	Inner pipe diameter $> 100 \text{ mm}$	100 mm		on site
⑤	Pipes and fittings <ul style="list-style-type: none"> in wall and ceiling penetrations or in cross-overs or at pipe joints or at central pipe network manifolds 	50 % of the requirements of lines 1 – 4 according to pipe diameter		13 mm $\lambda = 0.04 \text{ W}/(\text{m} \cdot \text{K})$ Size 25 on site
⑥	Non-circulating hot drinking water pipes which apply the following requirements: <ul style="list-style-type: none"> a water content $\leq 3 \text{ l}$ and not included in the circulation system or equipped with auxiliary electric heating and pipes to a single draw-off point which are layed in a heated room ⁴⁾ 	No requirements  Insulation must nevertheless be implemented for the following reasons: <ul style="list-style-type: none"> Reduction of heat loss Sound insulation Protection of the piping etc. 		4 mm $\lambda = 0.04 \text{ W}/(\text{m} \cdot \text{K})$ 
⑦	Piping, which borders on outside air grenzen ⁴⁾ (not shown in Fig. 34-2)	200 % of the requirements of lines 1 – 4		on site

1) For different thermal conductivity values of the insulation thickness has to be recalculated. Reference temperature related to the thermal conductivity is $40 \text{ }^\circ\text{C}$ and for cold water applications $10 \text{ }^\circ\text{C}$.

2) The requirements according No. 3 apply in case of heat exposure.

3) Cold drinking water pipes should not be laid in areas where underfloor heating is installed. If this is necessary, the requirements according to DIN 1988-200 Paragraph 3.6. apply.

4) Additional requirements according to GEG

Tab. 34-2 Recommended values of thickness for the insulation of warm and circulation drinking water pipes according to DIN 1988-200

34.07 Insulation of heating piping according to German Building Energy Law (GEG)

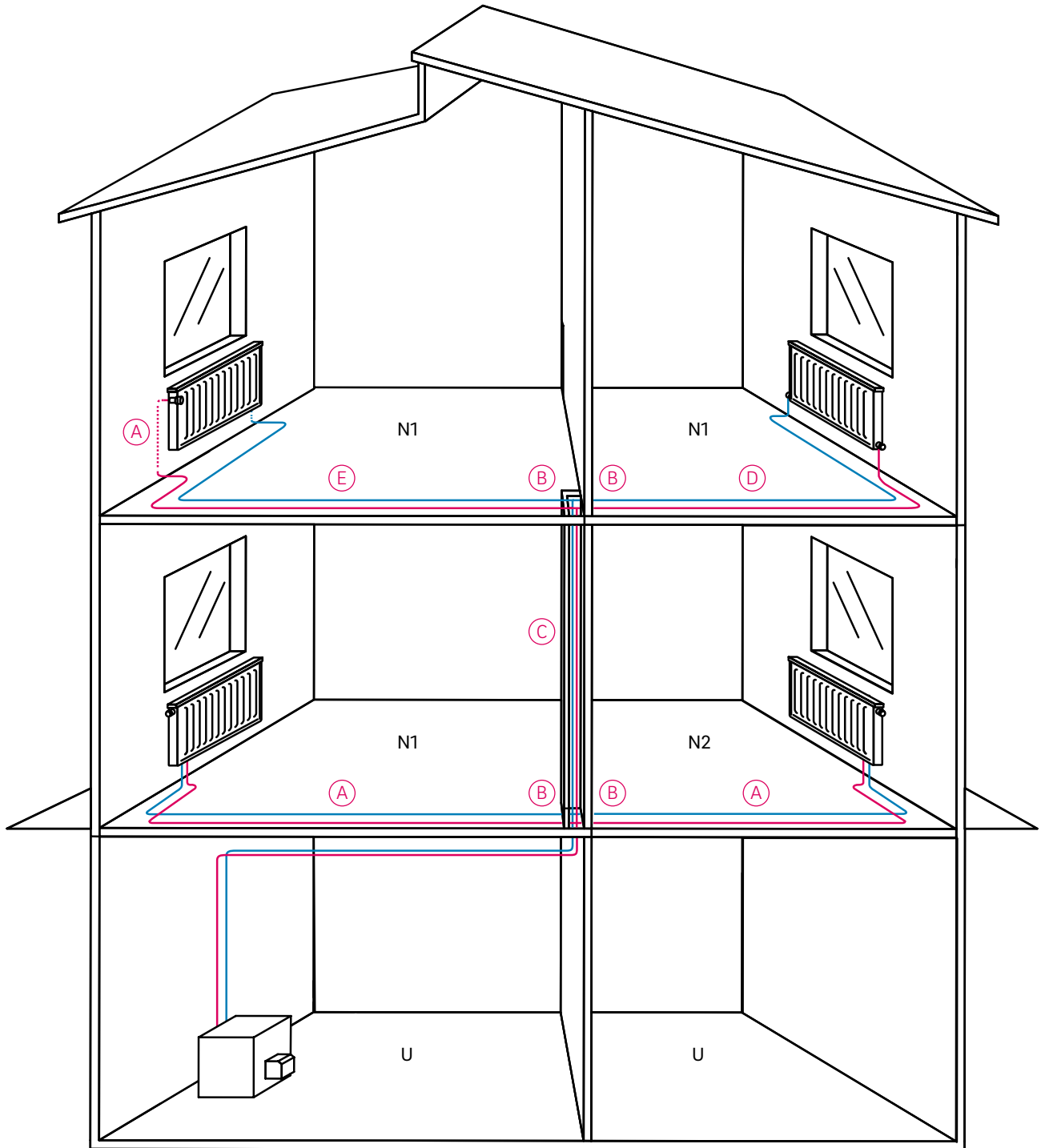











Fig. 34-3 Installation situations of piping insulation

- N1 User 1
- N User 2
- U Unheated

No.	Installation conditions	Minimum thickness of round shape insulations with $\lambda = 0.035 \text{ W}/(\text{m} \cdot \text{K})^1$	pre-insulated in size 16 – 25	
			stabil	flex
	Inner pipe diameter < 22 mm	20 mm	 26 mm $\lambda = 0.04 \text{ W}/(\text{m} \cdot \text{K})$	
(A)	In the floor construction in heated rooms above unheated rooms/in-ground/outside air		 26 mm	 26 mm $\lambda = 0.04 \text{ W}/(\text{m} \cdot \text{K})$
	Inner pipe diameter 22 – 35 mm	30 mm	on site	
	Inner pipe diameter 35 – 100 mm	Same as inner pipe diameter	on site	
	Inner pipe diameter > 100 mm	100 mm	on site	
The generally valid insulation thicknesses can be disregarded in the following installation circumstances:				
(B)	Piping and fittings in the lines under A in wall and ceiling openings, in the crossings of piping, at pipe joints, at central pipe network manifolds	50 % of the requirements in the lines under A	 13 mm $\lambda = 0.04 \text{ W}/(\text{m} \cdot \text{K})$	
(C)	Central heating pipes in the lines under A, which were laid after 31 January 2002 in building sections between the heated rooms of different users.	50 % of the requirements in the lines under A	 13 mm $\lambda = 0.04 \text{ W}/(\text{m} \cdot \text{K})$	
(D)	Pipes laid in the floor construction as under C	6 mm	 9 mm	
(E)	If central heating pipes are in heated rooms as in the lines under A or in sections of the building between the heated rooms of a user, and their thermal emission can be affected by exposed shut-off facilities, no requirements are made of the minimum thickness of the insulation. This also applies to hot water pipes with a maximal length of 4 m, which are not included in the circulation system or are equipped with auxiliary electric heating.	No requirements  Insulation must nevertheless be implemented for the following reasons: <ul style="list-style-type: none"> ▪ Reduction of heat loss ▪ Sound insulation ▪ Protection of the piping ▪ etc. 	 4 mm $\lambda = 0.04 \text{ W}/(\text{m} \cdot \text{K})$	

1) In case of different thermal conductivities, the insulation thickness must be recalculated. The reference temperature for the specified thermal conductivity is 40 °C or 10 °C for cold water applications.

Tab. 34-3 Recommended values of thickness for the insulation of heating installation

34.08 Pre-insulated pipes - Applications

Area of application

Heating systems on raw floor

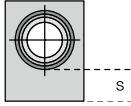
Type	 <p>Eccentric rectangular shape</p>
Pipe sizes	16 / 20
Thermal conductivity (at 40 °C)	equivalent to round insulation with $\lambda = 0.040 \text{ W}/(\text{m} \cdot \text{K})$
Material	<p>PE foam insulation</p> <ul style="list-style-type: none"> ▪ Closed-cell extruded ▪ With co-extruded, PE film moisture barrier
Properties/Benefits	<ul style="list-style-type: none"> ▪ Restriction of heat loss ▪ Proof of equivalence for insulation with eccentric room shape (test report with calculation of equivalent heat output to concentric insulation with thermal conductivity group WLG 040, Fraunhofer Institute for Building Physics IBP, Stuttgart) ▪ High stability on the raw floor ▪ Greater acceptance from succeeding contractors (e.g. screed layers) due to the shape ▪ No additional laying of a compensating layer as per DIN 18560-2 necessary (test certificate for impact sound reduction of a floating screed with inserted, water-filled, insulated pipes, Fraunhofer Institute for Building Physics IBP, Stuttgart) ▪ Better application of impact sound insulation ▪ Low height above the floor

Example installations

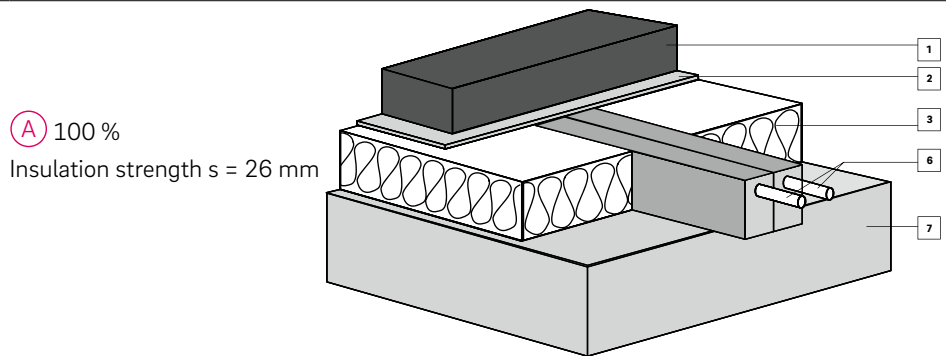

(B) (C) 50 %

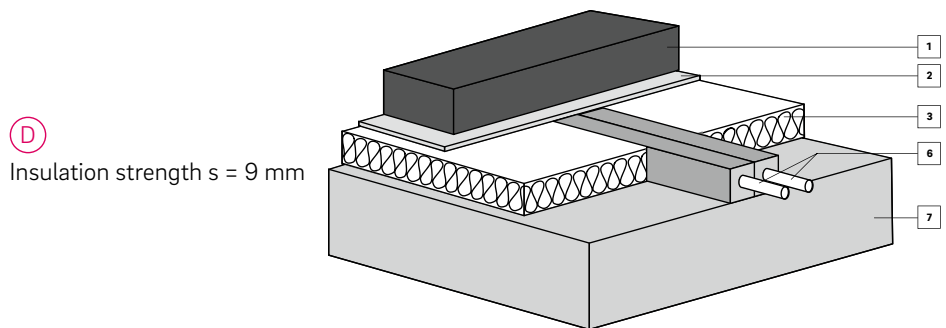

(E) No requirement

Possible use

Tab. 34-4 Factory pre-insulated pipes

- Application heating water according to GEG
- Application cold water according to DIN 1988-200
- ◇ Application hot water according to DIN 1988-200
- 1 Screed
- 2 Film

- 3 Heat insulation/Impact sound insulation
- 4 Bonded aggregate
- 5 Compensating layer
- 6 Pipe
- 7 Rough floor

Drinking water and heating installation

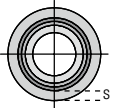

Round shape

16 / 20 / 25 / 32

$\lambda = 0.040 \text{ W/(m} \cdot \text{K)}$

PE foam insulation

- Closed-cell extruded
- With co-extruded, PE film moisture barrier

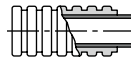

Protective pipe

16 / 20

–

- Corrugated polyethylene pipe
- Flexible

- Protection against the formation of condensation water, heating and cooling of piping according to DIN 1988-200
- Restriction of heat loss
- Can be laid as required on rough floors, in shafts and wall openings

- Protection against condensation according to DIN 1988-200
- At expansion joint crossings
- As protection at the pipe entries to manifolds
- No soft elastic insulation material as per DIN 4109

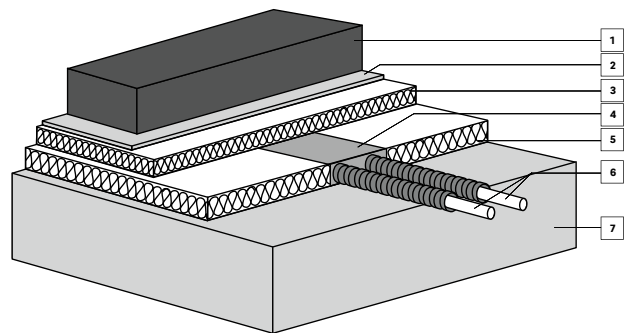
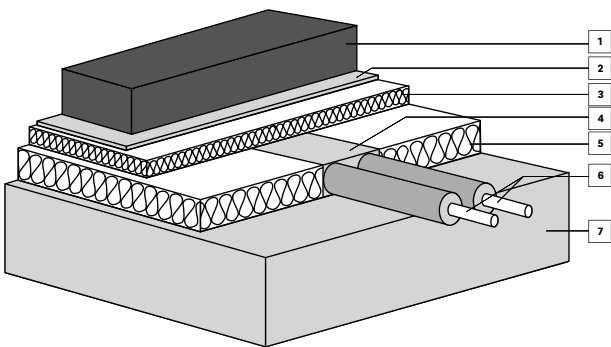

- (A) ① Insulation strength $s = 26 \text{ mm}$
- (B) (C) ⑥ ⑤ Insulation strength $s = 13 \text{ mm}$
- (D) ① ⑥ Insulation strength $s = 13 \text{ mm}$
- (E) ④ ⑤ ⑥ Insulation strength $s = 4 \text{ mm}$

- (E) ④ ⑤ ⑥

35 Noise protection

The specifications in this chapter only apply to

stabil	Universal pipe RAUTITAN stabil
flex	Universal pipe RAUTITAN flex

35.01 Preventative measures to reduce the creation of sound

Ground plan arrangement

- Planning locations of rooms requiring insulation adjacent to bathrooms and WCs should be avoided
- Acoustically advantageous arrangement of bathroom objects, fittings and piping

Planning and design of the piping systems

- Using the universal system RAUTITAN for drinking water and heating (acoustic insulation properties)
- Reduction of the line pressure
- Consideration of the flow velocities
- Selection of pipe and fitting fastenings
- Use of low-noise fittings

Execution of the piping systems

- Avoidance of structure-borne noise bridges
- Avoidance of direct contact of connection components and pipes with the building
- All pipes insulated
- Use of soft and elastic insulating materials (e.g. factory pre-insulated pipes with closed-cell foamed PE insulation)
- Use of pipe clamps with acoustic insulation inserts
- Use of insulating boxes

35.02 Benefits of using the universal system RAUTITAN for drinking water and heating



Fig. 35-1 Insulation box elbow RAUTITAN



Fig. 35-2 Insulation box Rp $\frac{1}{2}$ elbow with passage



- Acoustic insulation properties of the RAU-PE-Xa pipe material
- Acoustic insulation of the REHAU elbow Rp $\frac{1}{2}$ with REHAU insulating box Rp $\frac{1}{2}$ long/short
- Sound insulation of the tees with the insulating box
- Pre-insulated pipes
- For insulation with eccentric shapes, no additional laying of a compensating layer necessary as specified in DIN 18560-2 (test certificate for impact sound reduction of a floating screed with inserted, water-filled, insulated pipes, Fraunhofer Institute for Building Physics IBP, Stuttgart)

35.03 Noise insulating properties of the piping

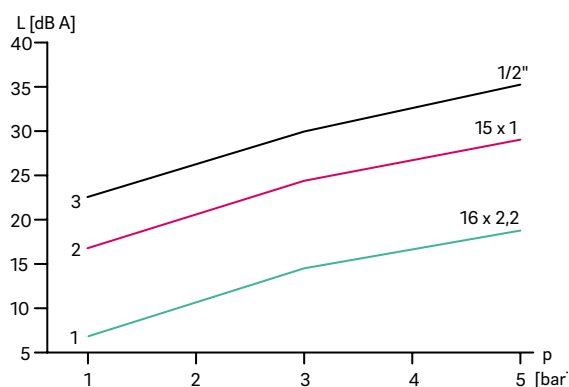

Fig. 35-3 Result of Fraunhofer Institute test report:
Comparison of pipe materials

- L Sound level
- p Flow pressure
- 1 Plastic pipe made of RAU-PE-Xa
- 2 Copper pipes
- 3 Galvanized steel pipes DN 15

Noises are propagated partly in the pipe walls and partly in the water column. The piping transmits vibration to the wall and ceiling. In comparison with metal pipes, pipes made of RAU-PE-Xa (former designation RAU-VPE) transmit only little of the structure-borne noise.

The Fraunhofer Institute for Structural Physics examined the noise transmission properties of pipes made of RAU-PE-Xa (RAU-VPE), copper and galvanized steel. The noise levels of pipes in the three most common size ratings were measured under the same conditions of flow pressure and flow rate and were compared with each other. The results of this overall noise examination are depicted graphically (see Fig. 35-3).

The results of the overall noise examination demonstrate a clearly lower development of noise with the pipes made of RAU-PE-Xa in comparison with metal pipe installations. They were therefore classified as the most favourable to achieve low-noise installations.

§

Certification of individual system components (e.g. insulating boxes) is not required by DIN 4109, Sound insulation in buildings.

With metal/plastic composite pipes (e.g. universal pipe RAUTITAN stabil), the lower noise levels of the plastic pipes (RAU-PE-Xa) are not achieved due to the material combination. However, they are below the values of purely metallic piping systems.

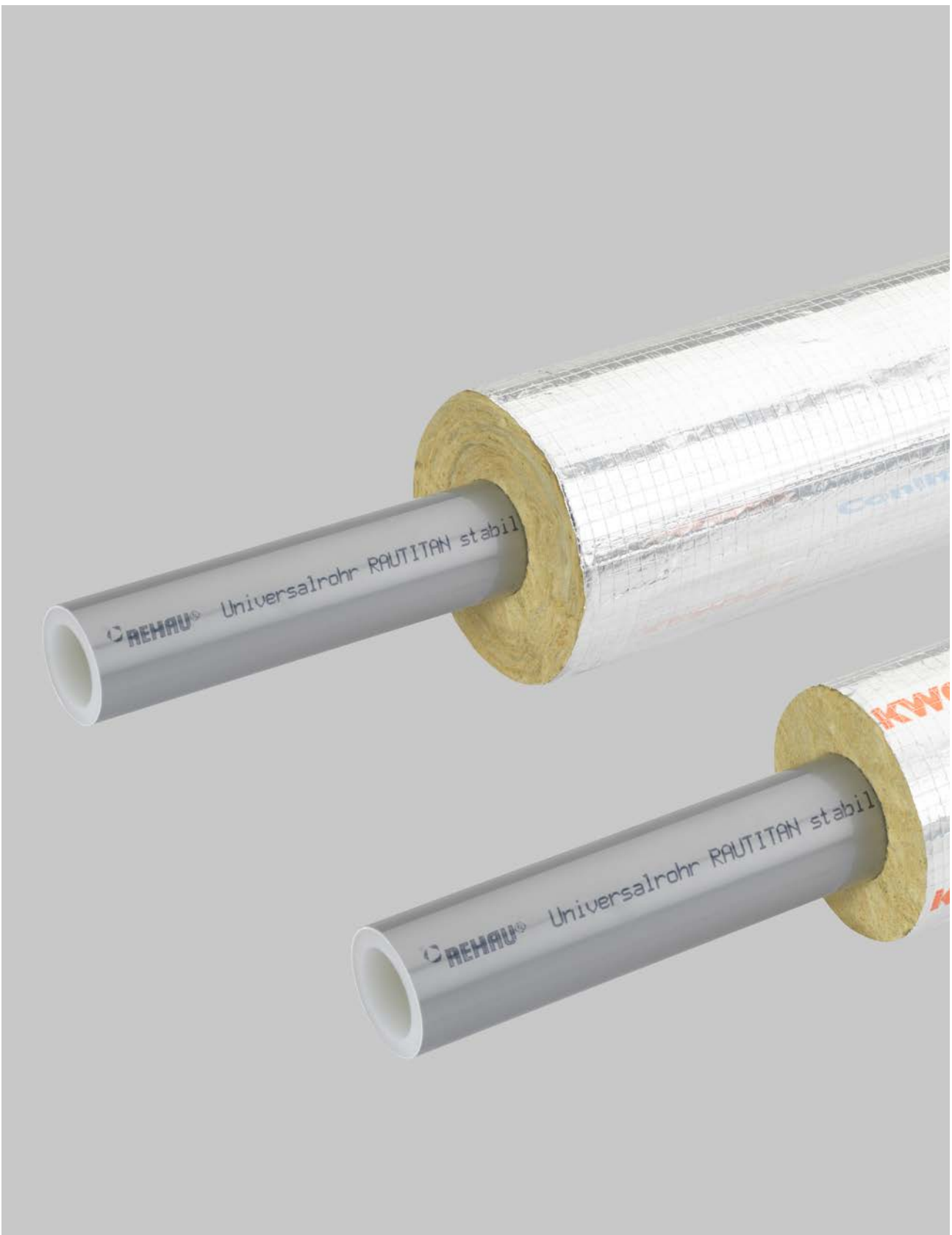

Fire protection

Contents

36 Fire protection

Country-specific modifications required!



System guidelines, planning and assembly

Contents

37	Important instructions for connecting the pipes RAUTITAN stabil, the compression sleeves RAUTITAN PX stabil and fittings RAUTITAN RX+ stabil as RAUTITAN SX stabil in the sizes 50 and 63	142		
37.01	Universal Plumbing system for potable water and heating installations	142		
37.02	RAUTOOL	143		
38	Transport and storage	144		
39	Pipes	145		
39.01	PE-X materials	145		
39.02	Material – Pipe (overview)	145		
39.03	Areas of application: Pipes for plumbing applications	146		
39.04	Areas of application: Pipes in underfloor heating/cooling	146		
39.05	Areas of application: Industrial applications	146		
39.06	Universal pipe RAUTITAN stabil	147		
39.07	Universal pipe RAUTITAN flex	148		
39.08	Gas pipe RAUTITAN gas stabil	149		
39.09	Technical data of pipes	150		
40	Fittings and compression sleeves	151		
40.01	Differentiating the fittings and compression sleeves	151		
40.02	Fittings and compression sleeves of the RAUTITAN system	152		
41	Fittings and compression sleeves	155		
41.01	Differentiating the fittings and compression sleeves	155		
41.02	Fittings and compression sleeves of the RAUTITAN system	156		
41.03	Transition to other pipe materials	159		
41.04	Transition to other pipe materials	160		
41.05	Connection to fittings	166		
41.06	Installation notes for connection components and valves	166		
42	System tools RAUTOOL	169		
42.01	Compression sleeve tools RAUTOOL (part of the product program)	170		
42.02	Pipe shears	172		
42.03	Pipe shears 16/20 RAUTITAN	173		
42.04	Pipe shears 25	173		
42.05	Pipe shears 40 stabil	173		
42.06	Roll tube cutter	173		
42.07	Pipe shears 63	173		
43	Expanding tools	174		
43.01	Expander heads and expander bits for pipes	174		
43.02	Expander bits	175		
43.03	Safety advice on the expander heads	176		
44	Making the compression sleeve joint	177		
44.01	Important advices	177		
44.02	Processing the compression sleeve joint sizes 16 to 40	178		
44.03	Processing the compression sleeve connection with RAUTITAN 50 and 63	181		
45	Detaching the compression sleeve joint	184		
45.01	Cutting out the joint	184		
45.02	Usability of cut-out joints	184		
46	Detaching the compression sleeve joint	185		
46.01	Cutting out the joint	185		
46.02	Usability of cut-out joints	185		
46.03	Detaching the cut-out joint from drinking water and heating installations	186		
47	Bending the pipes	187		
47.01	Bending the universal pipe RAUTITAN stabil and gas pipe RAUTITAN gas stabil	187		
47.02	Bending the universal pipe RAUTITAN flex	188		
48	Pipe support channel	190		
48.01	Benefits of using the pipe support channel	190		
48.02	Functionality	190		
48.03	Assembly of the pipe support channel	190		
49	Pipe fastening	192		
49.01	Pipe clamps	192		
49.02	Fixed point installation	192		
49.03	Pipe clamp intervals	192		
49.04	Laying in visible areas	192		
50	Thermal length changes	194		
50.01	Guidelines	194		
50.02	Calculation of length changes	194		
51	Deflection legs	195		
51.01	Calculation of deflection leg length	196		
51.02	Calculation examples	196		
51.03	Calculation diagrams to determine deflection legs	197		

52	Fundamental regulations on laying pipes	199
52.01	Pipe installation in areas subject to frost	199
52.02	Laying on the raw floor	199
52.03	Inadmissible heating of pipes	199
52.04	Laying on bitumen sheeting and bitumen coatings	200
52.05	Laying under hot asphalt screed	200
52.06	External installation	201
52.07	Laying exposed to UV radiation	201
52.08	Light transmission	202
52.09	Auxiliary heating	202
52.10	Potential compensation	202
53	Advices about system components until 2019	203
53.01	Advices about fitting contours when using the universal pipe RAUTITAN stabil, size: 16–32	203
53.02	Fittings RAUTITAN MX: Fittings for plumbing applications up to 2013	204
53.03	Transition to other pipe materials	204
53.04	Fire collars RAU-VPE	204
54	Advices about system components until 2013	205
54.01	RAUTHERM SL	205
54.02	Advices about fitting contours when using the universal pipe RAUTITAN stabil, size: 16–32	205
54.03	Fittings MX: Fittings for drinking water and heating application up to 2013	205
54.04	Notes on the compression jaws in size 40 by 2009	206
54.05	Notes on the expanding tool QC and the expanding tool RO	207

37 Important instructions for connecting the pipes RAUTITAN stabil, the compression sleeves RAUTITAN PX stabil and fittings RAUTITAN RX+ stabil as RAUTITAN SX stabil in the sizes 50 and 63

37.01 Universal Plumbing system for potable water and heating installations

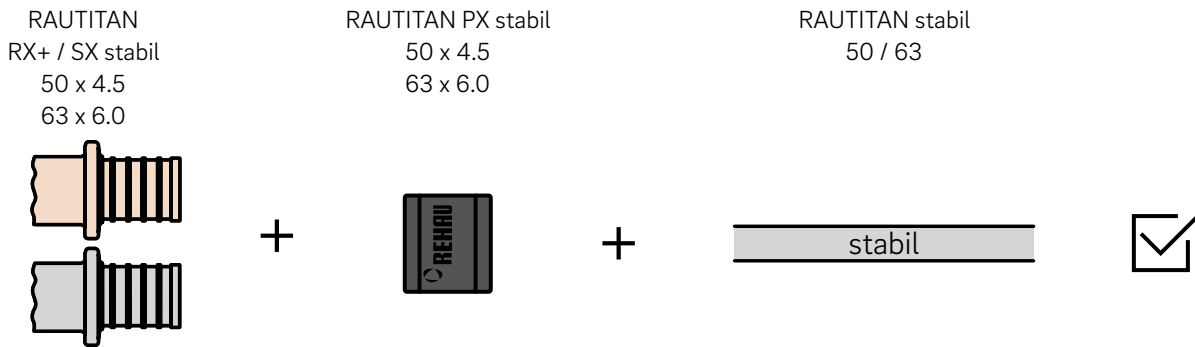

Fig. 37-1 Permitted combination



Different system dimensions

Pipes RAUTITAN flex, fittings RAUTITAN LX/RX/RX+/SX and the compression sleeves LX/MX in sizes 50 x 6.9 und 63 x 8.6 are not compatible with the pipes RAUTITAN stabil 50 x 4.5 und 63 x 6.0 , the fittings RAUTITAN RX+ stabil, RAUTITAN SX stabil and the compression sleeves RAUTITAN PX stabil.

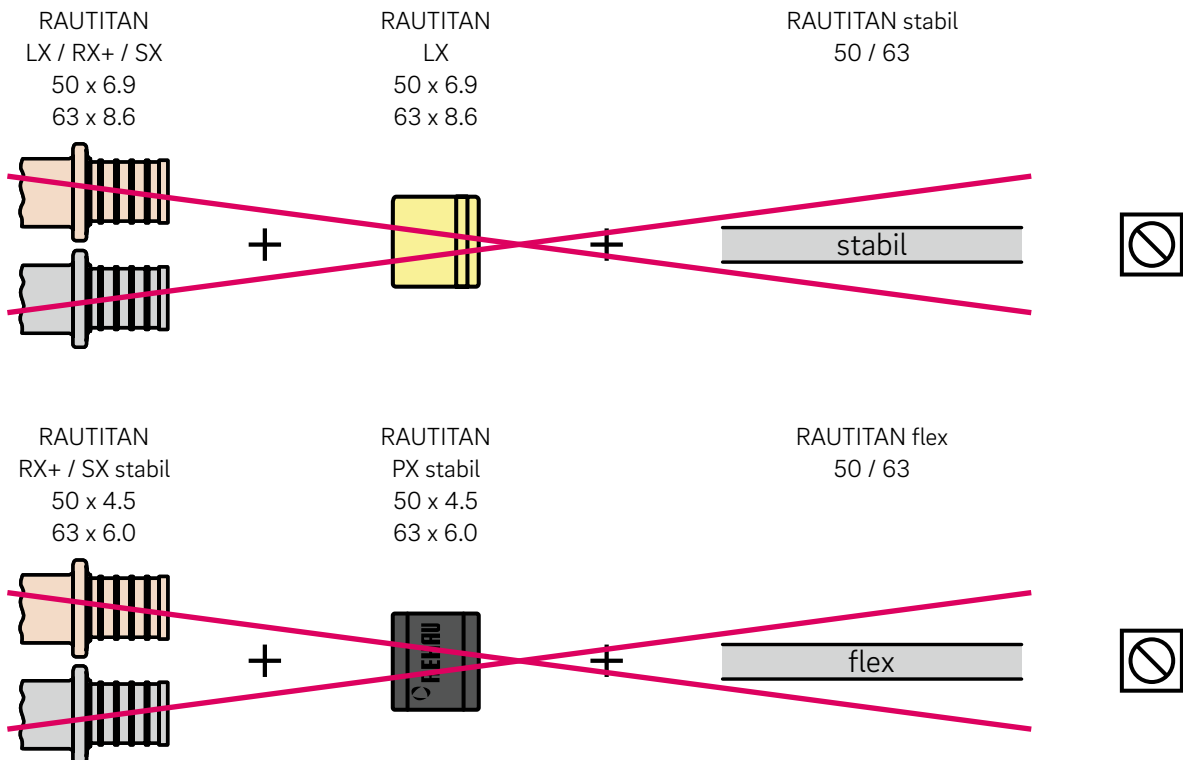

Fig. 37-2 Prohibited combination

37.02 RAUTOOL

	For RAUTITAN stabil Ø 50 x 4.5 / 63 x 6.0		For RAUTITAN flex Ø 50 x 6.9 / 63 x 8.6	RAUTITAN PX stabil Ø 50 x 4.5 / 63 x 6.0
Mat.-Nr. 13258201001 13258211001		+		
Mat.-Nr. 10011281001 10011331001		+		

Tab. 37-1 RAUTOOL for the pipes RAUTITAN stabil, the compression sleeves RAUTITAN PX stabil and fittings RAUTITAN RX+ stabil in sizes 50 and 63



Different system dimensions

The working tool G, both expansion heads and compression jaws are not compatible with the pipes RAUTITAN stabil 50 x 4.5 and 63 x 6.0, the fittings RAUTITAN RX+ stabil as RAUTITAN SX stabil and compression sleeves RAUTITAN PX stabil.

Expansion head A5
and Xpand big
50 x 6.9
63 x 8.6

RAUTITAN stabil
50 / 63

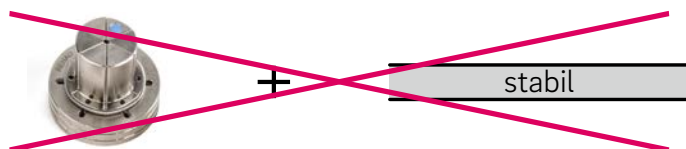

Expansion head G
50 x 6.9
63 x 8.6

RAUTITAN stabil
50 / 63

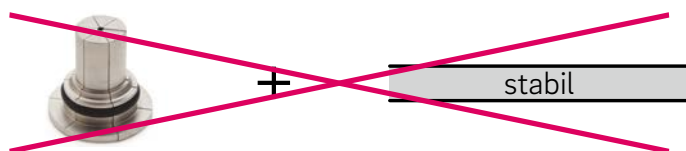

Fig. 37-3 Prohibited expansion tools

38 Transport and storage

Handling the pipes and system components

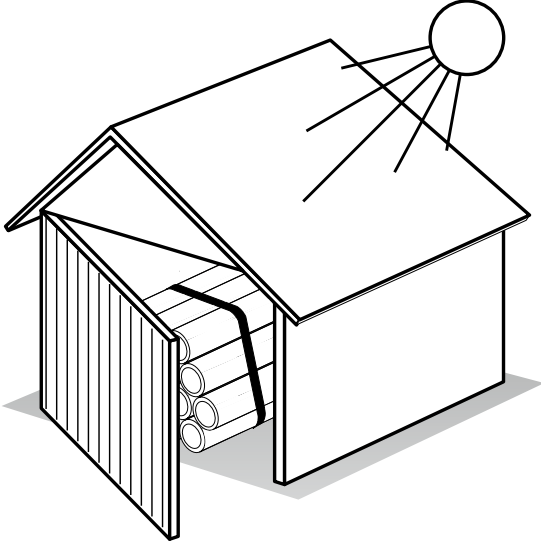

Fig. 38-1 Protect pipes against sunlight

Store and transport pipes and components protected against UV radiation.

Avoid damaging the pipes and system components:

- Load and unload with due care.
- Convey suitably for the materials.
- Do not drag over floors or concrete surfaces.
- Store on a flat surface with no sharp edges.
- Protect against mechanical damage.
- Protect against dirt, drilling dust, mortar, grease, oil, paint, solvents, chemicals, humidity, etc.
- Protect against sunlight, e.g. with an opaque film or similar material.
- Protect against long sunlight during the building phase.
- Only unpack shortly before laying.
- Note the hygienic requirements (e.g. sealing of pipe ends, protection of the fittings, compliance with VDI 6023).
- Hygiene-conscious planning, execution, operation and installation of drinking water systems.

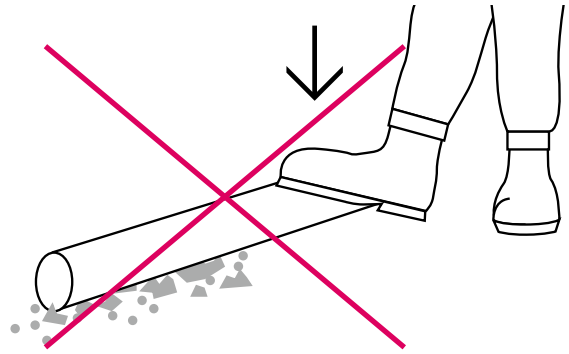

Fig. 38-2 Do not store pipes on sharp-edged surfaces

39 Pipes

39.01 PE-X materials

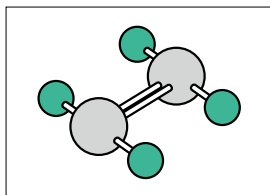

Fig. 39-1 Ethylene

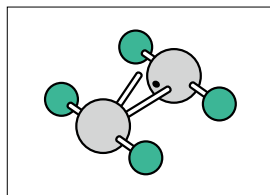

Fig. 39-2 Ethylene, detaching double bond

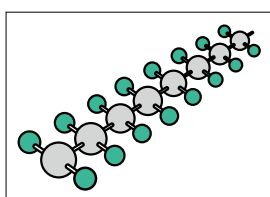

Fig. 39-3 Polyethylene (PE)

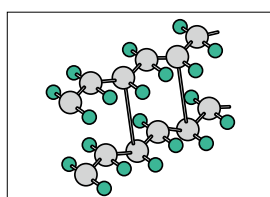

Fig. 39-4 Crosslinked polyethylene (PE-X)



- Corrosion resistance of the pipes: No pitting
- No tendency to deposits
- Polymer pipe material reduces sound transmission along the pipe
- Good resistance to abrasion
- Toxicologically and physiologically harmless
- All RAUTITAN pipes with DVGW registration comply with the Evaluation criteria for plastics and other organic materials in contact with drinking water

Peroxide-crosslinked polyethylene

Peroxide-crosslinked polyethylene is designated PE-Xa. This method of crosslinking is conducted at high temperatures and pressure with the aid of peroxides. Here, the individual molecules of the polyethylene combine to form a three-dimensional network. This high-pressure crosslinking is characterised by crosslinking in the melt away from the crystallite melting point. Crosslinking occurs during the moulding of the pipe in the tool. This method of crosslinking ensures an even and very high degree of crosslinking over the entire cross-section of even thick-walled pipes.

Radiation crosslinked polyethylene

Radiation crosslinked polyethylene is designated PE-Xc. Crosslinking is conducted after the production of the pipes under the effects of high-energy radiation.

Inliner universal pipe RAUTITAN stabil and gas pipe RAUTITAN gas stabil

The inliner pipe in the universal pipe RAUTITAN stabil and in the gas pipe: RAUTITAN gas stabil, which comes into contact with the flowing medium, is known as inliner. This inliner is made of cross-linked polyethylene (PE-X).

39.02 Material – Pipe (overview)

Composition / Material	Pipe
▪ Self-supporting PE-X inliner (sizes 16 to 40), pressure-resistant and crosslinked	Universal pipe RAUTITAN stabil
▪ Aluminium layer	Gas pipe RAUTITAN gas stabil
▪ Polyethylene outer layer	gas stabil
▪ RAU-PE-Xa	Universal pipe RAUTITAN flex
▪ Adhesive agent	flex
▪ Oxygen diffusion barrier	

Tab. 39-1 Pipe composition/material (composition from interior to exterior)

39.03 Areas of application: Pipes for plumbing applications

	Universal pipe RAUTITAN stabil stabil	Universal pipe RAUTITAN flex flex	Gas pipe RAUTITAN gas gas stabil	Heating pipes RAUTHERM S/ SPEED	Industrial pipes
Drinking water	++	++	-	-	-
Heating	++	++	-	-	-
Radiator connection from the skirting	++	-	-	-	-
Underfloor heating/cooling	+	+	-	++	-
Gas	-	-	++	-	-

++ Use permitted

+ Application possibilities must be taken from the technical manual „Underfloor heating/cooling“

- Use not permitted

39.04 Areas of application: Pipes in underfloor heating/cooling

Installation system	Universal pipe RAUTITAN stabil	Universal pipe RAUTITAN flex
Studded panel Varionova <ul style="list-style-type: none"> ▪ impact noise insulation 30-2 ▪ thermal insulation 11 mm ▪ without impact sound insulation 	16.2 x 2.6 mm	16 x 2.2 mm
Stapler system	16.2 x 2.6 mm / 20 x 2.9 mm	16 x 2.2 mm / 20 x 2.8 mm
for 12/14	-	-
RAUFIK rail		
for 16/17/20	16.2 x 2.6 mm	16 x 2.2 mm 20 x 2.8 mm
Pipe grid	16.2 x 2.6 mm / 20 x 2.9 mm	16 x 2.2 mm / 20 x 2.8 mm
Dry fit system	16.2 x 2.6 mm	16 x 2.2 mm
Base plate TS-14	-	-
Cooling ceiling	-	-
Acoustic chilled ceiling	-	-
Wall heating/cooling in drywall/in wetwall	-	-
Modernisation system for the floor	-	-
Ceiling in wetwall construction	-	-
Pipe fixing panel RAUTAC 10	16.2 x 2.6 mm	16 x 2.2 mm

39.05 Areas of application: Industrial applications

	Industrial pipe RAUPEX	Industrial pipe RAUTHERM-FW	Pre-insulated industrial pipe RAUFRIGO
Compressed air	++	-	-
Vacuum	++	-	-
Inert Gas	++	-	-
Cooling water	++	-	+
Water for industrial use	++	-	-
Industrial heating	-	++	-
Refrigerant medium transport	+	-	++

++ Use permitted

+ Use permitted with limitation

- Use not permitted

39.06 Universal pipe RAUTITAN stabil



Fig. 39-5 Universal pipe RAUTITAN stabil

- Metal/plastic composite pipe with the following structure:
 - Self-supporting inliner (pressure-resistant inner tube) made of crosslinked polyethylene (PE-X)
 - Oxygen-diffusion tight aluminium layer
 - Polyethylene outer layer
- Areas of application
 - Drinking water installation
 - Heating installation



RAUTITAN pipe delivered with pre-assembled stoppers for a transport and a storage under optimal hygienic conditions.

Approvals for Germany and quality certificates

- DVGW registration for universal pipe RAUTITAN stabil and compression sleeve jointing technique from REHAU with RAUTITAN connection components
- System approvals for sizes 16–63: DVGW DW-8501AU2346 and DVGW DW-8803CT0532
- The universal pipe RAUTITAN stabil complies with DIN EN ISO 21003 - application classes 1-5 / 1 MPa (10 bar).

Approvals outside of Germany

National approvals outside Germany may differ from the German approvals in the respective countries. If the RAUTITAN system is used in other countries, consult your REHAU sales office.

Pipe size

d [mm]	s [mm]	DN ¹⁾ [mm]	Aluminium thickness [mm]	Content [l/m]
16.2	2.6	12	0.2	0.095
20	2.9	15	0.3	0.158
25	3.7	20	0.4	0.243
32	4.7	25	0.4	0.401
40	6.0	32	0.5	0.616
50	4.5	40	0.6	1.320
63	6.0	50	0.8	2.043

1) This information should help choose the installation devices or as an orientation during the first design estimation. The exact pipe inner diameter is $d - 2 \times s$ and has to be used during the installation design.

Tab. 39-2 Pipe size, universal pipe RAUTITAN stabil

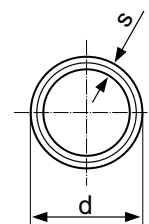

Fig. 39-6 Diameter/Wall thickness

39.07 Universal pipe RAUTITAN flex



Fig. 39-7 Universal pipe RAUTITAN flex

- Pipe made from RAU-PE-Xa
 - Peroxide-crosslinked polyethylene (PE-Xa)
 - With oxygen diffusion barrier
 - Oxygen-tight according to DIN 4726
- Areas of application
 - Drinking water installation
 - Heating installation



RAUTITAN pipe delivered with pre-assembled stoppers for a transport and a storage under optimal hygienic conditions.

Approvals for Germany and quality certificates

- DVGW registration for universal pipe RAUTITAN flex and compression sleeve jointing technique from REHAU with RAUTITAN connection components
- System approval:
DVGW DW-8501AU2200
- The universal pipe RAUTITAN flex complies with DIN EN ISO 15875
- DIN CERTCO registration confirms the suitability of the pipes for use in the heating installation to DIN 4726/DIN EN ISO 15875 - application class 1–4 / 1 MPa (10 bar) and 5 / 0.8 MPa (8 bar) and the necessary tightness against oxygen diffusion

Approvals outside of Germany

National approvals outside Germany may differ from the German approvals in the respective countries. If the RAUTITAN system is used in other countries, please consult your REHAU sales office.

Pipe size

d [mm]	s [mm]	DN¹⁾ [mm]	Content [l/m]
16	2.2	12	0.106
20	2.8	15	0.163
25	3.5	20	0.254
32	4.4	25	0.423
40	5.5	32	0.661

1) This information should help choose the installation devices or as an orientation during the first design estimation. The exact pipe inner diameter is $d - 2 \times s$ and has to be used during the installation design.

Tab. 39-3 Pipe size, universal pipe RAUTITAN flex

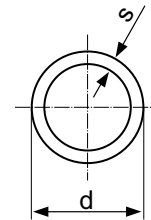

Fig. 39-8 Diameter/Wall thickness

39.08 Gas pipe RAUTITAN gas stabil

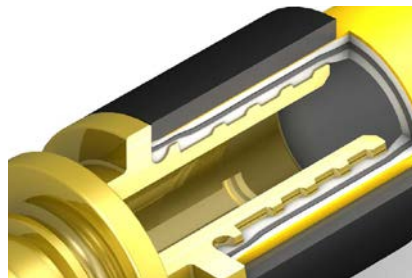

Fig. 39-9 Gas pipe RAUTITAN gas stabil

- Metal/plastic composite pipe with the following structure from the inside outwards:
 - Self-supporting inliner (pressure-resistant inner tube) made of crosslinked polyethylene (PE-X)
 - Oxygen-diffusion tight aluminium layer
 - Polyethylene outer layer
- Area of application
 - Gas installation

Approval for the Netherlands and quality certificates

- [KIWA](#) registration for RAUTITAN gas stabil gas pipe and compression sleeve jointing technique from REHAU with RAUTITAN gas joint components
- System approvals for sizes 16–40: [Q98/002](#)

§

The RAUTITAN gas stabil gas pipe may only be used in the gas installation!

Pipe size

d [mm]	s [mm]	Content [mm]
16.2	2.6	0.095
20	2.9	0.158
25	3.7	0.243
32	4.7	0.401
40	6.0	0.616

Tab. 39-4 Pipe size, gas pipe: RAUTITAN gas stabil

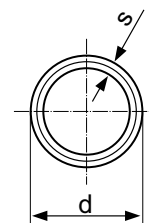

Fig. 39-10 Diameter/Wall thickness

39.09 Technical data of pipes

Technical data	Unit	Pipe		
		Universal pipe RAUTITAN stabil	Universal pipe RAUTITAN flex	Gas pipe RAUTITAN gas stabil
		stabil	flex	gas stabil
Material	–	PE-X/Al/PE	PE-Xa EVAL-sheathed	PE-X/Al/PE
Colour (surface)	–	Silver	Silver	Yellow
Notch impact strength at 20 °C	–	No fracture	No fracture	No fracture
Notch impact strength at –20 °C	–	No fracture	No fracture	No fracture
Average coefficient of expansion		0.026	0.15	0.026
when laying with pipe support channel	[mm/(m·K)]			
Size 16–40		–	0.04	–
Size 50 and 63		–	0.1	–
Thermal conductivity	[W/(m·K)]	0.43	0.35	0.43
Pipe roughness	[mm]	0.007	0.007	0.007
Oxygen diffusion (to DIN 4726)	–	Oxygen-tight	Oxygen-tight	Oxygen-tight
Material constant C	–	33	12	33
Building material class acc. DIN 4102-1	–	B2	B2	B2
Construction product class acc. DIN EN 13501-1	–	E	E	E
Maximum/Minimum laying temperature	[°C]	+50/–10	+50/–10	+50/–10
Minimum bending radius without tools d = Pipe diameter	–	5 x d	8 x d	5 x d
Minimum bending radius with spiral spring/tool d = Pipe diameter	–	3 x d	–	3 x d
Minimum bending radius with pipe bend brackets d = Pipe diameter	–	–	3–4 x d Plumbing 5 x d Plumbing/ Heating	–
Available sizes	[mm]	16–63	16–40	16–40

Tab. 39-5 Technical data of pipes / approximate values









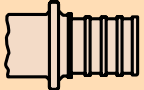

It can happen that singular cases of blistering may occur during operation on the pipe surface of the universal pipe RAUTITAN stabil.

40 Fittings and compression sleeves

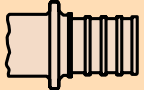
40.01 Differentiating the fittings and compression sleeves

Areas of application of the fittings and compression sleeves

Drinking water installation		Heating installation					
<table border="1"> <tr><td>stabil</td></tr> <tr><td>flex</td></tr> </table>		stabil	flex	<table border="1"> <tr><td>stabil</td></tr> <tr><td>flex</td></tr> </table>		stabil	flex
stabil							
flex							
stabil							
flex							
Fitting	Compression sleeve	Fitting	Compression sleeve				
							
							
							
							

Tab. 40-1 Areas of application of the fittings and compression sleeves

40.02 Fittings and compression sleeves of the RAUTITAN system



- Application in plumbing and heating installation
- Permanently sealing compression sleeve jointing technique according to DIN EN 806, DIN 1988 and DVGW-worksheet W 534
- Approved for flush-mounted installation in accordance with DIN 18380 (VOB)
- Without o-ring (pipe material seals itself)
- Easy optical monitoring
- Can be immediately pressurised
- RAUTITAN RX+ fittings, through which drinking water flows, are made of lead free gunmetal according to DIN SPEC 2701
- DVGW registration (all sizes)
 - For the RAUTITAN pipes in the drinking water installation
 - For the REHAU compression sleeve jointing technique
- Manufacture of the compression sleeve joint with RAUTOOL
 - Especially coordinated with the RAUTITAN and RAUTHERM S systems
 - Development and supervision directly from REHAU



Fig. 40-1 Fittings RAUTITAN PX made from PPSU



Fig. 40-2 Fitting RAUTITAN RX+ (lead free gunmetal)



Fig. 40-3 Fitting RAUTITAN SX (stainless steel)



Fig. 40-4 RAUTITAN compression sleeves



- Only use the fittings and compression sleeves RAUTITAN PX, RAUTITAN RX+ or RAUTITAN SX in the drinking water and heating installation.
- Only push RAUTITAN PX compression sleeves onto RAUTITAN PX fittings.
- Do not confound the RAUTITAN connection components with the connection components of the heating pipe RAUTHERM S (underfloor heating/cooling) (e.g. stainless steel RAUTITAN SX system adapters or radiator connection bend sets). Do not combine fittings and compressions sleeves from different ranges with each other.
- Do not use fittings for the heating installation (as labeled on the packaging) in drinking water installations.
- Please note the measurements of the fittings and compression sleeves.
- You can find the precise assignment of the connection components in the current price list.



For detailed information about the compatibility of the fittings and compression sleeves with existing pipes, please contact your REHAU sales office.

Size designation of the fittings and compression sleeves for the RAUTITAN system

- 16 x 2.2
- 20 x 2.8
- 25 x 3.5
- 32 x 4.4
- 40 x 5.5
- 50 x 4.5
- 63 x 6.0

40.02.01 Fittings

Fittings for drinking water and heating

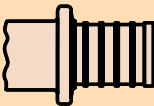
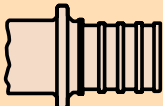
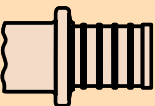
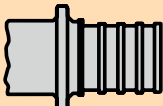
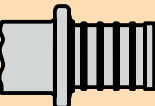
	Size 16–40	Size 50–63
Threadless fittings		
	RAUTITAN PX	RAUTITAN RX+ stabil
Material	PPSU	Gunmetal
	Size 16–40	Size 50–63
Fittings for screwing, soldering, clamping		
	RAUTITAN RX+	RAUTITAN RX+ stabil
Material	Gunmetal	
	Size 16–40	Size 50–63
		
	RAUTITAN SX	RAUTITAN SX stabil
Material	Stainless steel	

Tab. 40-2 Fittings for plumbing and heating installations

Fitting	Material
RAUTITAN PX RAUTITAN PX stabil	Polyphenyl sulphone Material marking: PPSU
RAUTITAN RX+ RAUTITAN RX+ stabil	Lead free gunmetal according to DIN SPEC 2701 (material designation CuSn4Zn2PS) Material marking: Rg+
RAUTITAN SX RAUTITAN SX stabil	Stainless steel (material designations 1.4404/1.4408) The fittings are manufactured according to DIN EN 10088, part 3

Differences of the fittings for the heating installation



Fig. 40-5 Fittings for the heating installation only



- Use RAUTITAN fittings, labeled as heating fittings on the packaging, only in the heating installation (e.g. radiator connection bends, radiator connection tees, cross fittings).
- You can find the precise assignment of the connection components in the current price list.

40.02.02 Compression sleeves

Compression sleeves for the RAUTITAN universal system for drinking water and heating



Fig. 40-6 RAUTITAN PX compression sleeve

RAUTITAN PX RAUTITAN PX stabil



Size	16 x 2.2 mm 20 x 2.8 mm 25 x 3.5 mm 32 x 4.4 mm 40 x 5.5 mm 50 x 4.5 mm 63 x 6.0 mm
Material	PVDF (Polyvinylidene fluoride)
Characteristic features	<ul style="list-style-type: none"> ▪ Can be pushed onto the fitting from both sides ▪ Black













Tab. 40-3 RAUTITAN compression sleeves

- Can be used for all pipe types of the RAUTITAN universal system for drinking water and heating
- Permanently sealing compression sleeve jointing technique
 - According to DIN EN 806, DIN 1988 and DVGW worksheet W 534
 - Approved for flush-mounted installation according to DIN 18380 (VOB)

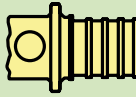
41 Fittings and compression sleeves

41.01 Differentiating the fittings and compression sleeves

Areas of application of the fittings and compression sleeves

Drinking water installation		Heating installation		Gas installation	
stabil		stabil		gas stabil	
flex		flex			
Fitting	Compression sleeve	Fitting	Compression sleeve	Fitting	Compression sleeve
					
					
					
					

Tab. 41-1 Areas of application of the fittings and compression sleeves

41.02 Fittings and compression sleeves of the RAUTITAN system



- Fittings RAUTITAN LX +G and compression sleeves RAUTITAN PX can be used for plumbing and gas applications
- Fittings and compression sleeves RAUTITAN LX as well as fittings RAUTITAN PX can be used for plumbing applications only
- Permanently sealing compression sleeve jointing technique according to DIN EN 806, DIN 1988 and DVGW-worksheet W 534
- Approved for flush-mounted installation in accordance with DIN 18380 (VOB)
- Robust jointing technique, highly suitable for the building site
- Without o-ring (pipe material seals itself)
- Easy optical monitoring
- Can be immediately pressurised
- By expanding the pipe, the internal diameters of the pipes and fittings are hydraulically adjusted to each other
- RAUTITAN LX and RAUTITAN LX +G fittings, through which drinking water flows, are made of standard brass according to DIN EN 1254-3
- DVGW registration (all sizes)
 - For the RAUTITAN pipes in the drinking water installation
 - For the REHAU compression sleeve jointing technique
- Manufacture of the compression sleeve joint with RAUTOOL
 - Especially coordinated with the RAUTITAN and RAUTHERM S systems
 - Development and supervision directly from REHAU



Fig. 41-1 Fittings RAUTITAN PX made from PPSU



Fig. 41-2 RAUTITAN LX (standard brass), RAUTITAN RX+ (gunmetal) and RAUTITAN SX (stainless steel) fittings



Fig. 41-3 RAUTITAN compression sleeves



- Only use the fittings RAUTITAN PX, RAUTITAN LX, RAUTITAN RX+ or RAUTITAN SX in the drinking water and heating installation.
- Only push RAUTITAN PX compression sleeves onto RAUTITAN PX fittings.
- Do not screw threaded fittings RAUTITAN SX made of stainless steel together with threaded fittings RAUTITAN LX made of standard brass.
- Do not confound the RAUTITAN connection components with the connection components of the heating pipe RAUTHERM S (underfloor heating/cooling) (e.g. stainless steel RAUTITAN SX system adapters or radiator connection bend sets). Do not combine fittings and compressions sleeves from different ranges with each other.
- Do not use fittings for the heating installation (as labeled on the packaging) in drinking water installations.
- Please note the measurements of the fittings and compression sleeves.
- You can find the precise assignment of the connection components in the current price list.



For detailed information about the compatibility of the fittings and compression sleeves with existing pipes, please contact your REHAU sales office.

41.02.01 Fittings

Fittings for drinking water and heating

Size designation of the fittings:

- 16 x 2.2
- 20 x 2.8
- 25 x 3.5
- 32 x 4.4
- 40 x 5.5
- 50 x 4.5
- 63 x 6.0

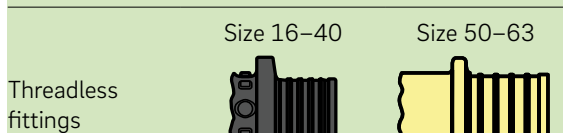

Threadless fittings

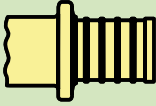
	Size 16-40	Size 50-63
		
	RAUTITAN PX	RAUTITAN RX+ stabil
Material	PPSU	Gunmetal

Material

- RAUTITAN PX / RAUTITAN PX stabil: Polyphenyl sulphone
 - Material marking: PPSU
- RAUTITAN LX / RAUTITAN LX +G: Standard brass (CW 617N) according to DIN EN 1254-3
 - Material marking: without marking
 - Stress cracking resistance
 Fittings and compression sleeves of the RAUTITAN universal system for drinking water and heating satisfy the requirements of stress cracking corrosion resistance in compliance with the DVGW worksheet GW 393.
- RAUTITAN RX+ / RAUTITAN RX+ stabil: Gunmetal
 - CuSn4Zn2PS
 - Material marking: Rg+
- RAUTITAN SX: Stainless steel (material designations 1.4404/1.4408)
 - The fittings are manufactured according to DIN EN 10088, part 3

Material

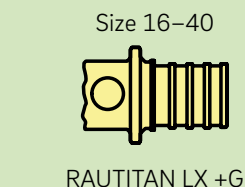

RAUTITAN LX +G
Standard brass

Material

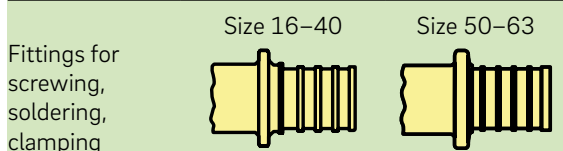

Fittings for screwing, soldering, clamping

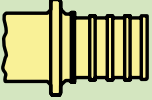
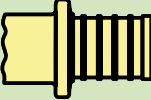
	Size 16-40	Size 50-63
		
	RAUTITAN LX	RAUTITAN RX+ stabil
Material	Standard brass Gunmetal	Gunmetal

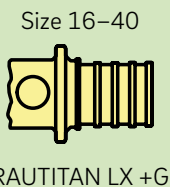

Material

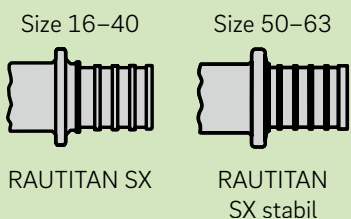

RAUTITAN LX +G
Standard brass

Material

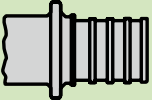

	Size 16-40	Size 50-63
		
	RAUTITAN SX	RAUTITAN SX stabil
Material	Stainless steel	

Material

Differences of the fittings for the heating installation

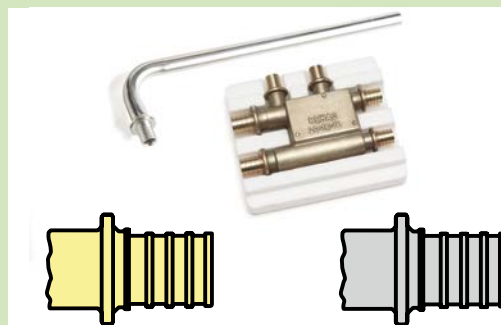

Fig. 41-4 Fittings for the heating installation only





- Use RAUTITAN fittings, labeled as heating fittings on the packaging, only in the heating installation (e.g. radiator connection bends, radiator connection tees, cross fittings).
- You can find the precise assignment of the connection components in the current price list.

Tab. 41-2 Fittings for plumbing and heating installations

Fittings for gas installation

Size designation of the fittings:

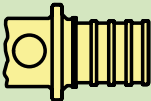
- 16 x 2.2
- 20 x 2.8
- 25 x 3.5
- 32 x 4.4
- 40 x 5.5
- 50 x 6.9
- 63 x 8.6

Threadless fittings	Size 16–63	Size 16–40
		
	RAUTITAN LX +G	RAUTITAN PX
Material	Brass	PPSU
Fittings for screwing, soldering, clamping	Size 16–63	
		
	RAUTITAN LX +G	
Material	Brass	

Tab. 41-3 Fittings for gas installation

Differences of the fittings for the gas installation



- Only use RAUTITAN LX +G fittings in the gas installation.
- These are made of brass and identified with a yellow marking.
- Do not use any RAUTITAN PX, RAUTITAN LX/MX, RAUTITAN RX+ or RAUTITAN SX fittings for gas applications.
- You can find the precise assignment of the connection components in the current price list.

41.02.02 Compression sleeves

Compression sleeves for the RAUTITAN universal system for drinking water and heating

RAUTITAN PX RAUTITAN PX stabil	
	
Size	16 x 2.2 mm 20 x 2.8 mm 25 x 3.5 mm 32 x 4.4 mm 40 x 5.5 mm 50 x 4.5 mm 63 x 6.0 mm
Material	PVDF (Polyvinylidene fluoride)
Characteristic features	<ul style="list-style-type: none"> ▪ Can be pushed onto the fitting from both sides ▪ Black

Tab. 41-4 RAUTITAN compression sleeves

- Can be used for all pipe types of the RAUTITAN universal system for drinking water and heating
- Permanently sealing compression sleeve jointing technique
 - According to DIN EN 806, DIN 1988 and DVGW worksheet W 534
 - Approved for flush-mounted installation according to DIN 18380 (VOB)

Compression sleeve for gas applications

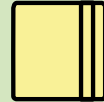
	RAUTITAN PX	RAUTITAN LX
		
Size	16 x 2.2 mm 20 x 2.8 mm 25 x 3.5 mm 32 x 4.4 mm 40 x 5.5 mm	50 x 6.9 mm 63 x 8.6 mm
Material	PVDF (Polyvinylidene fluoride)	Thermally annealed brass to DIN EN 1254-3
Characteristic features	<ul style="list-style-type: none"> ▪ Can be pushed onto the fitting from both sides ▪ Black 	<ul style="list-style-type: none"> ▪ Can only be pushed onto the fitting from one side ▪ Brass finish ▪ An encircling groove

41.03 Transition to other pipe materials



Fig. 41-5 RAUTITAN RX+ (lead free gunmetal) fittings



Fig. 41-6 RAUTITAN SX (stainless steel) fitting



- Only make joints after the soldering process.
- Let the solder cool down fully.
- A direct connection thread between the fitting RAUTITAN SX made of stainless steel and fittings made of galvanised steel is according to DIN EN 806-4 not allowed.

We recommend for that the use of a non ferrous metal transition fitting (e.g. gunmetal).

- To extend the thread fittings RAUTITAN we recommend the use of thread pieces made of gunmetal.

E.g. if repairs or piping network extensions make a system change to the RAUTITAN system or to the REHAU systems for underfloor heating/cooling necessary, a threaded joint must always be used to preserve the guarantee and as a clear division between the different systems.

An exception to this rule is the use of the soldering/pressing adapter RAUTITAN RX+ and the RAUTITAN SX stainless steel system pressing adapter.

For transitions from the RAUTITAN system to soldering or metal compression systems (radial compression joints to DVGW worksheet W 534), use the soldering/pressing adapter RAUTITAN RX+ or RAUTITAN SX.

When using with metal compression systems, ensure that the surfaces of the soldering/compression end are free of grooves and deformations.

Observe the instructions of the metal compression system manufacturers.



Fig. 41-7 Adapter with male thread and soldering/pressing adapter

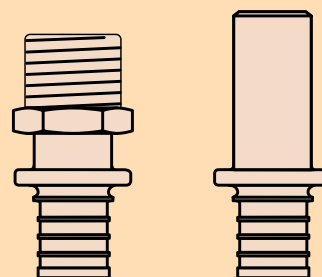

Fig. 41-8 RAUTITAN fittings for transitions to other materials

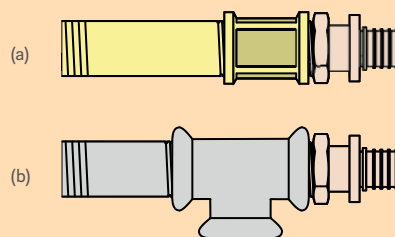

Fig. 41-9 Adapter with RAUTITAN male thread screwed into:
(a) Brass fittings
(b) Systems with galvanised pipes and fittings

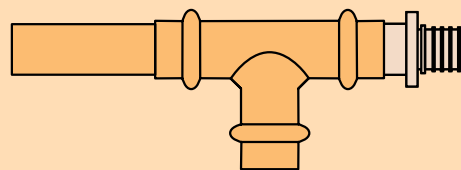

Fig. 41-10 Soldering/Pressing adapter RAUTITAN RX+ with copper pressing system

Use suitable solder and flux for soft-soldering and hard-soldering.

§

Use soft-soldering methods only in the drinking water installation.

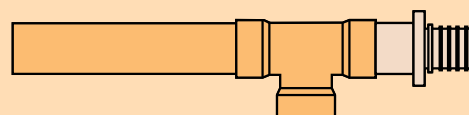

Fig. 41-11 Soldering/Pressing adapter RAUTITAN RX+ soldered into a copper piping system

41.04 Transition to other pipe materials



Fig. 41-12 RAUTITAN LX (brass), RAUTITAN RX+ (gunmetal) und RAUTITAN SX (stainless steel) fittings



Gas piping

- Only use RAUTITAN gas thread adapters for the transition to other pipe material.
- A direct transition to a stainless steel installation system is not permitted. Use a non-stainless steel interim piece for the connection of both systems, e.g. a combination of: RAUTITAN gas thread adapter with male thread – thread socket – thread adapter with male thread made of stainless steel.
- Only use mating threads according to ISO 7-1 and DIN EN 10226-1 (Rp/R).
- A soldered joint with RAUTITAN gas fittings is not permitted.
Only insert solderless joints.

Water piping

- Only make joints after the soldering process.
- Let the solder cool down fully.
- A direct screwed connection of threaded fittings RAUTITAN LX / RAUTITAN LX +G (standard brass) to threaded fittings RAUTITAN SX made of stainless steel is not allowed.
We recommend the use of a transition piece made of gunmetal between both fittings.
- A direct connection thread between the fitting RAUTITAN SX made of stainless steel and fittings made of galvanised steel is according to DIN EN 806-4 not allowed.
We recommend for that the use of a non ferrous metal transition fitting (e.g. gunmetal).
- To extend the thread fittings RAUTITAN we recommend the use of thread pieces made of gunmetal.

E.g. if repairs or piping network extensions make a system change to the RAUTITAN system or to the REHAU systems for underfloor heating/cooling necessary, a threaded joint must always be used to preserve the guarantee and as a clear division between the different systems.

An exception to this rule is the use of the soldering/pressing adapter RAUTITAN RX+ and the RAUTITAN SX stainless steel system pressing adapter.

For transitions from the RAUTITAN system to soldering or metal compression systems (radial compression joints to DVGW worksheet W 534), use the soldering/pressing adapter RAUTITAN RX+ or RAUTITAN SX.

When using with metal compression systems, ensure that the surfaces of the soldering/compression end are free of grooves and deformations.

Observe the instructions of the metal compression system manufacturers.

The material combination of brass with stainless steel has been acknowledged in technical rules for a long time. However, there is a great difference in strength between the stainless steel material and the brass. This is the reason why a threaded joint, in particularly made in small fitting sizes (up to size 32 or with threads up to R1/Rp1) with thin walls can lead to excessive stresses in the brass fitting, this can go unnoticed. Therefore a direct screwed connection of threaded fittings RAUTITAN SX made of stainless steel to threaded fittings RAUTITAN LX / RAUTITAN LX +G or to extension pieces for wall mounted elbow both made of brass is not allowed.

Thick-walled fittings, e.g. flush mounted valves, fittings or threaded adapters in large sizes are less sensitive to these loads and can be screwed with RAUTITAN SX fittings without restrictions.



Fig. 41-13 Adapter with male thread and soldering/presing adapter

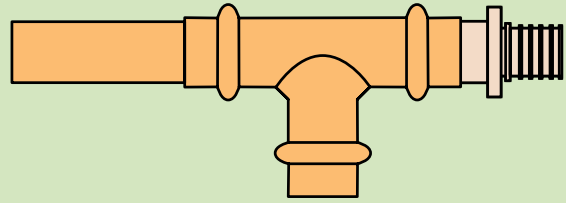

Fig. 41-16 Soldering/Presing adapter RAUTITAN RX+ with copper presing system

Use suitable solder and flux for soft-soldering and hard-soldering.

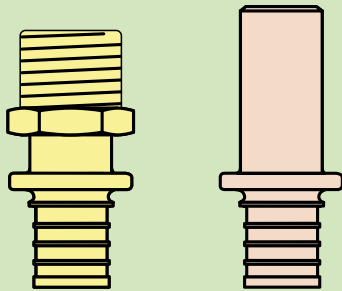

Fig. 41-14 RAUTITAN fittings for transitions to other materials: Thread fitting RAUTITAN MX and soldering/presing adapter RAUTITAN RX+

§

Use soft-soldering methods only in the drinking water installation.

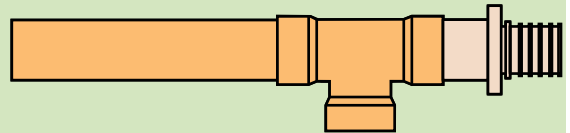

Fig. 41-17 Soldering/Presing adapter RAUTITAN RX+ soldered into a copper piping system

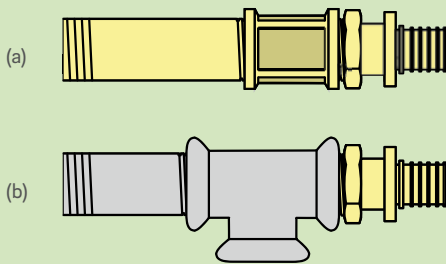

Fig. 41-15 Adapter with RAUTITAN LX male thread screwed into:
 (a) Brass fittings
 (b) Systems with galvanised pipes and fittings

Transition to stainless steel systems



Fig. 41-18 System adapter with stainless steel RAUTITAN SX male thread and stainless steel RAUTITAN SX system pressing adapter



System adapter made of stainless steel

- To connect installation systems made of stainless steel, the use of the system pressing adapters RAUTITAN SX and system adapters with male threads RAUTITAN SX, both in stainless steel is recommended.
- The system pressing adapters are available for metal compression system made of stainless steel with radial compression joints according to DVGW worksheet W 534.
- Do not confound the RAUTITAN SX fittings with the fittings with silver surfaces, which are used to connect the heating pipe RAUTHERM S (underfloor heating/cooling).
- Please note the measurements of the fittings.

Threaded fittings made of stainless steel

- Do not use sealing tape or sealants (e.g. Teflon) which release chloride ions soluble in water.
- Use sealants which do not release chloride ions soluble in water (e.g. hemp).
- To avoid a crevice corrosion of the fittings RAUTITAN SX we recommend the use of hemp as thread sealant.

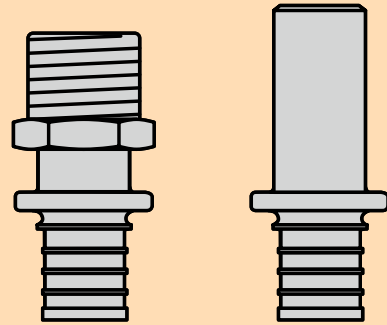

Fig. 41-19 System adapter with stainless steel RAUTITAN SX male thread and stainless steel RAUTITAN SX system pressing adapter

If the RAUTITAN system is connected to other systems made of stainless steel by interconnecting fittings (e.g. flush-mounted valves or water meters), it is unnecessary to use the RAUTITAN SX adapters.

The material combination of copper alloy with stainless steel has been acknowledged in technical rules for a long time. However, the direct transition point to other systems is not explicitly regulated by the manufacturer's warranty guidelines of stainless steel system suppliers.

REHAU recommends the system pressing adapters RAUTITAN SX and RAUTITAN SX system adapters with male threads (both in stainless steel) for direct system connections to stainless steel installation systems.

The same fitting directions apply for the RAUTITAN SX system pressing adapters as for the RAUTITAN RX+ soldering/pressing adapters.

Transition to stainless steel systems



Fig. 41-20 System adapter with stainless steel RAUTITAN SX male thread and stainless steel RAUTITAN SX system pressing adapter

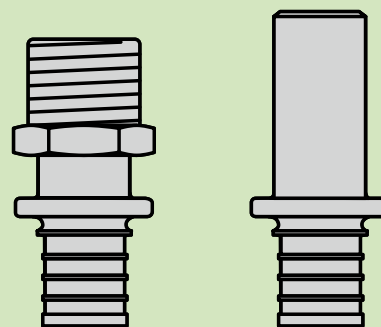

Fig. 41-21 System adapter with stainless steel RAUTITAN SX male thread and stainless steel RAUTITAN SX



System adapter made of stainless steel

- To connect installation systems made of stainless steel, only use the system pressing adapters RAUTITAN SX and system adapters with male threads RAUTITAN SX, both in stainless steel.
- The system pressing adapters are available for metal compression system made of stainless steel with radial compression joints according to DVGW worksheet W 534).
- Do not confound the RAUTITAN SX fittings with the fittings with silver surfaces, which are used to connect the heating pipe RAUTHERM S (underfloor heating/cooling).
- Please note the measurements of the fittings.

Threaded fittings made of stainless steel

- Do not use sealing tape or sealants (e.g. Teflon) which release chloride ions soluble in water.
- Use sealants which do not release chloride ions soluble in water (e.g. hemp).
- To avoid a crevice corrosion of the fittings RAUTITAN SX we recommend the use of hemp as thread sealant.

If the RAUTITAN system is connected to other systems made of stainless steel by interconnecting fittings (e.g. flush-mounted valves or water meters), it is unnecessary to use the RAUTITAN SX adapters.

The material combination of brass with stainless steel has been acknowledged in technical rules for a long time. However, the direct transition point to other systems is not explicitly regulated by the manufacturer's warranty guidelines of stainless steel system suppliers.

To avoid a loss of warranty for the user of the REHAU system, uniform materials must be used at the system transition to stainless steel systems.

REHAU specifies only the system pressing adapters RAUTITAN SX and RAUTITAN SX system adapters with male threads (both in stainless steel) for direct system connections to stainless steel installation systems.

The same fitting directions apply for the RAUTITAN SX system pressing adapters as for the RAUTITAN RX+ soldering/pressing adapters.

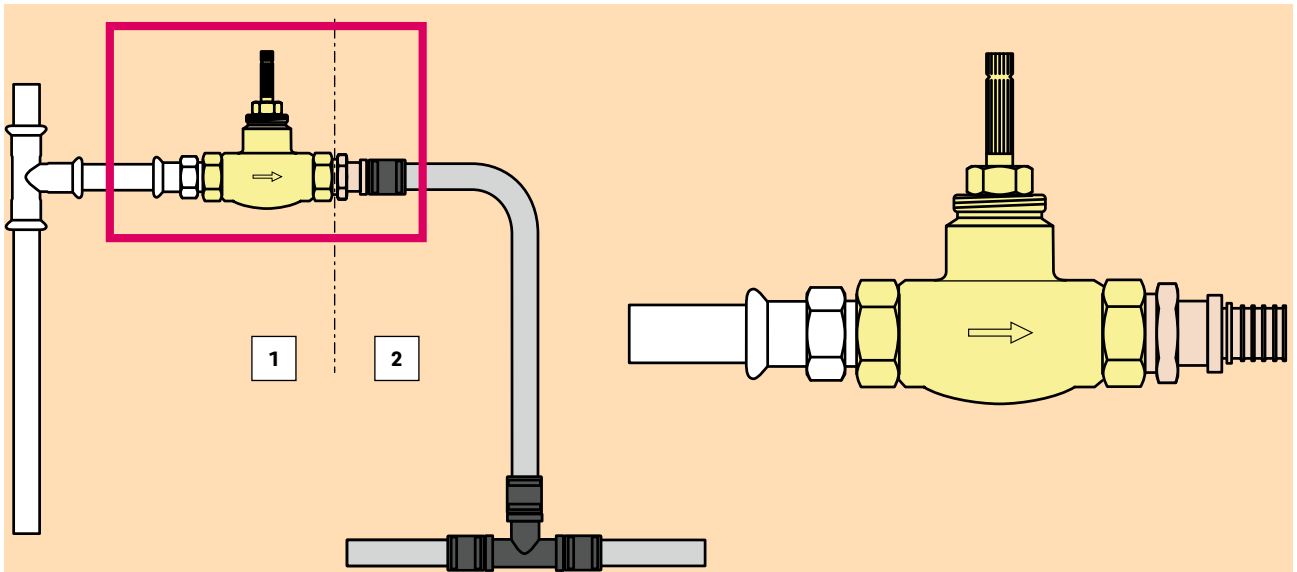

Fig. 41-22 Installation situation of a system adapter to a flush mounted valve (example)

- 1 Stainless steel system with flush-mounted valve
- 2 RAUTITAN system with RAUTITAN RX+ thread adapters

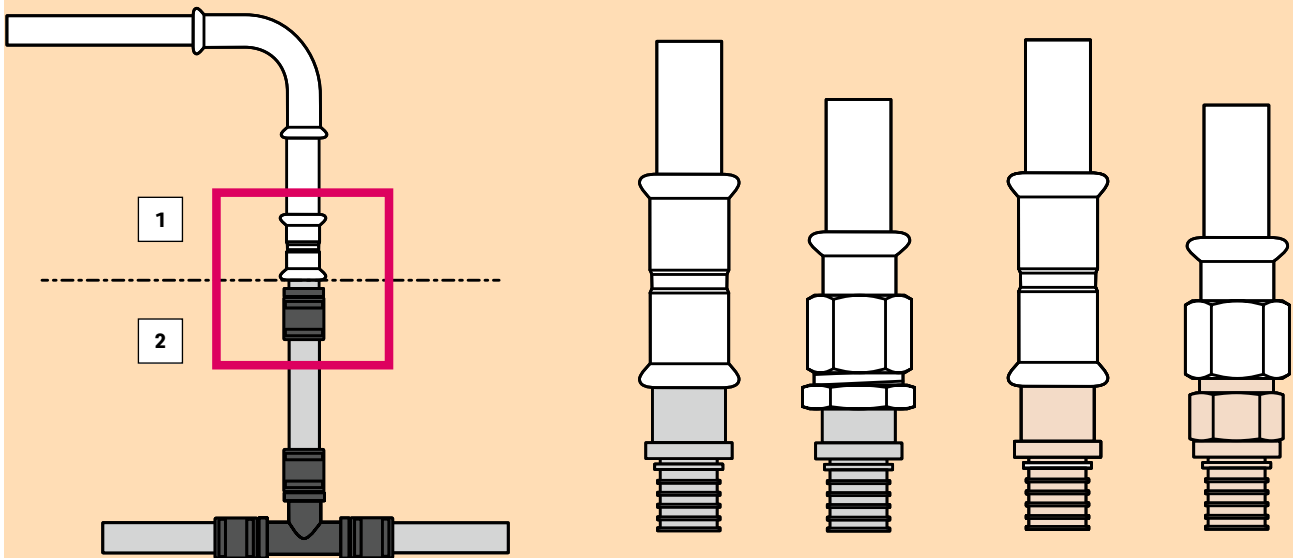

Fig. 41-23 Direct transition from stainless steel systems to the RAUTITAN system up to size 32 or with threads up to R1/Rp1

- 1 Stainless steel system
- 2 RAUTITAN system with RAUTITAN SX adapters (stainless steel) and RAUTITAN RX+ (gunmetal)

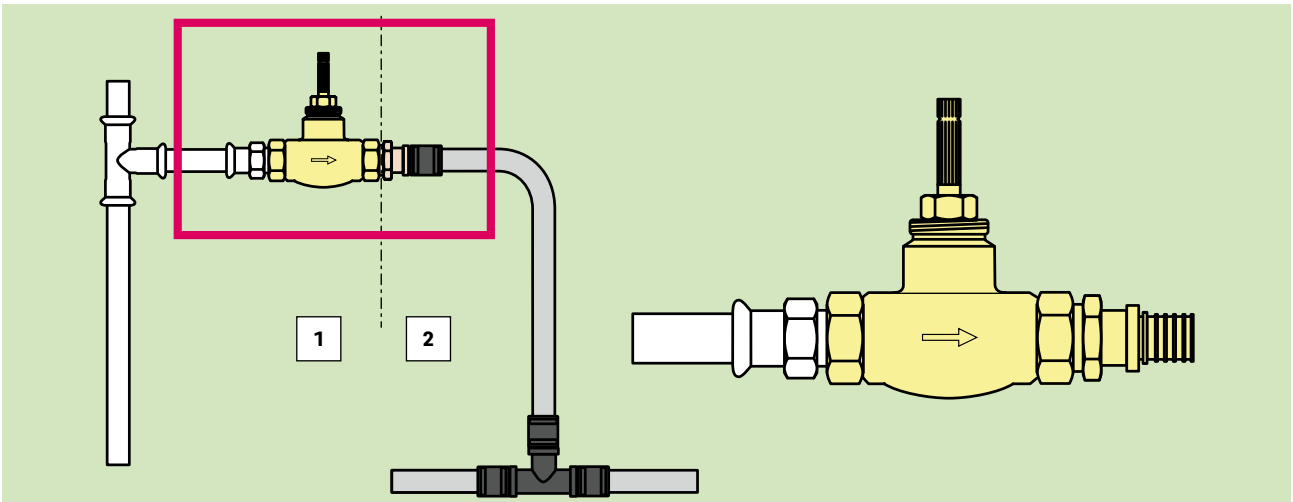

Fig. 41-24 Installation situation of a system adapter to a flush mounted valve (example)

- 1 Stainless steel system with flush-mounted valve
- 2 RAUTITAN system with RAUTITAN LX thread adapters (brass)

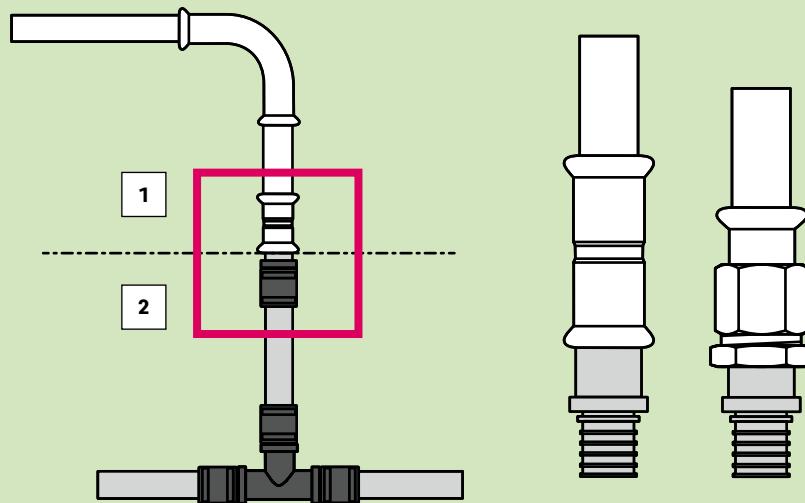

Fig. 41-25 Direct transition from stainless steel systems to the RAUTITAN system up to size 32 or with threads up to R1/Rp1 in stainless steel (example)

- 1 Stainless steel system
- 2 RAUTITAN system with RAUTITAN SX adapters (stainless steel)

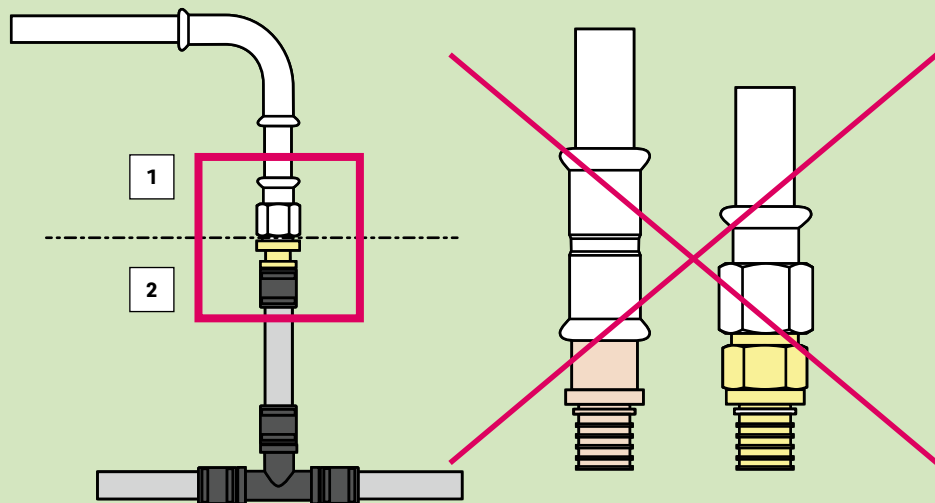

Fig. 41-26 No direct transition from stainless steel systems to the RAUTITAN system up to size 32 or with threads up to R1/Rp1

- 1 Stainless steel system
- 2 RAUTITAN system with RAUTITAN LX adapters (brass) and RAUTITAN RX+ (gunmetal)

41.05 Connection to fittings



Fig. 41-27 Adapter with RAUTITAN union nut

Equipment and fittings can be easily connected by using adapters with union nuts.



The pipe and the thread nominal diameter has to be considered to choose an appropriate connector.

For example:

Connector 20 - G $\frac{3}{4}$ is appropriate for a valve DN 15 with an male thread G $\frac{3}{4}$.

41.06 Installation notes for connection components and valves



Laying temperature

- Do not go below the minimum laying temperature of $-10\text{ }^{\circ}\text{C}$.
- Do not exceed the maximum laying temperature of $+50\text{ }^{\circ}\text{C}$.

- Do not use dirty or damaged system components, pipes, fittings, compression sleeves or seals.
- Make sure that the connection components are free of inadmissible stress during assembly and in operation. Make sure that the piping has sufficient scope of movement (e.g. from deflection legs).
- Do not clamp fitting too tightly into the vice.
- Using pipe wrenches can cause damage to the fittings and compression sleeves.
- Install screw connections and fittings in an accessible manner and carry out regular inspection and maintenance. Check infrequently used valves for leaks after they have been operated.

Aligning the fittings

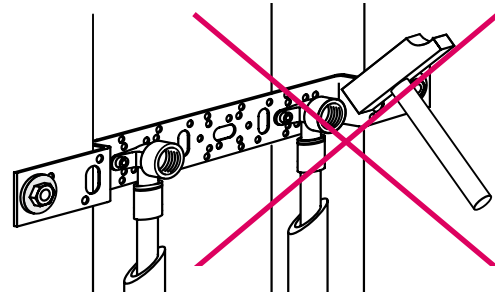

Fig. 41-28 Do not align using a hammer

- Do not subject fittings and compression sleeves to plastic deformation, e.g. by hammer blows.
- Only align fittings with suitable tools, e.g. pipe nipples or open-end wrenches.

Threaded fittings

The threads of fittings with thread adapters are executed as follows:

- Thread according to ISO 7-1 and DIN EN 10226-1:
 - Rp = cylindrical female thread
 - R = conical male thread
- Thread according to ISO 228:
 - G = cylindrical thread, non-sealing in the thread
- Only use threads according to ISO 7-1, DIN EN 10226-1 and ISO 228 standards. Other thread types are not permitted.
- Check if thread types ISO 7-1 and DIN EN 10226-1 are capable of being combined with the thread typ ISO 228 before screwing them together, e.g. tolerances, free movement. Other thread types are not permitted.
- Only use an appropriate G male connector with flat sealing thread fittings with G female thread.
- If using long threads, ensure the maximum possible screwing depth and sufficient thread depth in opposing parts with inside threads.
- Only use sealants approved for gas and water installation (e.g. DVGW-certified sealants).
- Do not apply excessive hemp to threaded joints. The thread tips must be visible.
- Use open-end wrenches in the right size.
- Avoid overtightening threaded joints.
- Do not extend the leverage of system tools, e.g. with pipes.
- Screw the threaded joints together so that the thread end remains visible.
- When flat-sealed joints (or similar) are opened, check that the sealing surface is undamaged before reconnecting and insert a new seal if necessary.

Protection against corrosion and damage

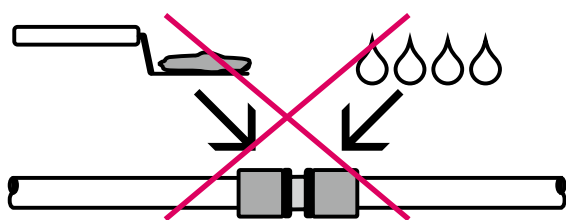

Fig. 41-29 Avoid the risk of corrosion

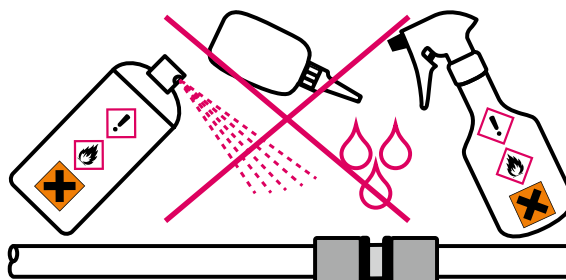

Fig. 41-30 RAUTITAN PX: Avoid contact with lack, liquid thread sealant and tapping oil

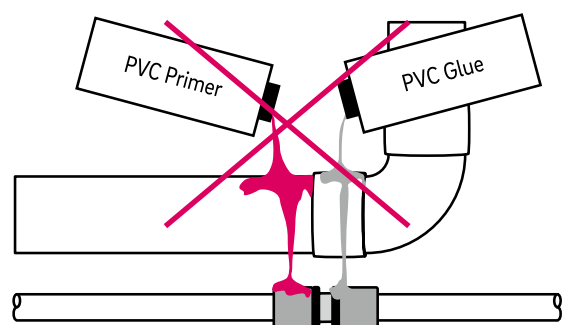

Fig. 41-31 RAUTITAN PX: Avoid contact with glue (e.g. PVC glue)



Fig. 41-32 RAUTITAN PX: Avoid unintentional contact with aggressive substances



Fig. 41-33 Protect connection components against corrosion or aggressive substances



Water additives

The piping can be damaged when using inhibitors, antifreeze agents or other heater water additives. Approval must be obtained from the respective manufacturers and from our Applications Department. In this case, please consult your REHAU sales office.



- Use suitable sheathing to protect fittings and compression sleeves against contact with brickwork or with screed, cement, plaster, bonding agents, aggressive media and other materials and substances which can cause corrosion.
- Protect fittings, pipes and compression sleeves against humidity.
- Ensure that the employed sealants, cleaning agents, building foams, insulation, protective tape, adhesive tape or thread sealant etc. do not contain any components which cause stress cracking or corrosion, e.g. ammonia, ammonia-bearing, aromatic and oxygenated solvents (e.g. ketone and ether), chlorinated hydrocarbons or chloride ions which can leach.
- Protect fittings, pipes and compression sleeves against dirt, drilling dust, primer and glue, mortar, grease, oil, paint, lacquers, adhesive/protective primers, solvents, etc.
- In aggressive environments (e.g. farming, encased in concrete, sea water atmosphere, cleaning agents), protect piping and fittings against corrosion adequately and in such a way that they are sealed against diffusion (e.g. to aggressive gases, fermentation gases, chloride mediums).
- Protect fittings, pipes and compression sleeves against humidity.
- Protect systems against contact to chemicals and damage (e.g. during the construction phase, when in the area of vehicles, machines or farming, and from damage caused by game animals).

**RAUTITAN PX**

- Only use leak detection agents (e.g. foaming agents) with current DVGW registration, which were also approved by the respective manufacturer for the PPSU and PVDF materials.
- Only use sealants, thread sealants, cleaning agents, insulation, protective tape, adhesive tape and flux, which were approved by the respective manufacturer for the materials PPSU and PVDF.
- Avoid the contact with building foams using a suitable product (e.g. protective tape RAUTITAN).
- When using the connection components, check the compatibility of materials for the corresponding area of application.
- Contact with aromatic and oxygenated solvents (e.g. ketone and ether) as well as halogenated hydrocarbons (e.g. chlorinated hydrocarbons) is not permitted.
- Contact with water-based acrylic paints and adhesive/protective primers is not permitted.

RAUTITAN SX

- Do not use sealing tape or sealants (e.g. Teflon) which release chloride ions soluble in water.
 - Use sealants which do not release chloride ions soluble in water (e.g. hemp).
 - To avoid a crevice corrosion of the fittings RAUTITAN SX we recommend the use of hemp as thread sealant.
-

42 System tools RAUTOOL



- Before using tools, fully read and observe the information in the operating instructions.
- If these operating instructions are no longer present with the tool or are no longer available, order a copy or download them in internet.
- Do not use damaged tools or tools limited in their function; send these for repair to your REHAU sales office.
- Only make compression sleeve joints with RAUTOOL tools.

If foreign tools are to be used when making the joint, these must be approved by the corresponding manufacturer for use with the RAUTITAN system and especially for use with the new RAUTITAN PX fittings and compression sleeves.



Operating instructions can be downloaded online from www.rehau.com or www.rehau.com/montagewerkzeuge.



The scope of delivery of the RAUTOOL system tools can be seen from the Building Technology price list.

42.01 Compression sleeve tools RAUTOOL (part of the product program)

The basic tool is suitable for a wide range of applications:

- Plumbings installation with RAUTITAN
- Panel heating and cooling with RAUTHERM S
- Industrial applications with RAUPEX
- Local and district heating supply with RAUTHERMEX and RAUVITHERM



The hydraulic tools RAUTOOL A-light2/A-light, E3/E2 and H2/H1 are compatible with each other and can be equipped with the same supplementary sets.

RAUTOOL A-light2



- Battery hydraulic tool
- Sizes 16 – 40 mm

RAUTOOL Xpand QC



- Battery hydraulic tool with Li-Ion battery
- Sizes 16 – 40 mm
- Easy handling with switch mechanism Expander QC (patented)

RAUTOOL A-one



- Combined battery hydraulic tool and expander with Li-Ion battery
- Sizes 16 – 32 mm
- Not allowed for brass compression sleeve RAUTITAN PX
- With the patented yoke system for the quick change of the slide yoke and expander

RAUTOOL A5



- Compact battery hydraulic tool with Li-Ion battery
- Sizes 40 – 63 (75) mm
- With the patented yoke system for the quick change of the slide yoke and expander

RAUTOOL M1

- Manual tool
- Sizes 16 – 40 mm



Only use the compression jaws M1 with the RAUTOOL M1.

42.02 Pipe shears



- Check the blade of the pipe shears regularly for damage and replace the blade or the shears as necessary. Damaged or blunt blades can cause burrs or notches on the pipe, which can tear when the pipe is expanded.
- Cut off improperly cut pipe ends.
- If cracks occur at the expanded zone, cut off the damaged pipe end and repeat the expanding procedure.

- +When cutting the pipes, observe the following:
- Use the correct pipe shears for the corresponding pipe type only.
 - Cut the pipe square and without burrs.
 - Pipe shears must be in perfect condition.

Spare blades for the pipe shears can be re-ordered (except the pipe shears 25).

Pipe size		16/20	25 to 40	40 to 63
Universal pipe RAUTITAN stabil				
Gas pipe RAUTITAN gas stabil				
		Pipe shears 16/20 RAUTITAN	Pipe shears 40	Roll tube cutter

Rohrabbmessungen		to 20	to 25	to 40	40 to 63
Universal pipe RAUTITAN flex					
		Pipe shears 16/20 RAUTITAN	Pipe shears 25	Pipe shears 40	Roll tube cutter

Tab. 42-1 Selection of pipe shears



RAUTITAN stabil in sizes 50 and 63 can be cut with the pipe shears 63. However, since the use of the pipe shears is difficult and requires a large effort, REHAU recommends the use of a roll tube cutter.

Using the pipe shears 63 to cut RAUTITAN stabil 50 and 63 can cause an oval deformation of the pipe cross-section and thus complicates or prevent further work steps.

42.03 Pipe shears 16/20 RAUTITAN



Fig. 42-1 Cutting a universal pipe RAUTITAN stabil with the pipe shears 16/20 RAUTITAN

For right-angled cutting of the universal pipe RAUTITAN stabil without burrs in sizes 16 and 20.



Only use pipe shears 16/20 RAUTITAN when cutting universal pipe RAUTITAN stabil and gas pipes RAUTITAN gas stabil in sizes 16 and 20.



When using the manifold union, calibrate the universal pipe RAUTITAN stabil (pipe sizes 16 and 20) with the calibrating mandrel moulded onto the side of the pipe shears 16/20 RAUTITAN.



PE-X pipes can also be cut with the pipe shears 16/20 RAUTITAN.



Fig. 42-2 Calibrating mandrel

42.04 Pipe shears 25

To be used exclusively for burr-free cutting of PE-X pipes up to size 25 (see „Tab. 42-1 Selection of pipe shears“)

42.05 Pipe shears 40 stabil

To be used exclusively for burr-free cutting of PE-X-pipes up to size 40 and for RAUTITAN stabil/ RAUTITAN gas stabil in size 25 to size 40 (see „Tab. 42-1 Selection of pipe shears“).

42.06 Roll tube cutter

For burr-free cutting of RAUTITAN stabil pipes 40 to 63.

42.07 Pipe shears 63









For burr-free cutting of RAUTITAN pipes in sizes 40–63 (see „Tab. 42-1 Selection of pipe shears“)

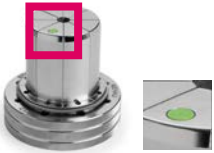

Use a pipe shears 63 with a very sharp and in mint condition blade to cut RAUTITAN stabil 50 and 63.

43 Expanding tools

43.01 Expander heads and expander bits for pipes

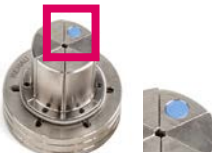
	Expander heads		Expander bits	Expander head for RAUTOOLA5
Rohrabmessungen	16/20/25/32		40	50/63
Universal pipe RAUTITAN stabil <u>stabil</u>				
Gas pipe RAUTITAN gas stabil <u>gas stabil</u>				
Rohrabmessungen	16/20/25/32		40	50/63
Universal pipe RAUTITAN flex <u>flex</u>				

Tab. 43-1 Selection of expanding tools



gas stabil

The processing of the gas pipes RAUTITAN gas stabil with the expander head QC 1 is not permitted.



For processing RAUTITAN flex pipes in sizes 40/50/63 with the RAUTOOL G2 system tool, the expansion heads G are also available.



Expander head for radiator connection sets RAUTITAN



Fig. 43-1 Expander head 15 x 1.0 QC

Expander head for the stainless steel pipes or copper pipes 15 x 1.0 of the radiator connection sets RAUTITAN.

Using the expander head 15 x 1.0 QC is described in chapter „21 Connections with radiator bend“, page 70.

Expander head QC

- Expander head Quick Change with patented bayonet lock
- Expander head for universal pipe RAUTITAN stabil and gas pipe RAUTITAN gas stabil
 - Green color marking
 - Black retaining nut in dim. 16–32
 - 6 expansion segments chamfered
- Expander head for universal pipe RAUTITAN stabil in dim. 50 and 63
 - Green color marking
 - Silver colored retaining nut
 - 8 expansion segments chamfered
- Expander head for universal pipe RAUTITAN flex
 - Blue color marking
 - Silver colored retaining nut in dim. 16–32
 - 6 expanding segments without chamfering
- Expander head 15 x 1.0 for radiator connection sets RAUTITAN
 - No color marking
 - For expanding connection sets made of stainless steel or copper



Expander head QC 1

- Quick Change expander head with patented bayonet lock and 4 toothed segments
- One-step expansion (simplified assembly process)
- Black segments



- Not allowed for RAUTITAN gas pipes.
- Not compatible with brass compression sleeve connections.

- Expander head for universal pipe RAUTITAN stabil
 - Green colour marking
 - Black retaining nut
- Expander head for universal pipe RAUTITAN flex
 - Blue colour marking
 - Silver-coloured retaining nut



Universal expander bit



Fig. 43-2 Universal expander bit

The universal expander bit QC can be used in combination with the suitable expander heads and hydraulic tool to expand RAUTITAN pipes 25 and 32.

43.02 Expander bits

When combined with the RAUTOOL tools A-light2, the following expander bits can be used:

- Universal expander bit 25/32 QC
- Expander bit 40 x 6.0 stabil
- Expander bit 40 x 5.5

Only expand universal pipe RAUTITAN stabil and gas pipe RAUTITAN gas stabil in size 40 with the expander bit 40 x 6.0.

- Expansion only possible with RAUTOOL A-light2.
- Expansion not possible with RAUTOOL G2 and M1.

43.03 Safety advice on the expander heads



- Do not use any defective segments or expander heads (e.g. bent, broken off, broken tooth, fractured).
- Ensure that expansion is even over the entire circumference of the pipe.
- Discard unevenly expanded pipe ends.
- Check the expander head for damage, if necessary carry out test expansion to test even expansion (e.g. no grooves, no local overstretching of the pipe material).
- Replace defective expander head.
- Do not apply grease or similar materials to the expansion segments.
- Apply grease regularly to the cone of the expander.
- Do not use dirty or damaged expander heads, pipes or connection components.
- If cracks occur at the expanded zone or if the pipe ends were not expanded properly, cut off the damaged pipe end, check the blade of the pipe shears for damage and repeat the expanding procedure.
- Observe the allocation of the expander heads to the respective pipe types and sizes.



- Accessories (brush, lubricating grease, etc.) are included in the tool case.
- The universal pipe RAUTITAN flex is equipped with an oxygen diffusion barrier. The oxygen diffusion barrier is not always as flexible as the crosslinked polyethylene base pipe. It could thus happen that the diffusion barrier tears slightly when the pipe is expanded at low temperatures. These tears do not have an effect on the pipe's performance and have no effect on the reliability of the compression sleeve joint. As the tears are located at the compression sleeve joint and are enclosed at both sides with the fitting or compression sleeve and they have no notable effect on the oxygen-tightness as specified in DIN 4726.

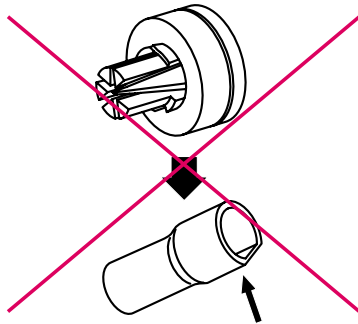

Fig. 43-3 Damage to the piping material by defective expander head

44 Making the compression sleeve joint

44.01 Important advices



A precise direction for tool handling and processing the joint are described in the respective operating instructions.

On the following pages, the connection technology with the compression sleeve from REHAU is shown as an example for the dimensions 16 – 32 with RAUTOOL A-light or 50 – 63 with RAUTOOL A5.



Close to the minimum laying temperature (–10 °C) we recommend using the system tools RAUTOOL with hydraulic force transmission to simplify installation.



Operating instructions can be downloaded online from www.rehau.com or www.rehau.com/montagewerkzeuge.



- Only make compression sleeve joints with RAUTOOL tools.
If foreign tools are to be used when making the joint, these must be approved by the corresponding manufacturer for use with the RAUTITAN system and especially for use with the new RAUTITAN PX fittings and compression sleeves.
- Only make the joint with the appropriate system tools.
- Please consult the Technical Information and corresponding operating instructions and instruction leaflets for information on handling the tools and making joints.
- Do not use dirty or damaged connection components or tools.
- The battery and mains operated tools like A-light 2, A3, E3, G2 are not suitable for permanent operation. After approx. 50 consecutive clamping operations, a break of at least 15 min. is required to allow the tool to cool down.
- The exact assignment of the connection components can be found in the current price list.

Laying temperature

- Do not go below the minimum laying temperature of –10 °C.
- Do not exceed the maximum laying temperature of +50 °C.

44.02 Processing the compression sleeve joint sizes 16 to 40

Cutting the pipe



The universal pipe RAUTITAN stabil 40 x 6.0 and the gas pipe RAUTITAN gas stabil 40 x 6.0 have shorter expansion lengths than the other RAUTITAN pipes in size 40.

When correctly expanded and pushed fully on, the expanded pipe section ends approx. 6 mm before the collar of the fitting.

Here, each Z-measurement extends by 4 mm. The entire pipe length, which is to be cut off, thus reduces by approx. 8 mm.

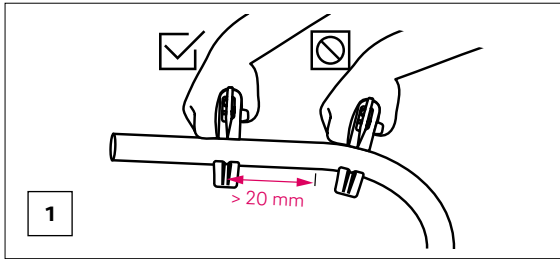

Use pipes free from any pollution (e.g. lubricant, adhesive or adhesive tape).

Pushing the compression sleeve over the pipe

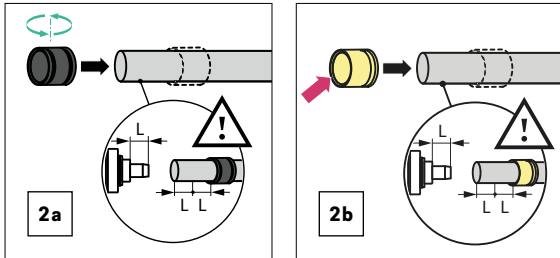

Check the compression direction of the compression sleeve:
The inner socket points towards the fitting.

Expanding the pipe with the expander



- Follow the safety advice for the expander heads (see page 176).
- Check the expander heads for freedom of movement and dirt and clean, if necessary.
- Screw the expander heads fully onto the expansion tool or latch completely onto the bayonet (must not become detached when twisted in pipe).
- Expand the pipe when cold.
- If cracks occur at the expanded zone or if the pipe ends were not expanded properly, cut off the damaged pipe end and repeat the expanding procedure.

- The pipe to be expanded must have an even temperature. Avoid local heating (e.g. by inspection lamps, etc.).
- Expand the pipe when cold and stress-free.
- Always push the segments of the expander head fully into the pipe.
- Avoid skewing the expander head.

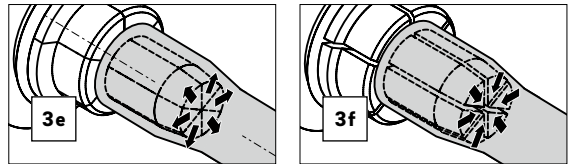
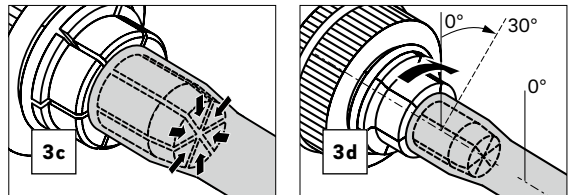
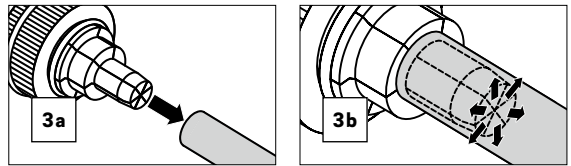

With expander head QC 1 the pipe shall only be expanded once.



Inserting the fitting into the expanded pipe

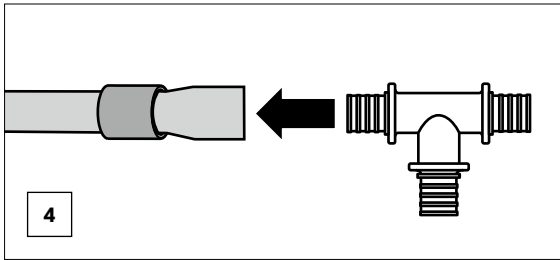

- When the pipe has been correctly expanded, the fitting can be pushed into the expanded pipe without difficulty.
- After a short time, the fitting is held firmly in the pipe, as the pipe contracts (memory effect).
- Handle joints which are not clamped when inserting them into the tool and during clamping so that they cannot fall apart.
- All sealing ribs must be covered by the pipe, as shown in Tab. 44-1 and Tab. 44-2. A possible distance of < approx. 1 mm to the pre-stop or to the collar may occur due to tolerances. An exception is when pushing the universal pipe RAUTITAN stabil onto the RAUTITAN PX fittings, size 40. Here, the last sealing rib may not be fully covered.

Inserting the joint into the clamping tool

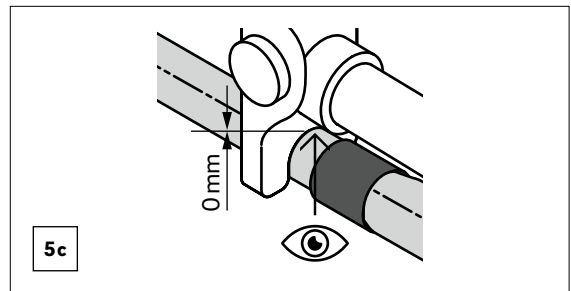
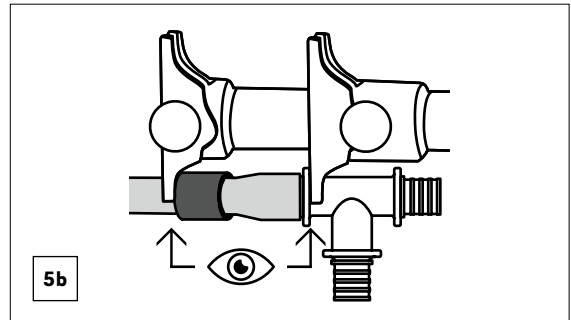
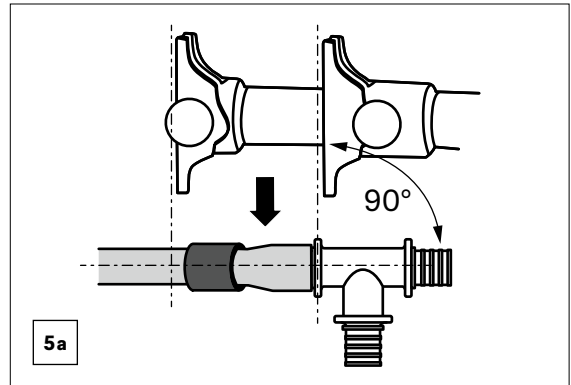

Correct position of the pipe on the RAUTITAN PX fitting

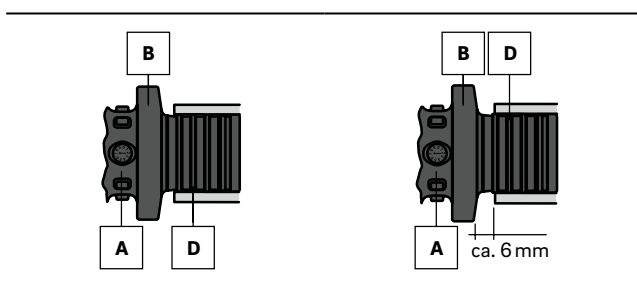

Tab. 44-1 Correct position of the pipe on the PX fitting

Correct position of the pipe on metal fittings

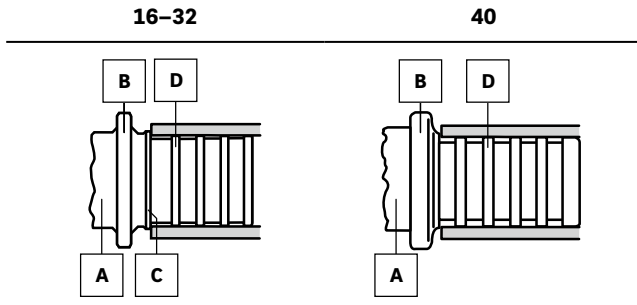

Tab. 44-2 Correct position of the pipe on metal fittings

- | | |
|-------------------------|----------------------|
| A Fitting body | C End collar |
| B Fitting collar | D Sealing rib |

Pushing the compression sleeve up to the fitting collar

- Operate the pressure switch on the tool until the tool automatically ends the pressing process.
- Carry out an optical check of the joint for damages and incomplete insertion of the compression sleeve.



- Bulging of the metal compression sleeve does not impair the quality of the joint and usually occurs when older expander heads are used.
- During the connection process an additional accumulation of the pipe material can occur. In this case, stop pushing on the brass compression sleeve shortly before the bulge (approx. 2 mm distance to the fitting collar).

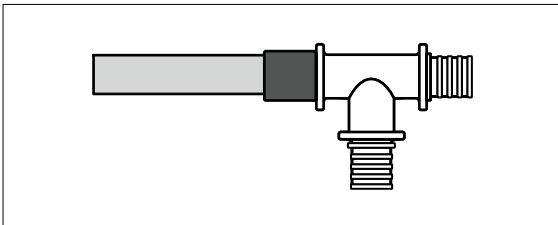
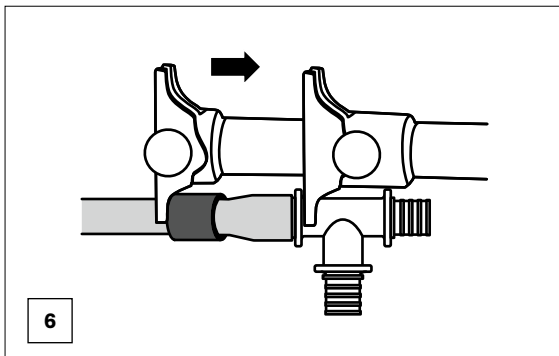

44.03 Processing the compression sleeve connection with RAUTITAN 50 and 63

Cutting the pipe

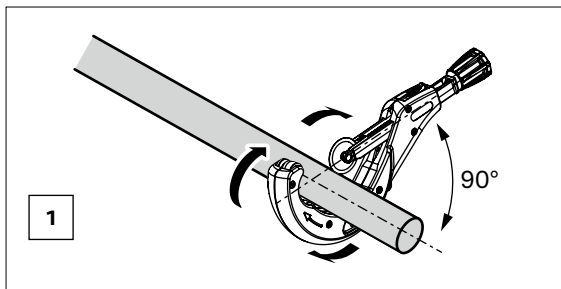

Use pipes free from any pollution (e.g. lubricant, adhesive or adhesive tape).

Pushing the compression sleeve over the pipe

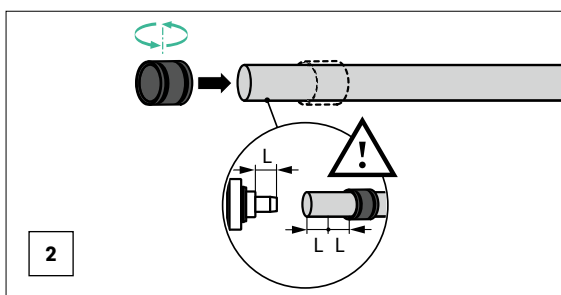

Expanding the pipe with the expander



- Follow the safety advice for the expander heads (see page 176).
- Check the expander heads for freedom of movement and dirt and clean, if necessary.
- Screw the expander heads fully onto the expansion tool (must not become detached when twisted in pipe).
- Expand the pipe when cold.
- If cracks occur at the expanded zone or if the pipe ends were not expanded properly, cut off the damaged pipe end and repeat the expanding procedure.

- The pipe to be expanded must have an even temperature. Avoid local heating (e.g. by inspection lamps, etc.).
- Expand the pipe when cold and stress-free.
- Always push the segments of the expander head fully into the pipe.
- Avoid skewing the expander head.

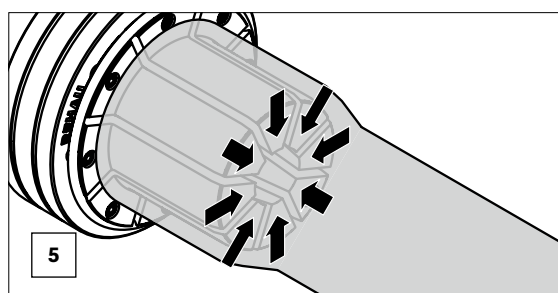
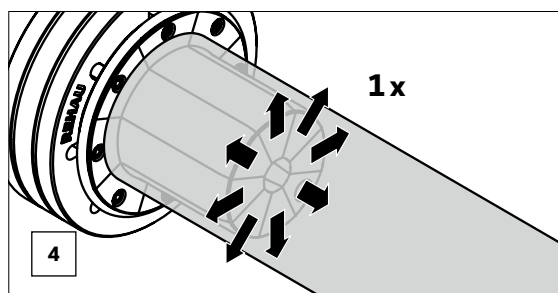
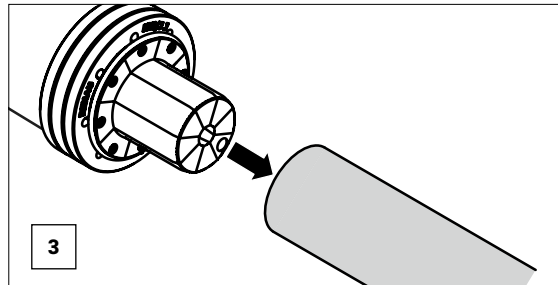

Inserting the fitting into the expanded pipe

- When the pipe has been correctly expanded, the fitting can be pushed into the expanded pipe without difficulty.
- After a short time, the fitting is held firmly in the pipe, as the pipe contracts (memory effect).
- Handle joints which are not clamped when inserting them into the tool and during clamping so that they cannot fall apart.
- All sealing ribs must be covered by the pipe, as shown in Tab. 44-1 and Tab. 44-2. An exception is when pushing the universal pipe RAUTITAN stabil onto the RAUTITAN PX fittings, size 40. Here, the last sealing rib may not be fully covered.

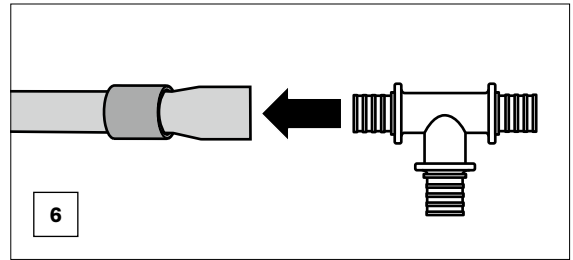

Correct position of the pipe on metal fittings

Size

50-63

Universal pipe RAUTITAN stabil stabil

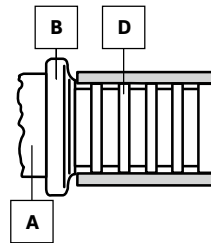

Tab. 44-3 Correct position of the pipe on the fitting

- A Fitting body B Fitting collar D Sealing rib

Inserting the joint into the clamping tool

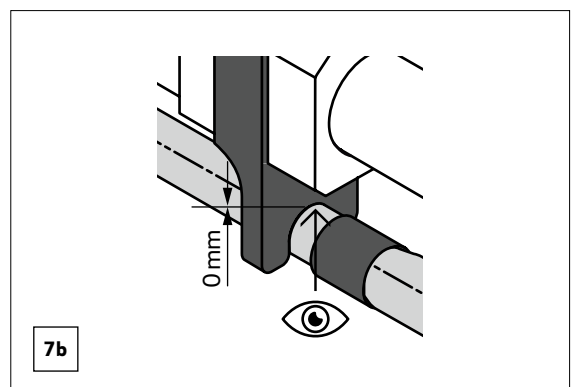
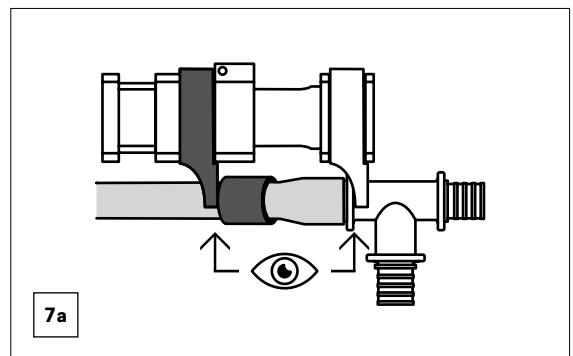
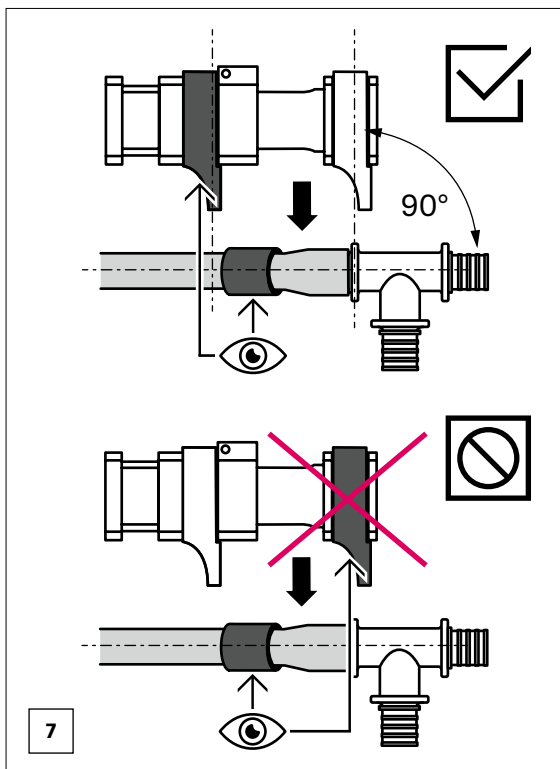

Pushing the compression sleeve up to the fitting collar

- Operate the pressure switch on the tool until the tool automatically ends the pressing process.
- Carry out an optical check of the joint for damage and incomplete insertion of the compression sleeve.

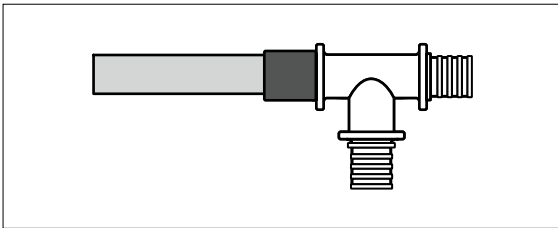
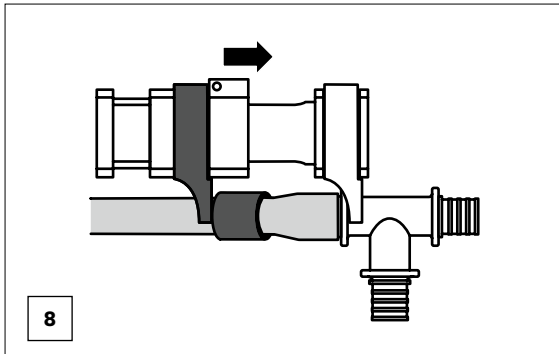

45 Detaching the compression sleeve joint



REHAU will not accept liability if these instructions are not followed (e.g. when heating up the compression sleeve joint when attached).

45.01 Cutting out the joint

Cut the joint to be detached completely out of the existing piping using the pipe shears or the roll tube cutter. Maintain a safe distance between the holding hand and the pipe shears.

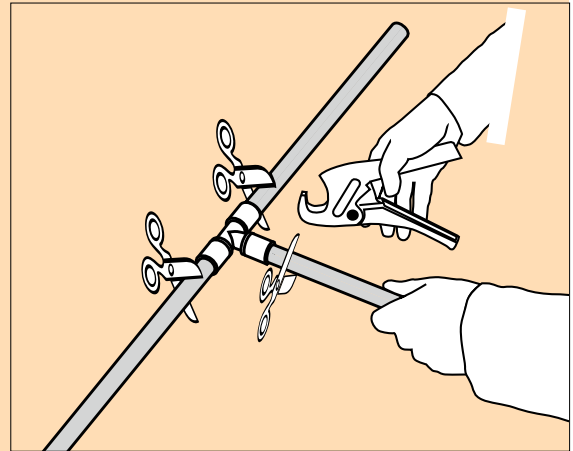

Fig. 45-1 Cutting out the joint

45.02 Usability of cut-out joints

Usability of the parts of a detached compression sleeve joint

Reusable

RAUTITAN system

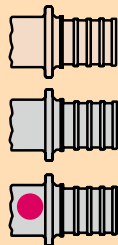

Not reusable

Dispose of together with all cut-out pipe parts

Compression sleeves

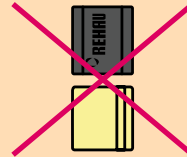

Fittings
RAUTITAN PX



Tab. 45-1 Usability of detached compression sleeve joints



Removed metal fittings from gas installations

- Already processed connection components from gas installations should not be reused or detached.
- Dispose of cut-out connection components.



Removed fittings from water installations

- Immediately dispose of used RAUTITAN PX fittings and RAUTITAN PX compression sleeves after their marking as unusable or their distinctively destroying.
- Only reuse removed metal fittings in perfect condition within the same installation type from which they were removed.
- Removed metal fittings from water installations should not be used in gas installations either, if the installation has a yellow marking on it.
- Dispose of the detached compression sleeves with the detached pipe sections after their marking as unusable or their distinctively destroying.

46 Detaching the compression sleeve joint



REHAU will not accept liability if these instructions are not followed (e.g. when heating up the compression sleeve joint when attached).

46.01 Cutting out the joint

Cut the joint to be detached completely out of the existing piping using the pipe shears or the roll tube cutter. Maintain a safe distance between the holding hand and the pipe shears.

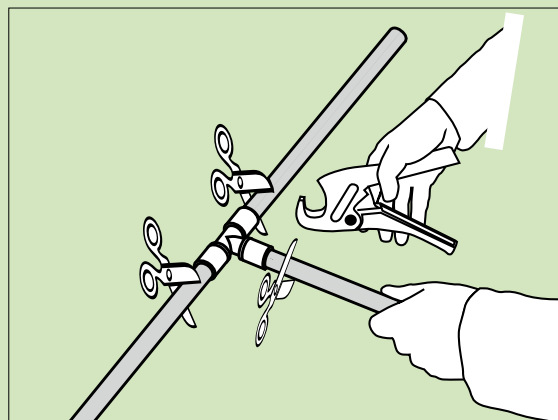

Fig. 46-1 Cutting out the joint

46.02 Usability of cut-out joints

Usability of the parts of a detached compression sleeve joint

Reusable

RAUTITAN system

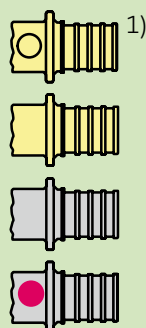

Not reusable

Dispose of together with all cut-out pipe parts

Compression sleeves

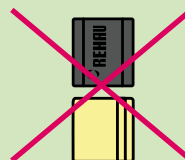

Fittings RAUTITAN PX



Fittings RAUTITAN LX +G in gas installations

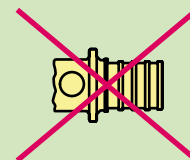

1) only from drinking water installations and heating installations
Tab. 46-1 Usability of detached compression sleeve joints



Removed metal fittings from gas installations

- Already processed connection components from gas installations should not be reused or detached.
- Dispose of cut-out connection components.

Removed fittings from water installations

- Immediately dispose of used RAUTITAN PX fittings and RAUTITAN PX compression sleeves after their marking as unusable or their distinctively destroying.

- Only reuse removed metal fittings in perfect condition within the same installation type from which they were removed.
- Removed metal fittings from water installations should not be used in gas installations either, if the installation has a yellow marking on it.
- Dispose of the detached compression sleeves with the detached pipe sections after their marking as unusable or their distinctively destroying.

46.03 Detaching the cut-out joint from drinking water and heating installations

46.03.01 Heating the joint to be detached



Heating up the RAUTITAN PX compression sleeves to over 200 °C or direct flame exposure can lead to a build-up of toxic gases.

- Do not heat RAUTITAN PX compression sleeves to over 200 °C.
- It is not permitted to burn or apply a flame to the RAUTITAN PX compression sleeves.

1. Heat up the cut-out metal fitting with a hot air blower. Observe the safety advice in the operating instructions of the hot air blower.
2. On reaching a temperature of approx. 135 °C remove the compression sleeve from the fitting body (e.g. with pliers).

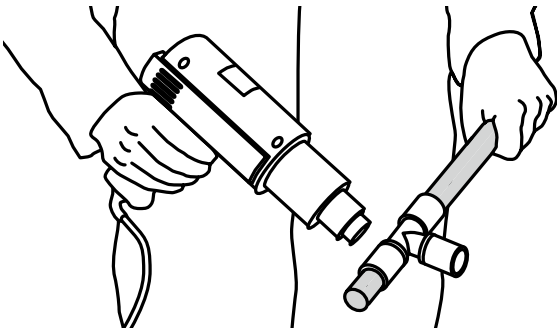

Fig. 46-2 Heating up the joint which is to be detached

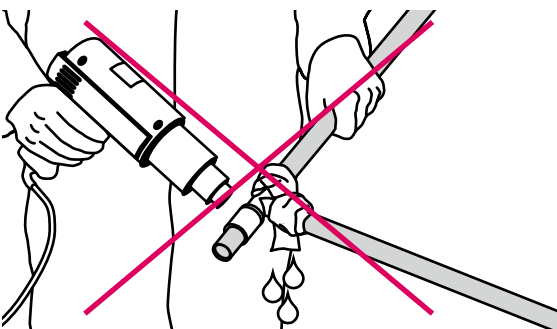

Fig. 46-3 Inadmissible actions



When the joint to be detached is heated, all joints of the heated fitting are no longer sealed.

Always separate the fitting to be heated completely from the piping!

46.03.02 Pulling off the compression sleeves

1. Remove pipe from fitting body.
2. Clean dirt from metal fitting.
 - When in perfect condition and cooled, the metal fitting can be reused.
 - Do not reuse detached compression sleeves and pipe sections.
3. Dispose of the compression sleeves with the detached pipe sections.

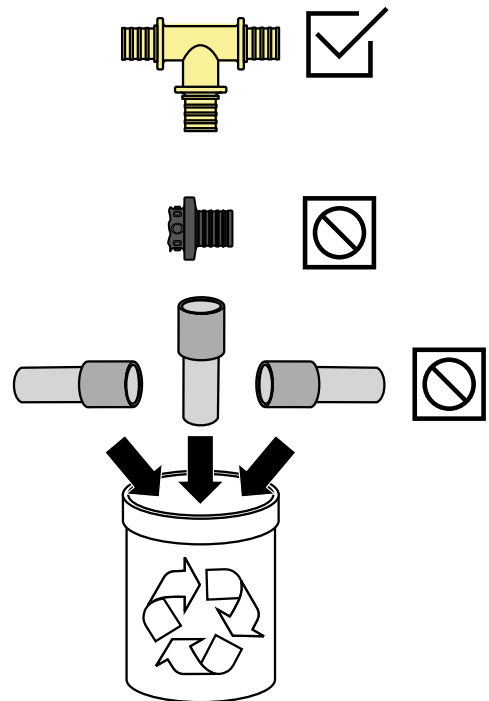

Fig. 46-4 Dispose of the compression sleeves with the detached pipe sections



Detaching Fittings 50 and 63

Due to the large pipe wall thickness fittings in sizes 50 and 63 can only be removed with a consistent effort. The risk of deforming or damaging them during this process is therefore high.

Check detached fittings accurately for damage before re-use them.

47 Bending the pipes

47.01 Bending the universal pipe RAUTITAN stabil and gas pipe RAUTITAN gas stabil



Fig. 47-1 Bent universal pipes RAUTITAN stabil

The universal pipe RAUTITAN stabil and the gas pipe RAUTITAN gas stabil can be bent either by hand or by using a bending tool..

Minimum bending radius

- When bending without tools, the minimum bending radius is five times the outside pipe diameter.
- When bending with a spiral spring, the minimum bending radius is three times the outside pipe diameter.
- The minimum bending radius is in relation to the centre of the pipe.
- Make sure to comply with the specified minimum bending radii.
- After bending, ensure that there are no impressions, wrinkles or bulges and that the outer PE layer and aluminium layer are undamaged.



At laying temperatures under 0 °C, pipe elbows must be over-bent more strongly.

Only cold bending of pipes RAUTITAN stabil and RAUTITAN gas stabil is allowed.

Pipe sizes	with bending tool (90°) 3 x d		bent by hand (90°) 5 x d	
	Bending radius R [mm]	Arc B [mm]	Bending radius R [mm]	Arc B [mm]
16	48.6	76	81	127
20	60	94	100	157
25	75	118	125	196
32	96	151	160	251
40	120	188	–	–
50	150	236	–	–
63	189	297	–	–

Tab. 47-1 Minimum bending radii of universal pipe RAUTITAN stabil and gas pipe RAUTITAN gas stabil

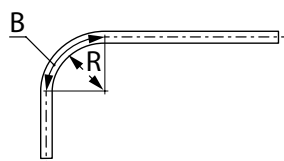

Fig. 47-2 Bending radius and arc

R Bending radius

B Arc

Approved bending tools for universal pipe RAUTITAN stabil and gas pipe RAUTITAN gas stabil

	stabil	gas stabil			
Pipe size [mm]	Source Manufacturer		Model description	Material	Article number
16/20	See price list		Internal spiral spring 16 stabil Internal spiral spring 20 stabil	12474841001 12474941001	247484-001 247494-001
16/20/25	Roller, D-71332 Waiblingen		Roller Polo	153022	
16/20/25	CML Deutschland, D-73655 Plüderhausen		Ercolina Junior	0130G	
16/20/25	REMS, D-71332 Waiblingen		REMS Swing	153022	
16/20/25/32	Tinsel, D-73614 Schorndorf		OB 85	-	
16/20/25/32/40	CML Deutschland, D-73655 Plüderhausen		Ercolina Jolly	0101	
40	REMS, D-71332 Waiblingen		Curvo	580025	
40	Tinsel, D-73614 Schorndorf		UNI 42	-	
40/50/63	Rothenberger, D-69779 Kelkheim		Robull MSR	5.7900	
40/50/63	REMS, D-71332 Waiblingen		Phyton V	59022 R	

Tab. 47-2 Approved bending tools for the universal pipe RAUTITAN stabil and gas pipe RAUTITAN gas stabil (as of: 2015)

47.02 Bending the universal pipe RAUTITAN flex

flex



Fig. 47-3 Pipe bend bracket, plumbing (3-4 x d) - 90° or 45° for size 16-32



Fig. 47-4 Pipe bend bracket, plumbing/heating (5 x d) - 90° for size 16- 25



Fig. 47-5 Pipe bend bracket, plumbing (4 x d) - 90° and pipe bend bracket, plumbing/heating (5 x d) - 90° each in size 32



Hot bending of universal pipes RAUTITAN flex can damage the oxygen diffusion barrier.

Only bend universal pipes RAUTITAN flex when cold.



Using elbows is not always required for sizes between 16 and 32. With pipe bend brackets, 90° and 45° elbows can be cold-bent quickly and easily. For pipe sizes 40 to 63, we recommend using fittings.

Minimum bending radius

When bending by hand, the minimum bending radius

Achtung: Die erweiterte Materialnummer gilt für alle SAP-Länder

is eight times the outside pipe diameter.

When laying with pipe bend brackets, the minimum bending radius in plumbing installations is three times and for heating installations five times the outside pipe diameter.

The minimum bending radius is in relation to the centre of the pipe.

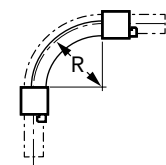

Fig. 47-6 Pipe bend bracket, plumbing 90 degrees, for size 16– 32 and pipe bend bracket plumbing/heating 5 x d 90 degree for size 32

R Bending radius

Pipe	Drinking water installation with pipe bend bracket plumbing 90°, approx. 3–4 x d		Drinking water and heating installation with pipe bend bracket plumbing/heating 90°, 5 x d		Bend by hand (90°) 8 x d	
	flex		flex		flex	
Pipe sizes	Bending radius R [mm]	Arc B [mm]	Bending radius R [mm]	Arc B [mm]	Bending radius R [mm]	Arc B [mm]
16	48	75	80	126	128	201
20	60	94	100	157	160	251
25	75	118	125	196	200	314
32	112	176	160	251	256	402

Tab. 47-3 Minimum bending radii for RAU-PE-Xa pipes

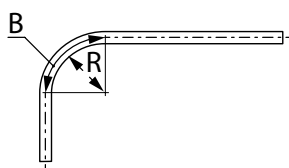

Fig. 47-7 Bending radius and arc

R Bending radius

B Arc

48 Pipe support channel

48.01 Benefits of using the pipe support channel

flex



- Reduces thermal changes in length
- Clip effect increases the axial retaining force
- Stabilises pipes against sagging and sideways bending
- Increases rigidity
- Increases the pipe clamp interval to 2 m regardless of the pipe size
- Visually attractive installations in exposed areas
- Simple assembly
- Self-supporting
 - Is clipped onto the pipe
 - No additional fastenings (e.g. cable ties, insulating tape) required
- Offcuts of pipe support channels can be used
- For special installation situations (e.g. reinforcement of bending stiffness) use with RAUTITAN stabil or RAUTITAN gas stabil pipes possible.

48.02 Functionality

The pipe support channel encloses the pipe by about 60 % and is shaped to closely encase the pipe without additional fastenings. This strong clamping effect prevents the pipe from bending and reduces thermal changes in length.

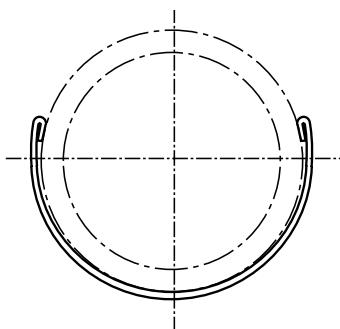

Fig. 48-1 Cross-section of pipe support channel

48.03 Assembly of the pipe support channel

Do not fit pipe support channels or pipe fasteners close to deflection legs to avoid preventing the piping from bending.

Pipe cover

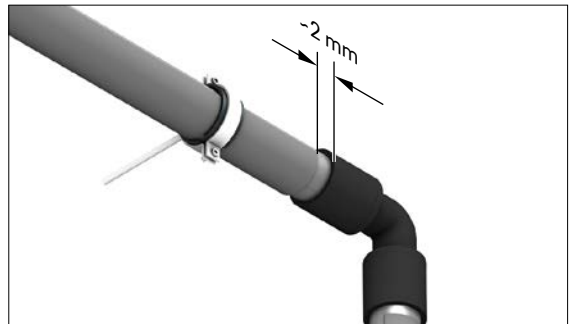

Fig. 48-2 Let the pipe support channel end approx. 2 mm before the compression sleeve

The pipe support channel must be fitted over the entire length of the piping up to 2 mm before the compression sleeve, as only this ensures reduction of the thermal change in length.

Pipe clamp intervals

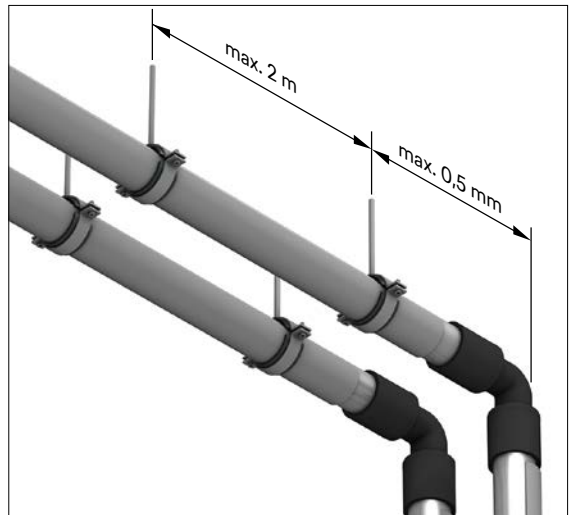

Fig. 48-3 Maximum pipe clamp intervals

The maximum pipe clamp interval when using the pipe support channel is 2 m for all sizes. The distance from the pipe end, or when changing the direction, to the first pipe fastener may not exceed 0.5 m. This way, pipe fastenings for pipe routing or in cellars can be attached in a uniform and rational manner.

Fitting cover

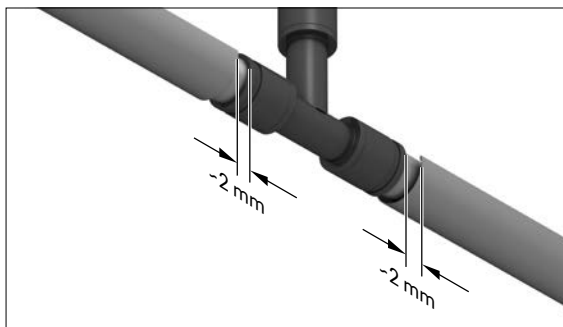

Fig. 48-4 Do not clip over RAUTITAN PX compression sleeves

When using RAUTITAN PX compression sleeves, clipping over the fittings is not possible.

Assembly of the pipe support channels

Reduced retaining force of the pipe support channel can cause greater thermal linear expansion of the pipe.

Do not lessen the retaining force of the pipe support channels by storing or assembling them improperly.

1. Cut off the pipe support channel with a metal saw (see Fig. 48-5). Maintain a safe distance between the holding hand and the cutting tool. Saw pipe support channels from the rounded rear side so that they are not bent open at their bordered ends.

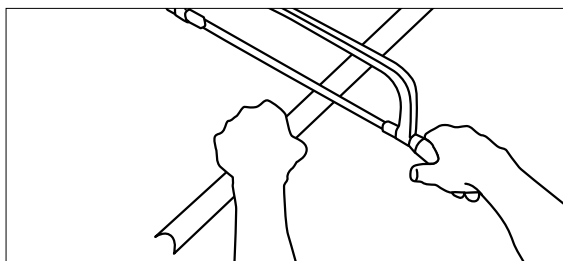

Fig. 48-5 Cutting off

2. If the pipe support channel has been bent inwards or outwards when it was cut to length, bend the pipe support channel back to its original shape.
3. Deburr the ends of the pipe support channel.

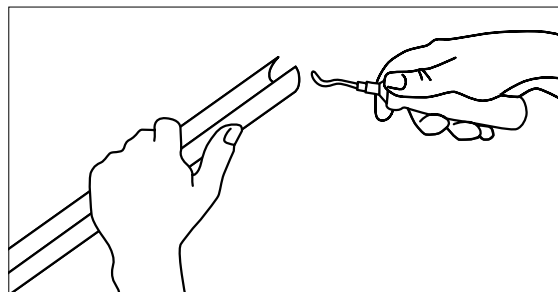

Fig. 48-6 Deburring

4. Clip the pipe support channel onto the pipe (by hand or using a pump or pipe wrench with plastic jaws). Do not overlap the pipe support channels when laying.

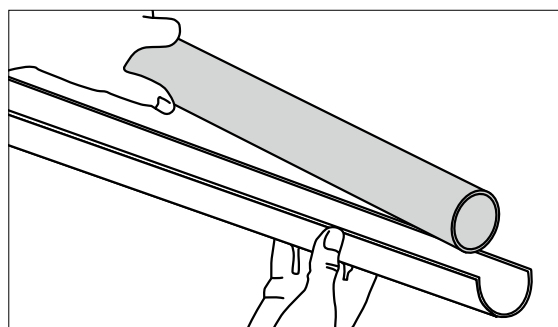

Fig. 48-7 Clipping in

5. Clip offcuts over the joints of the pipe support channels.

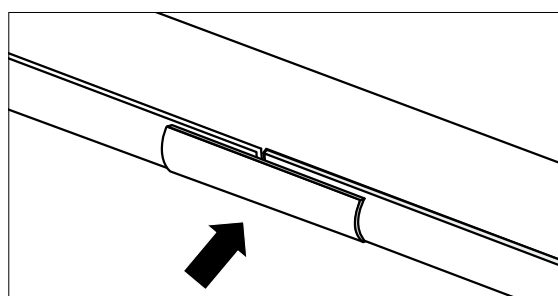

Fig. 48-8 Clipping over

Even short offcuts of the pipe support channel are suitable for clipping over joints and installation almost without cutting losses is possible.

49 Pipe fastening



- Observe the information from the manufacturer of the fastenings.
- The approximate values for the design and execution of the pipe fastenings (see Tab. 49-1) must be adapted to the circumstances in the building and the specifications of the manufacturers of the fastenings as necessary.
- For installation of pipes made of RAU-PE-Xa without pipe support channel, sagging of the piping must be anticipated.
- Fixed points can be used to direct thermal changes in length in a desired direction.
- Longer lengths of piping can be subdivided into individual sections with fixed points.
- Fixed points can be made at tees, elbows or connectors. A pipe clamp is placed directly in front of each compression sleeve of the fitting for this purpose.

49.01 Pipe clamps

Use only pipe clamps with the following properties:

- Suitable for plastic pipes
- Acoustically insulating pipe clamp inserts
- Matching size (for even sliding when installed and to prevent the pipe clamp inserts from pulling out)
- Free of burrs

49.02 Fixed point installation

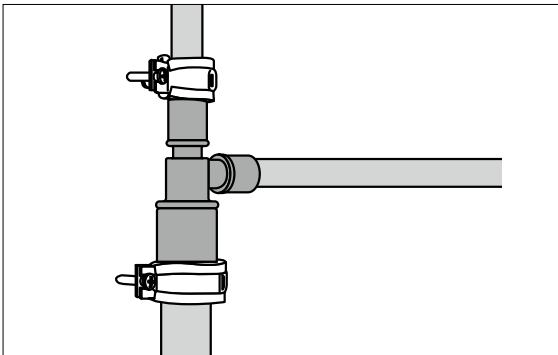

Fig. 49-1 Fixed point made with pipe clamps



Do not install pipe clamps on the compression sleeves.

49.03 Pipe clamp intervals

Choose pipe clamp intervals according to the approximate values (see Tab. 49-1, page 193) for installation with or without pipe support channels.

For vertical pipes clamp intervals can be larger. We recommend at least 2 pipe clamps in each floor.

The guide values of the pipe clamp distances are related to the applications of RAUTITAN pipes (reasons: e.g. installation situations, design temperatures, or tolerated sag) and may deviate from recommendations for other REHAU systems.

49.04 Laying in visible areas

When laying piping in visible areas or long piping without changes in direction are laid, the use of the pipe support channel is recommended for the RAU-PE-Xa pipes.

- For installation without the pipe support channel, place the fixed points at intervals of 6 m.
- Ensure sufficient space for the piping to expand and a safe pipe fixation.

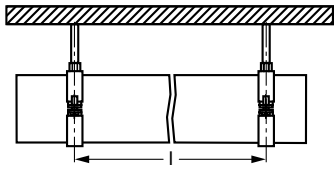
Pipe type	Pipe size [mm]	l = Maximum pipe clamp distance		
		without pipe support channel [m]	with pipe support channel [m]	
				
Universal pipe RAUTITAN stabil stabil	16	1	–	
	20	1,25	–	
	25	1,5	–	
	32	1,75	–	
	Gas pipe RAUTITAN gas stabil gas stabil	40	2	–
		50	1,8	–
Universal pipe RAUTITAN flex flex	63	2	–	
	16	1	2	
	20	1	2	
	25	1,2	2	
	32	1,4	2	
	40	1,5	2	

Tab. 49-1 Approximate values for pipe clamp intervals

In special installation situations (e.g. reinforcement of bending stiffness, increase in pipe clamp spacing), it is possible to use the support channels with RAUTITAN stabil or RAUTITAN gas stabil pipe, although this has no influence on the calculation of the temperature-related change in length and the support channels cannot be used in the bending leg area.

50 Thermal length changes

50.01 Guidelines

Due to physical laws, all piping materials expand when heated and contract when cooled. This effect, which occurs regardless of the piping material, must be taken into account in the installation of drinking water, heating and gas pipes. This also applies to the piping of the RAUTITAN system.

The thermal change in length occurs mainly due to the different installation, ambient and operating temperatures. During installation, appropriate pipe routing with provisions for movement (e.g. at changes in direction) and corresponding space for expansion of the piping must always be taken into account. Additional deflection legs, e.g. U expansion bends or lyre loops, are usually only necessary for larger changes in length.



The pipes RAUTITAN flex used with support channel and the pipes RAUTITAN stabil and RAUTITAN gas stabil have a small thermal length change (see Tab. 50-1).

When using the support channels in conjunction with RAUTITAN stabil or RAUTITAN gas stabil pipes, it is not taken into account in the calculation of the temperature-related change in length and must not be used in the bending leg area.

50.02 Calculation of length changes

The thermal change in length is calculated with the following equation:

$$\Delta L = \alpha \cdot L \cdot \Delta T$$

ΔL = Length change in mm

α = Coefficient of linear expansion in $\frac{\text{mm}}{\text{m}\cdot\text{K}}$

L = Length of the piping in m

ΔT = Temperature difference in K

The coefficient of linear expansion must be chosen according to the employed pipe type and any additionally installed pipe support channel.

Determining the pipe length L

The pipe length L used in the calculation results from the length of the piping installed by the customers. This can be subdivided by installing fixed points or additional deflection legs.

Determining the temperature difference ΔT

In the determination of the temperature difference ΔT , the laying temperature as well as the minimum and maximum temperatures of the pipe wall during operation (e.g. thermal disinfection) and when the system is out of service must be taken into account in the calculation.

Pipe type	Pipe size	Coefficient of linear expansion α [$\frac{\text{mm}}{\text{m}\cdot\text{K}}$]	Material constant C
Formula		$\Delta L = \alpha \cdot L \cdot \Delta T$	$L_{BS} = C \cdot \sqrt{d_a} \cdot \Delta L$
Universal pipe RAUTITAN stabil stabil	16–63	0.026	33
Gas pipe RAUTITAN gas stabil gas stabil	16–40		
Universal pipe RAUTITAN flex flex	16–40 without pipe support channel	0.15	12
	16–40 with pipe support channel	0.04	–

Tab. 50-1 Coefficients of linear expansion (approximate values) and material constants for deflection leg calculation (approximate values)

51 Deflection legs

Thermal changes in length can be accommodated by deflection legs. RAU-PE-Xa pipes are particularly suitable for this due to their flexible material.

A deflection leg is the freely moveable pipe length, which can take up the required length change. The length of the deflection leg is influenced mainly by the material (material constant C).

Deflection legs result mostly from changes in direction of the piping.

For long lengths of piping, additional deflection legs must be installed in the piping to compensate the thermal change in length.



Do not fit pipe support channels or pipe fastenings close to deflection legs to avoid preventing the piping from bending.

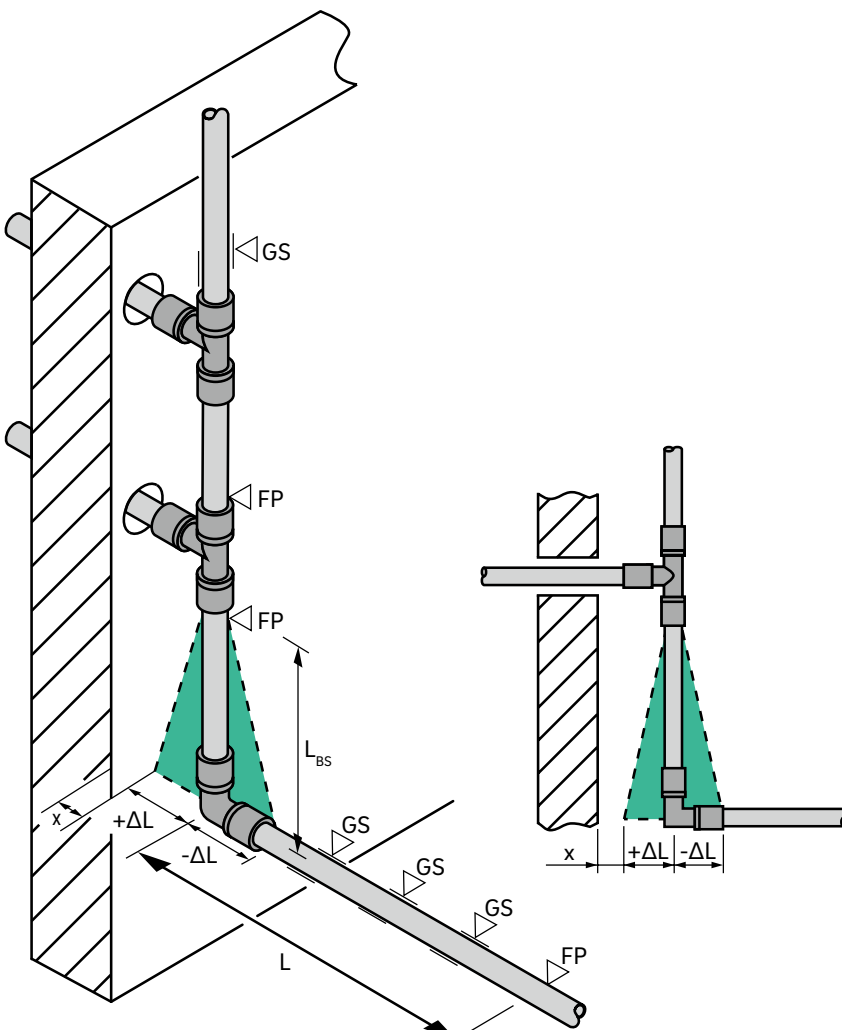

Fig. 51-1 Deflection legs

L_{BS} Length of the deflection leg

ΔL Thermal changes in length

L Pipe length

x Minimum distance of the pipe from the wall

FP Fixed point clamp

GS Slide clamp

51.01 Calculation of deflection leg length

The minimum length of deflection legs (BS) is calculated by the following formula:

$$L_{BS} = C \cdot \sqrt{d_a \cdot \Delta L}$$

- L_{BS} = Length of the deflection leg in mm
- C = Material constant of the piping material
- d_a = Outside pipe diameter in mm
- ΔL = Length change in mm

Approximate values for the material constant C see Tab. 50-1, page 194.



Do not fit pipe support channels or pipe fastenings close to deflection legs to avoid preventing the piping from bending.

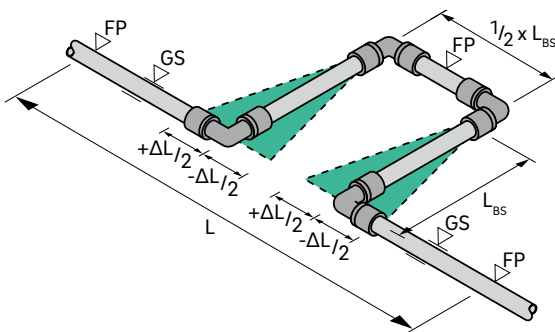

Fig. 51-2 U expansion bends

- L_{BS} Length of the deflection leg
- ΔL Thermal change in length
- L Pipe length
- FP Fixed point clamp
- GS Slide clamp

51.02 Calculation examples

The piping length L , for which the thermal change in length is to be accommodated at a deflection leg, is 7 m.

The temperature difference between the minimum and maximum value (installation temperature and subsequent operating temperature) is 50 K. The employed pipe has an outside diameter of 25 mm. What length of deflection leg is required in dependency on the laid pipe type?

Calculation of the deflection leg length with the universal pipe RAUTITAN stabil and gas pipe RAUTITAN gas stabil

stabil	gas stabil
--------	------------

$$\Delta L = a \cdot L \cdot \Delta T$$

$$\Delta L = 0.026 \frac{\text{mm}}{\text{m} \cdot \text{K}} \cdot 7 \text{ m} \cdot 50 \text{ K}$$

$$\Delta L = 9.1 \text{ mm}$$

$$L_{BS} = C \cdot \sqrt{d_a \cdot \Delta L}$$

$$L_{BS} = 33 \cdot \sqrt{25 \text{ mm} \cdot 9.1 \text{ mm}}$$

$$L_{BS} = 498 \text{ mm}$$

Calculation of the deflection leg length with RAU-PE-Xa pipes mounted with pipe support channel

flex

$$\Delta L = a \cdot L \cdot \Delta T$$

$$\Delta L = 0.04 \frac{\text{mm}}{\text{m} \cdot \text{K}} \cdot 7 \text{ m} \cdot 50 \text{ K}$$

$$\Delta L = 14 \text{ mm}$$

$$L_{BS} = C \cdot \sqrt{d_a \cdot \Delta L}$$

$$L_{BS} = 12 \cdot \sqrt{25 \text{ mm} \cdot 14 \text{ mm}}$$

$$L_{BS} = 224 \text{ mm}$$

Assessment of the results

The universal pipe RAUTITAN stabil has a lower thermal change in length than a RAU-PE-Xa pipe due to its aluminium sheath. However, the required deflection leg length for the RAU-PE-Xa is smaller due to the flexible pipe material.

For metallic pipe materials, a substantially larger deflection leg is required with the same operating parameters during installation, due to the significantly higher material constant (C), than for the pipes of the RAUTITAN system.

51.03 Calculation diagrams to determine deflection legs

Universal pipe RAUTITAN stabil and gas pipe RAUTITAN gas stabil, sizes 16–63

stabil gas stabil

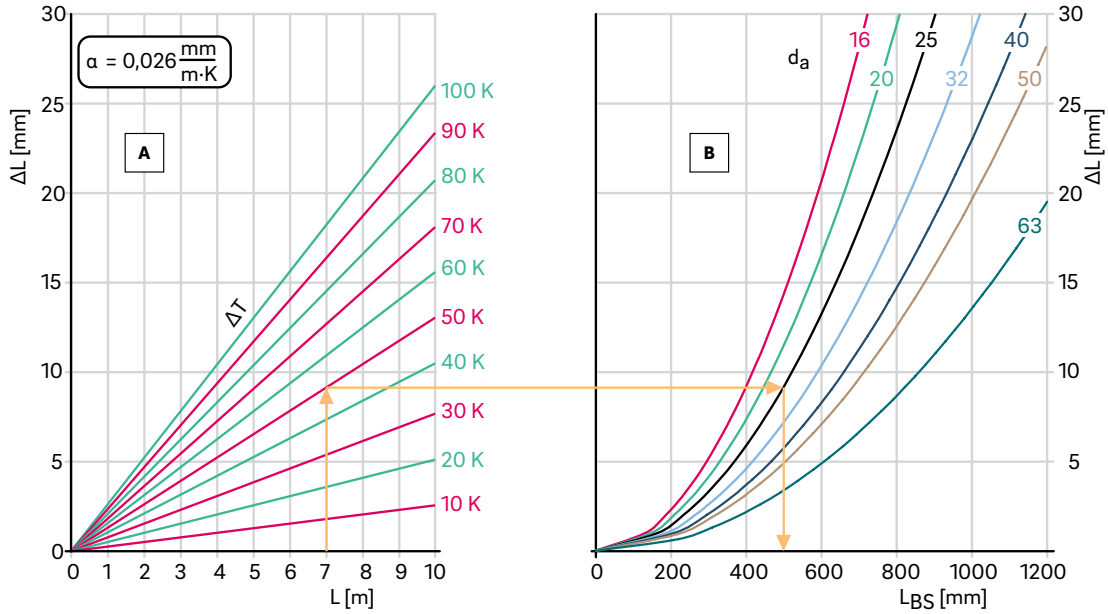

- [A] Thermal change in length
- [B] Deflection leg determination
- ΔL Change in length
- L Pipe length

- L_{BS} Deflection leg length
- ΔT Temperature difference
- d_a Outer pipe diameter

Universal pipe RAUTITAN, sizes 16–40 without pipe support channel

flex

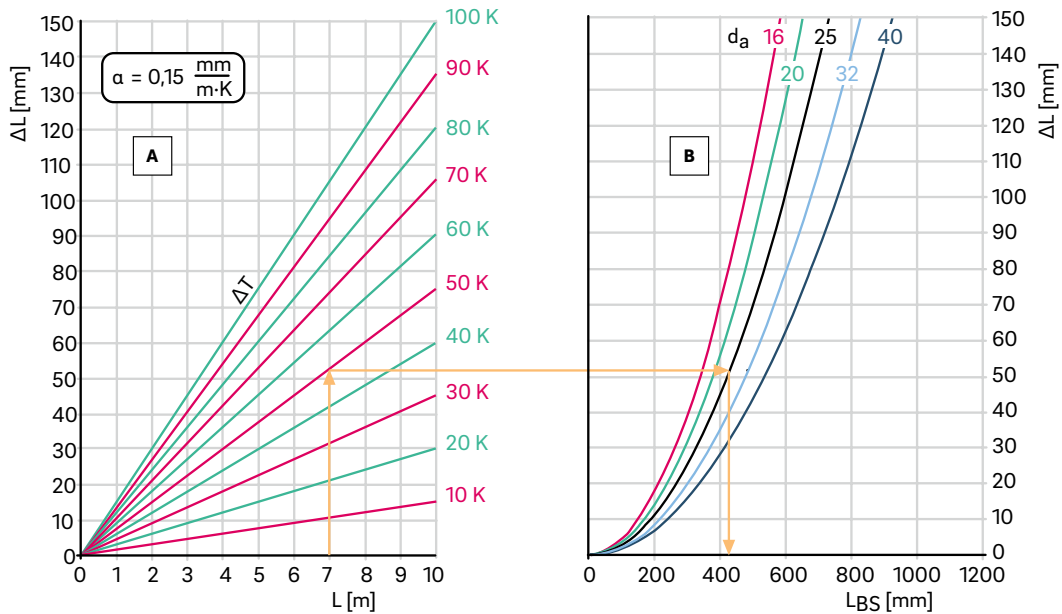

- [A] Thermal change in length
- [B] Deflection leg determination
- ΔL Change in length
- L Pipe length

- L_{BS} Deflection leg length
- ΔT Temperature difference
- d_a Outer pipe diameter

Universal pipe RAUTITAN flex, sizes 16–40 with pipe support channel

flex

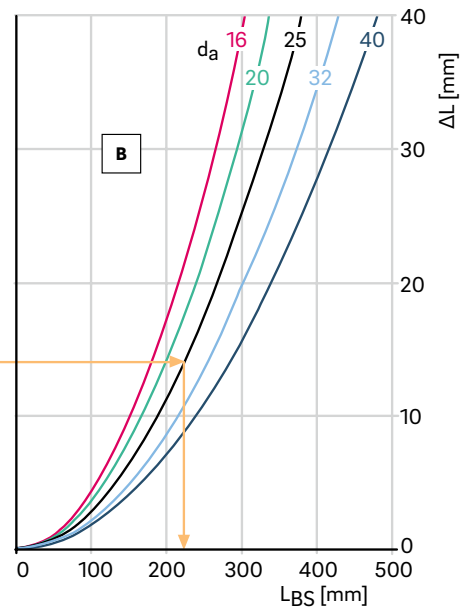
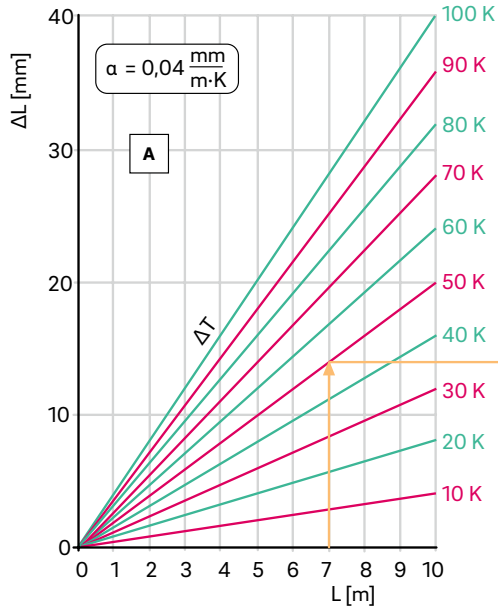

- A Thermal change in length
- B Deflection leg determination
- ΔL Change in length
- L Pipe length

- L_{BS} Deflection leg length
- ΔT Temperature difference
- d_a Outer pipe diameter

52 Fundamental regulations on laying pipes

52.01 Pipe installation in areas subject to frost

Piping has to be frost-free. In areas subject to frost, like e.g. permanent unheated rooms, a frost protection using pipe insulation is generally not enough.

- In these areas the piping has to be equipped with auxiliary heating or has to be purged during the cold period.
- Suitable devices have to be included during the installation design.

52.02 Laying on the raw floor

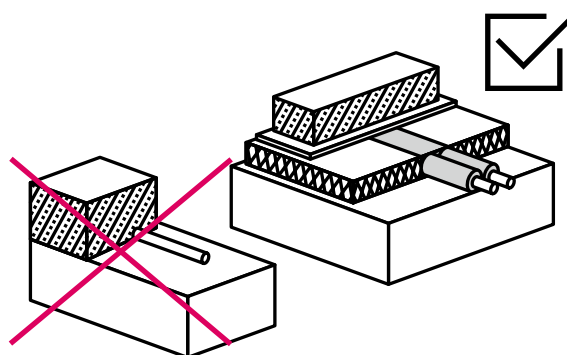

Fig. 52-1 Laying with a compensating layer

- Details on protecting and insulating the piping can be found in the respective chapters.
- Always lay RAUTITAN piping in insulation in the drinking water and heating installation.
- Take note of the necessary height produced by the insulated piping in the planning phase.
- Fasten the pipes on the floor (take note of the specifications in DIN 18 560, Floor screeds in building construction).
- Lay piping in a suitable compensating layer to attain a flat surface to receive the insulating layer and impact sound insulation.

52.03 Inadmissible heating of pipes

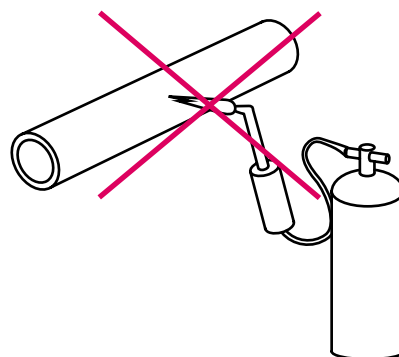

Fig. 52-2 Protect piping against inadmissible overheating

Make sure during the construction phase that piping, etc. is not exposed by other contractors to inadmissible temperatures (e.g. when sealing bitumen sheeting, or welding or soldering in the direct vicinity of unprotected piping).

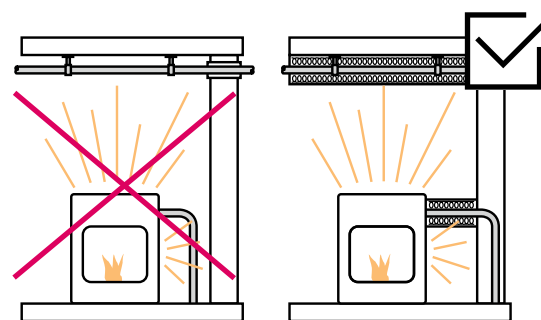

Fig. 52-3 Schutz vor thermischer Belastung

- Piping close to devices with high thermal emissions must be insulated sufficiently and permanently protected against inadmissible heating.
- The maximum allowed operating pressure (e.g. operating temperature and duration) apply.

52.04 Laying on bitumen sheeting and bitumen coatings

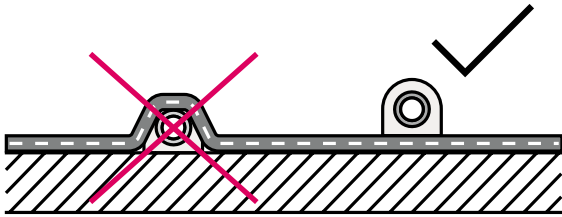

Fig. 52-4 Laying is permissible only on one bitumen sheeting

Do not lay pipes under bitumen sheeting. Laying under a bitumen sheeting can lead to damage to the piping or to the bitumen sheeting.

- Before laying on solvent-bearing bitumen sheeting or bitumen coatings, they must have dried thoroughly.
- Observe the setting time specified by the manufacturer.
- Before beginning laying, ensure that impairment of the piping and the drinking water is prevented.
- When laying pipes in the vicinity of bitumen sheeting to be heated with a torch, protect the piping sufficiently against heating.



Details on insulating and laying RAUTITAN piping in the drinking water, heating and gas installation can be found in the section „Insulation and noise protection“, page 123 ff.

52.05 Laying under hot asphalt screed

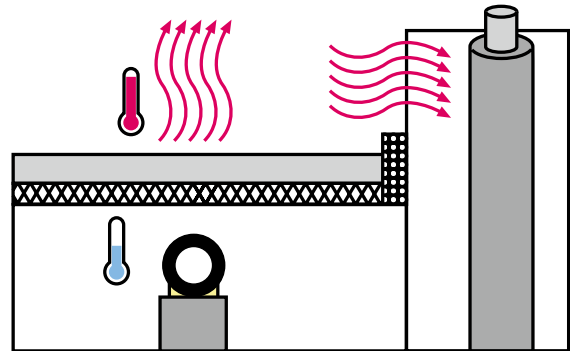

Fig. 52-5 Laying under hot asphalt screed

Hot asphalt screeds are laid at a temperature of approx. 250 °C in the building. To protect the piping from overheating, the proper steps need to be taken. Since these are dependent on the structural conditions and cannot be influenced by REHAU, these must be coordinated with and approved by the planner.

- Do not insert RAUTITAN gas pipes under hot asphalt screed.
- Take the appropriate measures to ensure that the drinking water and heating piping (e.g. pipes, fittings, compression sleeves, joints) and the pipe insulation do not at any point exceed 100 °C.



Agree with the contractor laying the hot asphalt screed on suitable insulating and protective measures for the installation and laying of the hot asphalt screed in order to prevent overheating of the piping.

52.06 External installation

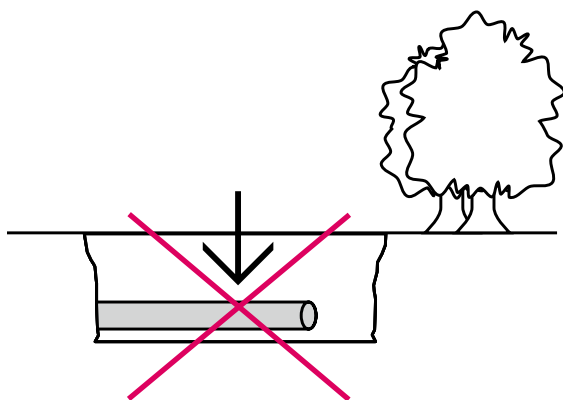

Fig. 52-6 Underground laying is inadmissible

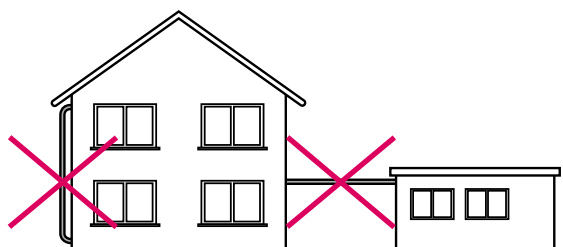

Fig. 52-7 Outside laying is inadmissible (RAUTITAN gas stabil) or only admissible for water piping if the corresponding protective measures have been taken



Gas pipes RAUTITAN gas stabil:

- Shall not be used outside building
- Please refer to the chapter „External installation in-ground (allowed exception)“, page 117 for the description of specific installation cases outside building with RAUTITAN gas stabil.

Piping:

- Do not use for laying in ground
- Protect against UV radiation
- Protect against frost
- Protect against high temperatures
- Protect against damage



When laying in ground, use the REHAU systems for groundworks. Additional information on this can be found online at www.rehau.com or www.rehau.com/tiefbau

52.07 Laying exposed to UV radiation

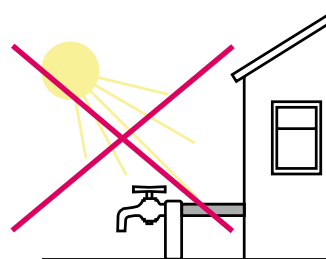

Fig. 52-8 Unprotected laying in areas exposed to UV radiation is not permitted
Example: Outdoors

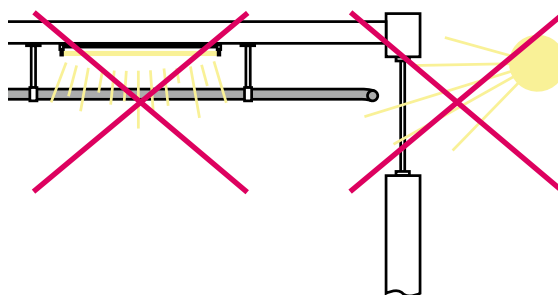

Fig. 52-9 Unprotected laying in areas exposed to UV radiation is not permitted
Example: Indoors



- Store and transport pipes protected against UV radiation.
- Protect piping from UV rays in areas where UV radiation can occur (e.g. sunlight, neon light).
- Please refer to the chapter „31.05 Indoor installation“, page 116 for additional information about the protection of the RAUTITAN gas pipes in areas exposed to UV radiations.

52.08 Light transmission

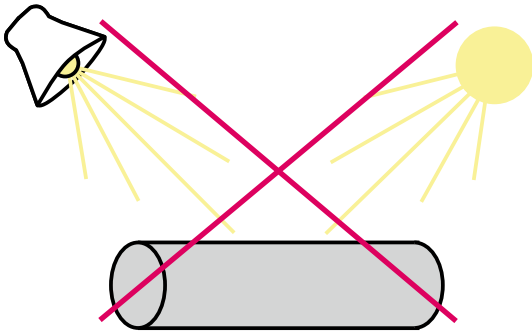

Fig. 52-10 Protect against exposure to light



The universal pipe RAUTITAN flex is permeable to light. Light exposure can be detrimental to the hygiene of the drinking water.

Protect pipes against exposure to light (e.g. close to windows and lamps).

52.09 Auxiliary heating

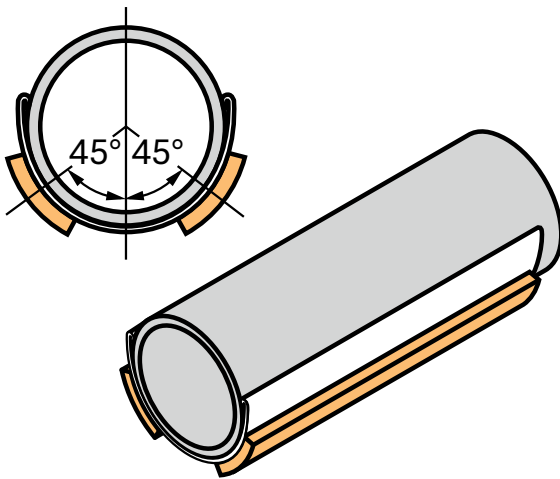

Fig. 52-11 Example of laying with auxiliary heating

- If pipes are laid with the pipe support channel, the heating strip must be attached to the outside of the pipe support channel.
- Take the appropriate measures to ensure that the piping and connection components do not at any point exceed 70 °C.
- When installing heating strips on pipes, observe the laying instructions of the auxiliary heating manufacturer.

52.10 Potential compensation

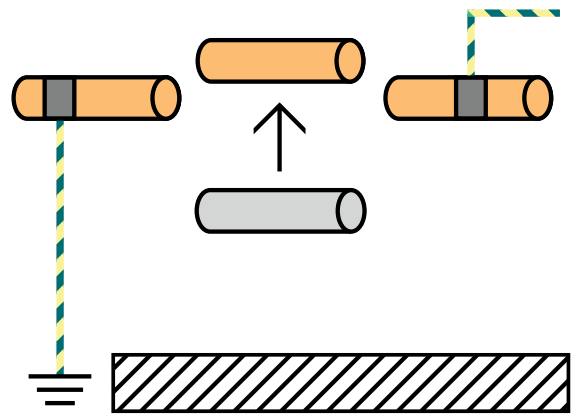

Fig. 52-12 Potential compensation when exchanging pipes



RAUTITAN piping must not be used as an earth conductor for electrical systems as per DIN VDE 0100.

After replacement of existing metal pipe installations with the RAUTITAN system, the function of potential compensation and the effectiveness of the electrical safety devices must be verified by an electrician.

53 Advices about system components until 2019

Some system components, which has produced and sold before 2019, are yet restrictively applicable or not applicable at all anymore. Please following advices about the compatibility of the system components to each other have to be considered.



Only push polymer RAUTITAN PX compression sleeves onto polymer RAUTITAN PX fittings.

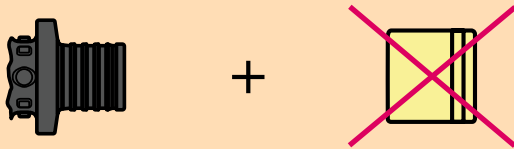

Fig. 53-1 Unapproved combination RAUTITAN PX with brass compression sleeves

53.01 Advices about fitting contours when using the universal pipe RAUTITAN stabil, size: 16–32

stabil

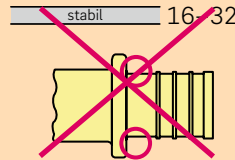

Fig. 53-2 Brass fitting without shaped end collars, size 16–32

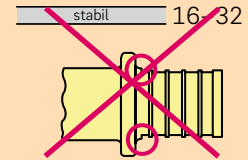

Fig. 53-3 Brass fitting with partially shaped end collars, size 16–32

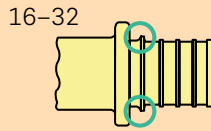

Fig. 53-4 Fitting with fully shaped end collar, size 16–32



With universal pipes RAUTITAN stabil and brass fittings, always use brass parts with fully shaped end collars.

Since 1997, production at REHAU has been changed completely to incorporate fitting contours with end collars in sizes 16–32.

53.02 Fittings RAUTITAN MX: Fittings for plumbing applications up to 2013

Use

The brass fittings which were sold up to 2013 (RAUTITAN MX and RAUTITAN gas) shall not be used anymore since 10th April 2017.

53.03 Transition to other pipe materials

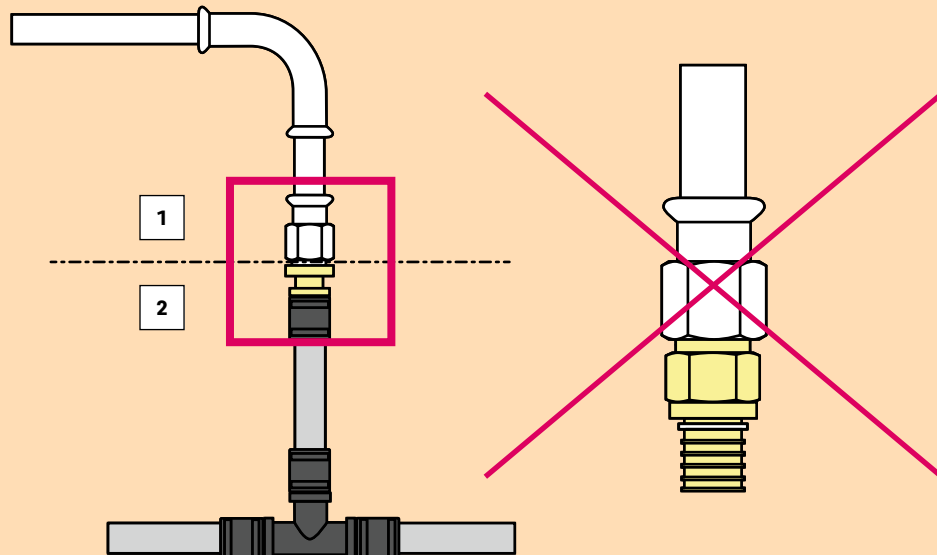

Fig. 53-5 No direct transition from stainless steel systems to RAUTITAN MX

- 1 Stainless steel system
- 2 RAUTITAN system with RAUTITAN MX (brass) adapters

A direct screwed connection of threaded fittings RAUTITAN MX made of special dezincification-resistant brass to threaded RAUTITAN SX made of stainless steel is since 2004 not allowed.

We recommend the use of a transition piece made of gunmetal between both fittings.

53.04 Fire collars RAU-VPE

Since the end of 2017 the fire collars RAU-VPE for RAUTITAN flex are no longer marketed.

Since October 2018 with the expiration of abZ Z-19.17-1210, the use of RAU-VPE fire collars is no longer allowed.

Available solutions for fire protection of RAUTITAN flex pipes can be found in the section „36 Fire protection“, page 137.

54 Advices about system components until 2013

Some system components, which has produced and sold before 2013, are yet restrictively applicable or not applicable at all anymore.
Please following advices about the compatibility of the system components to each other have to be considered.



Only push polymer RAUTITAN PX compression sleeves onto polymer RAUTITAN PX fittings.

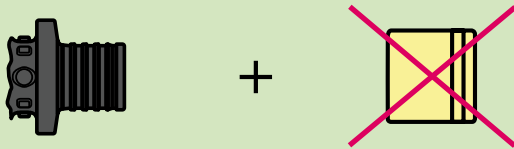

Fig. 54-1 Unapproved combination RAUTITAN PX with brass compression sleeves

54.01 RAUTHERM SL



The yellow PE-X pipe RAUTHERM SL, which was available up until 1999, may not be used in the gas installation!

RAUTHERM SL was available in sizes 17 x 2.0 mm and 20 x 2.0 mm and approved for heating installation in the skirting.

If you should still have leftover parts of the RAUTHERM SL pipe, you may no longer use them. Store the RAUTHERM SL pipe in such a way that it cannot be mixed up with the gas pipe RAUTITAN gas stabil.

Contact your local REHAU sales office. The sales offices will take back your old heating pipes RAUTHERM SL.

54.03 Fittings MX: Fittings for drinking water and heating application up to 2013

Use

The brass fittings which were sold up to 2013 (RAUTITAN MX and RAUTITAN gas) shall not be used anymore. We recommend the use of RAUTITAN LX or RAUTITAN PX in drinking water installations. Fittings made of dezincification-resistant special brass should preferable only be used for heating applications.

54.02 Advices about fitting contours when using the universal pipe RAUTITAN stabil, size: 16–32

stabil

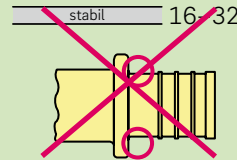

Fig. 54-2 Brass fitting without shaped end collars, size 16–32

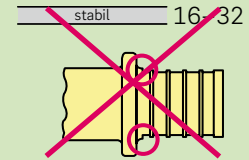

Fig. 54-3 Brass fitting with partially shaped end collars, size 16–32

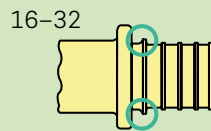



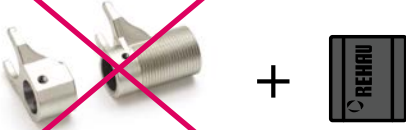

Fig. 54-4 Fitting with fully shaped end collar, size 16–32



With universal pipes RAUTITAN stabil and brass fittings, always use brass parts with fully shaped end collars.

Since 1997, production at REHAU has been changed completely to incorporate fitting contours with end collars in sizes 16–32.

54.04 Notes on the compression jaws in size 40 by 2009

Compression jaws, old Ø 40	Compression sleeves RAUTITAN PX Ø 40
Compression jaws set 40 (Gold-yellow) 137805-001 138223-001	
Compression jaws set M1 40 (Gold-yellow) 137374-001 138333-001	
Compression jaws set G1/G2 40 (Gold-yellow) 137964-001	

Tab. 54-1 Compression jaws for RAUTITAN PX compression sleeves, size 40

54.05 Notes on the expanding tool QC and the expanding tool RO

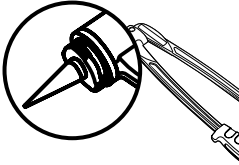
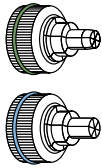
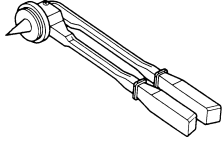
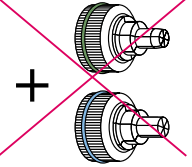
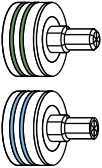
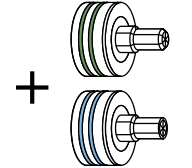
		Expanding tools and expander heads			
Expanding tool QC		Expander heads		Expanding tool RO	Expander heads
Material number 12141761001 Article number 214176-001		QC 	Material number 11395921001 Article number 139592-001		QC 
		RO 			RO 

Tab. 54-2 Expanding tools and expander heads

The black expanding tool QC can be used without restriction with expander heads RO with thread connection and QC with bayonet lock.



The new expander heads QC, with a single marking ring shall not be used with the expanding tool RO (silver).

55 Components summary

55.01 Components for universal pipe RAUTITAN stabil

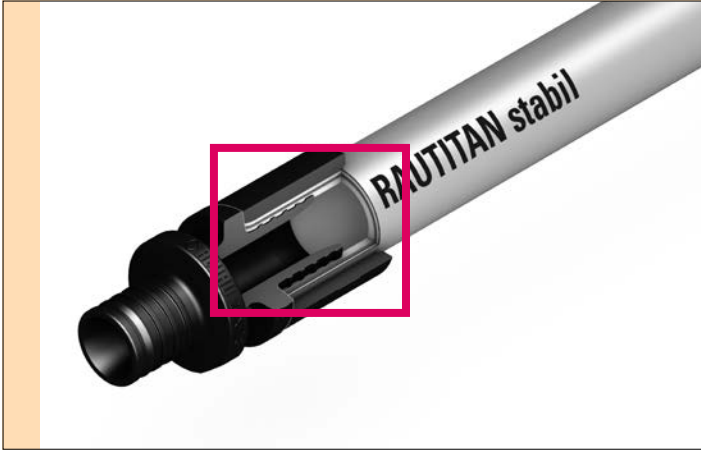

Fig. 55-1 Universal pipe RAUTITAN stabil with aluminium layer

Area of application

- Drinking water installation
- Heating installation
- Radiator connection system skirting
- Underfloor heating/cooling

Size	Fittings	Compression sleeves	Cutting off	Expanding	Expander head	Detaching joint
16						
20						
25						
32						
40						
50						
63						

SL-Fitting-Sets

56 Components summary

56.01 Components for universal pipe RAUTITAN stabil

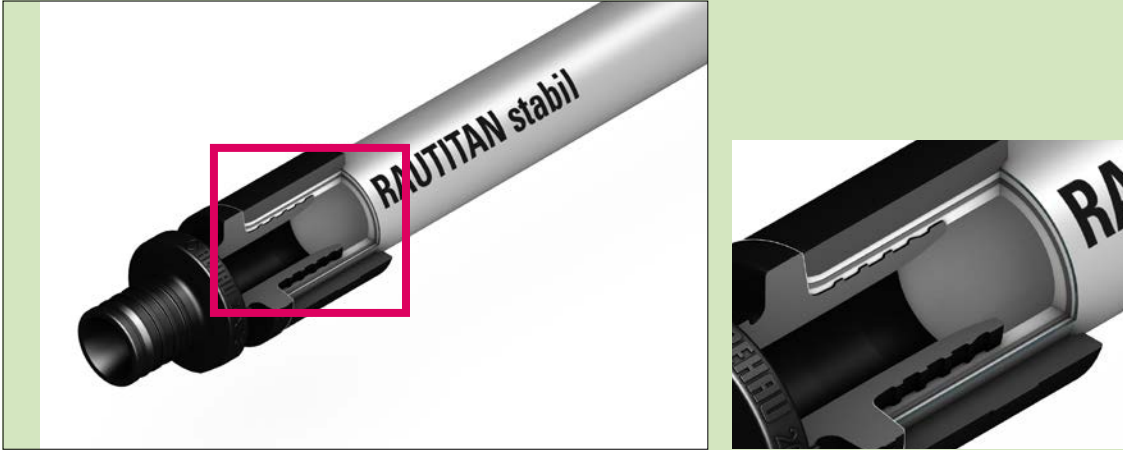

Fig. 56-1 Universal pipe RAUTITAN stabil with aluminium layer

Area of application

- Drinking water installation
- Heating installation
- Radiator connection system skirting
- Underfloor heating/cooling

Size	Fittings	Compression sleeves	Cutting off	Expanding	Expander head	Detaching joint
16						
20						
25						
32						
40	 SL-Fitting-Sets					
50						
63						

56.02 Components for pipes made from RAU-PE-Xa



Area of application

- Drinking water installation
- Heating installation
- Underfloor heating/cooling

Fig. 56-2 Pipes made from RAU-PE-Xa

Size	Fittings	Compression sleeves	Cutting off	Expanding	Expander head	Detaching joint
16						
20						
25						
32						
40						

56.03 Components for pipes made from RAU-PE-Xa



Area of application

- Drinking water installation
- Heating installation
- Underfloor heating/cooling

Fig. 56-3 Pipes made from RAU-PE-Xa

Size	Fittings	Compression sleeves	Cutting off	Expanding	Expander head	Detaching joint				
16										
20										
25										
32										
40										











56.04 Components for gas pipe RAUTITAN gas stabil

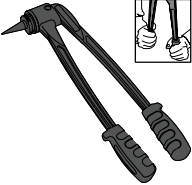

Fig. 56-4 Gas pipe RAUTITAN gas stabil

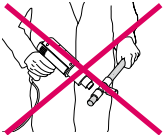
Area of application

- Gas installation inside buildings according to NEN 1078 for conveying natural gas (hot fuel gases acc. EN 437)

Size	Fittings	Compression sleeves	Cutting off	Expanding	Expander head	Detaching joint
16	  Description yellow dot					 gas stabil
20						
25						
32						
40						

57 Standards, regulations and guidelines

§

Observe the applicable national and international laying, installation, accident prevention and safety regulations when installing piping systems, as well as the instructions in this Technical Information.

Also observe the applicable laws, standards, guidelines and regulations (e.g. DIN, EN, ISO, DVGW, VDE and VDI) as well as regulations on environmental protection, provisions of professional associations and regulations of the local public utility companies.

Areas of application not contained in this Technical Information (special applications) require consultation with our Applications Department.

For detailed advice, consult your REHAU sales office.

The planning and installation instructions are directly connected with the respective REHAU product.

References are made to excerpts from generally applicable standards and regulations.

Observe the respectively valid issues of the guidelines, standards and regulations.

Further standards, regulations and guidelines with regard to the planning, installation and operation of drinking water, heating and building technology systems must also be taken into account, but are not a part of this Technical Information.

Reference is made to the following standards, regulations and directives in the Technical Information (the current status always applies):

DIN 1988
Codes of practice for drinking water installations (TRWI)

DIN 2000
Central drinking water supply - Guidelines regarding requirements for drinking water, planning, construction, operation and maintenance of plants

DIN 3546
Stop-valves for domestic water supply

DIN 4102
Fire behaviour of building materials and components

DIN 4102-1
Fire behaviour of building materials and building components - Part 1: Building materials; concepts, requirements and tests

DIN 4108
Thermal protection and energy economy in buildings

DIN 4109
Sound insulation in buildings

DIN 4726
Warm water surface heating systems and radiator connecting systems - Plastic piping systems

DIN 16892
Crosslinked polyethylene (PE-X) pipes - General requirements, testing

DIN 16893
Crosslinked polyethylene (PE-X) pipes - Dimensions

DIN 18560
Floor screeds in building construction

DIN 50916-2
Testing of copper alloys; stress corrosion and cracking test using ammonia; testing of components

DIN EN 442
Radiators and convectors

DIN EN 806
Codes of practice for drinking water installations

DIN EN 1057
Copper and copper alloys - Seamless, round copper tubes for water and gas in sanitary and heating applications

DIN EN 1717
Protection against pollution of potable water installations and general requirements of devices to prevent pollution by backflow

DIN EN 1982
Copper and copper alloys - Ingots and castings

DIN EN 10088
Stainless steels

DIN EN 10226
Pipe threads where pressure-tight joints are made on the threads

DIN EN 12164
Copper and copper alloys - Rod for free machining purposes

DIN EN 12165
Copper and copper alloys – Wrought and unwrought forging stock

DIN EN 12168
Copper and copper alloys - Hollow rod for free machining purposes

DIN EN 12502-1
Protection of metallic materials against corrosion – Guidance on the assessment of corrosion likelihood in water distribution and storage systems

DIN EN 12828
Heating systems in buildings – Design of water-based heating systems

DIN EN 13163 to DIN EN 13171
Thermal insulation products for buildings

DIN EN 13501
Fire classification of construction products and building elements

DIN EN 13501-1
Fire classification of construction products and building elements - Part 1: Classification using data from reaction to fire tests

DIN EN 14291
Foam producing solutions for leak detection on gas installations

DIN EN 14313
Thermal insulation materials for building services and industrial installations - Factory-made polyethylene foam (PEF)

DIN EN 14336
Heating systems in buildings

DIN EN 16313
Connections for heating and cooling appliances - Detachable connection with outside threaded pipe G ¾ A and inside cone

DIN EN ISO 6509
Corrosion of metals and alloys – Determination of dezincification resistance of brass

DIN EN ISO 15875
Plastic piping systems for hot and cold water installations - Crosslinked polyethylene (PE-X)

DIN EN ISO 21003
Multilayer piping systems for hot and cold water installations inside buildings

DIN VDE 0100
(Summary)
Electrical systems in building
Setting up high-voltage current systems
Setting up low-voltage current systems
Guidelines for electrical systems

DIN VDE 0100-701
Low-voltage electrical installations - Requirements for special installations or locations - Part 701: Locations containing a bath or shower

DVGW W 270
Reproduction of micro-organisms on materials for the drinking water area

DVGW W 534
Pipe connectors and connections in the drinking water installation

DVGW W 551
Drinking water heating and drinking water piping systems - Technical measures to reduce Legionella growth - Design, construction, operation and rehabilitation of drinking water installations

DVGW W 551-3
Hygiene in Potable Water Installations - Part 3: Cleaning and Disinfection

GEG
German Building Energy Law

Council directive 98/83/EC of 3 November 1998 on the quality of water intended for human consumption

Council directive relating to machinery (89/392/EEC) including amendments

ISO 7
Pipe threads where pressure-tight joints are not made on the threads

ISO 228
Pipe threads where pressure-tight joints are not made on the threads

ISO 10508
Plastic piping systems for hot and cold water installations - Guidance for classification and design

LBO

Regional building laws of the states of the Federal Republic of Germany

MBO

German Building Code for the states of the Federal Republic of Germany

MLAR

Sample Line Systems Guidelines

Muster-Feu-VO

Sample firing equipment regulation

NEN 1078

Gas supply at an operating pressure of 500 mbar

TrinkwV

Drinking Water Ordinance

VDI 2035

Prevention of damage in water heating installations

VDI 6023

Hygiene in drinking water installations - Requirements for planning, execution, operation and maintenance

VOB

German Construction Contract Procedures

ZVSHK data sheets

German Central Association for Plumbing, Heating, Air-conditioning/Building and Energy Technology (ZVSHK/GED)

REHAU sales offices

www.rehau.com

Below, you will find the individual sales offices with their addresses and phone numbers:

D: Frankfurt:
Gewerbegebiet Dietzenbach Nord
Waldstraße 80-82,
63128 Dietzenbach
Tel.: 06074 4090-0

Nürnberg:
Ytterbium 4
91058 Erlangen/Eltersdorf
Tel.: 09131 93408-0

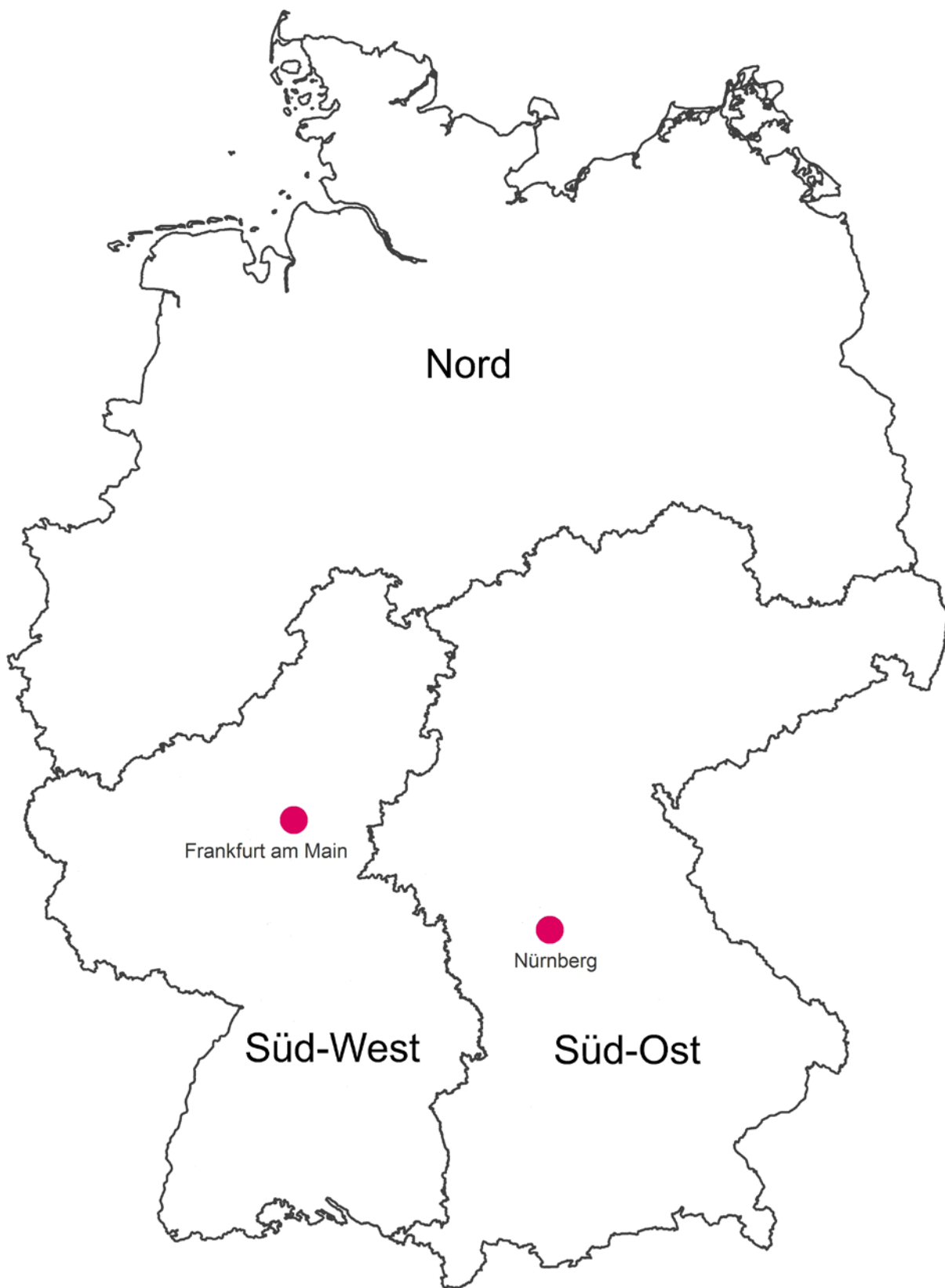

This document is protected by copyright. All rights based on this are reserved. No part of this publication may be translated, reproduced or transmitted in any form or by any similar means, electronic or mechanical, photocopying, recording or otherwise, or stored in a data retrieval system.

Our verbal and written advice with regard to usage is based on years of experience and standardised assumptions and is provided to the best of our knowledge. The intended use of REHAU products is described comprehensively in the technical product information. The latest version can be viewed at www.rehau.com/TI. We have no control over the application, use or

processing of the products. Responsibility for these activities therefore remains entirely with the respective user/processor. Where claims for liability nonetheless arise, they shall be governed exclusively according to our terms and conditions, available at www.rehau.com/conditions, insofar as nothing else has been agreed upon with REHAU in writing. This shall also apply for all warranty claims, with the warranty applying to the consistent quality of our products in accordance with our specifications. Subject to technical changes.

www.rehau.de/verkaufsbueros

© REHAU Industries SE & Co. KG
Rheniumhaus, Helmut-Wagner-Str. 1
D 95111 Rehau
Germany

893621 MM.YYYY