



---

## HEAT SHRINK SHROUD

All-purpose joint insulation

---



# INFORMATION AND SAFETY WARNINGS

## Notes about these installation instructions

### Validity

These installation instructions are valid worldwide.

### Pictograms and logos



Safety warnings



Legal information



Important information that must be noted



### Currentness of the installation instructions

To ensure your own safety and the correct use of our products, please check at regular intervals whether a newer version of these installation instructions is available. The issue date of your installation instructions is always printed in the bottom left-hand corner of the cover page. You can obtain the current installation instructions from your REHAU sales office, specialist wholesaler or you can download it from the internet at [www.rehau.com/en-us](http://www.rehau.com/en-us) or <https://www.rehau.com/us-en/downloads/2006944>.

### Safety warnings and operating instructions

- For your own safety and the safety of other people, please read all safety warnings and operating instructions carefully and in full before commencing installation.
- Keep the installation instructions handy for easy access
- If you have not understood the safety instructions or the individual assembly guidelines or find them unclear, please contact your REHAU sales office

**Non-compliance with the safety information may lead to damage to property or personal injury.**



### Use in line with specifications

The REHAU pipe systems and their components must only be planned, installed and operated as described in the current applicable technical information or in the relevant installation instructions. Any other use is improper and therefore prohibited.

For more detailed advice, please contact your REHAU sales office. Proper use entails compliance with all of the instructions in the technical information as well as the installation, operating and maintenance instructions. We accept no liability for improper use or prohibited modifications to the product and all resultant consequences.



Observe all applicable national and international regulations relating to laying, installation, safety and the prevention of accidents when installing pipe systems, as well as the instructions in the technical information and these installation instructions. Please also observe the applicable laws, standards, instructions and regulations (e.g. DIN, EN, ISO, DVGW, TRGI, VDE and VDI) as well as regulations on environmental protection, regulations of the Employer's Liability Insurance Association and specifications of the local public utilities companies. Please ensure that the guidelines, standards and regulations in use are the valid version in each case. The design and assembly instructions relate directly to the REHAU product in each case. Some sections refer to generally applicable standards or regulations.

More specific standards, regulations and instructions relating to the planning, installation and operation of drinking water or heating systems or systems for building services must also be observed and do not form part of this technical information.

Areas of application that are not included in this technical information (custom applications) require consultation with our Technical Applications department.



### Prerequisites for personnel

- Our systems should only be assembled by people who are authorized to do so and have received training in this.
- Work on electrical installations or pipework components must only be carried out by trained and authorized personnel.

### General precautions

- Keep your workplace clean and free of obstructions
- Ensure that your workplace is adequately lit
- Keep children, pets and unauthorised persons away from tools and the installation areas This applies particularly in the case of renovation work in an occupied area
- Only use the components intended for the respective REHAU system. The application of components from other systems or the use of tools which do not come from the relevant REHAU installation system can result in accidents or other hazards

### Working clothes

- Wear protective goggles, suitable working clothes, safety shoes, a hard hat and a hairnet if you have long hair
- Do not wear loose-fitting clothing or jewellery as they may get caught in moving parts

### During installation

- Always read and follow the operating instructions for the REHAU installation tool you are using
- Improper handling of tools can result in severe cuts, trapped or severed limbs
- Improper handling of tools can damage the jointing components and result in leaks
- REHAU pipe cutters have a sharp blade. Store and handle them in such a way that there is no risk of injury from the REHAU pipe cutters
- When cutting the pipes to size, maintain a safe distance between the hand holding the pipe and the cutting tool
- Never put your hand in the tool's cutting zone or on moving parts during the cutting process
- Following the expansion process, the expanded pipe end returns to its original shape (memory effect). Do not insert any foreign objects into the expanded pipe end during this stage
- Never put your hand in the tool's compression zone or on moving parts during the compression process
- The fitting may fall out of the pipe until the compression process is complete. Risk of injury!
- During maintenance or retooling work and when changing the installation area, always unplug the tool and prevent it from being switched on accidentally



### Operating parameters

- If the operating parameters are exceeded, the pipes and connections are overloaded.  
Therefore, the operating parameters must not be exceeded.

- Adherence to the operating parameters is to be ensured by safety and control facilities (e.g. pressure reducer, safety valves and similar).

### System-specific safety warnings

- Deburr or remove edges on insulating sleeves in order to prevent possible injury
- When sawing or sanding foamed PUR, a dust mask must be worn
- When welding electrofusion couplers and foam moulding with PUR foam for the shroud, the component heats up
- There is a danger of crushing when working with lashing straps to fix the pipes in place. Do not reach into the hazardous areas
- Only make the connection using suitable installation tools
- The relevant operating instructions, instruction leaflet and technical information must be observed when handling tools and making the connection
- Do not use dirty or damaged connection components or tools
- Cordless or mains-operated tools such as A-light2, A3, E3, G2 are unsuitable for permanent operation. A break of min. 15 minutes must be taken after approx. 50 consecutive compressions to allow the appliance to cool down
- You can find the exact allocation of the connection components in the current price list.

# DESCRIPTION OF HEAT-SHRINK SHROUD SYSTEM

## Heat-shrink shroud system for T-, L- and I-shrouds

Connecting points in the ground, for example couplers or T-pieces, are to be insulated and sealed to an insulation quality equivalent to that of the pipes.

REHAU shroud systems with heat-shrink shrouds are available for all-purpose insulation of RAUVITHERM and RAUTHERMEX pipe connections.

The REHAU T, L and I heat-shrink shroud systems are watertight-tested up to 5 mWS, even with a max. angle deviation in the pipe installation of up to 20° (testing carried out in accordance with the increased requirements of EN 489 and by MFPA Leipzig GmbH).



The shrouds are made from extremely robust and impact-resistant PE-HD. The heat-shrink shrouds (see fig.1) are available as T, L and I shapes in two respective sizes.

The full system comprises of:

- PE heat-shrink shroud
- Stainless steel sealing screws (only for T- and L-shrouds)
- Heat-shrink sleeves
- Butyl sealing tape (only for T- and L-shrouds)
- A sealing plug
- A two-component PU foam set

The I-shroud is pushed directly onto the pipe and cannot be screwed on. Therefore, the I-shroud set does not contain any screws.

The heat-shrink sleeve seals the shroud to the pre-insulated pipe. It is internally coated with a hot-melt adhesive to allow a secure and permanent seal.

A high-quality, two-component PU foam is used for the insulation.



The heat-shrink shroud system is only compatible with RAUVITHERM and RAUTHERMEX pipes and custom components for the supply of heat.

- The heat-shrink sleeves and the shrouds must always be pushed onto the pipe prior to completing the joint. They cannot be installed later.
- Observe the installation instructions for the connection system used.



Fig. 1: Shrouds (T-, L-, I-shape)



Fig. 2: Butyl sealing tape and sealing screws



Fig. 3: Heat-shrink sleeves



Fig. 4: Two-component PU foam

Shroud Type	Material No.	Outer Jacket Dimension	Delivery Contents	Material No. for Foam	Foam Size
T-shroud small	13300241001	90-160	T-shroud, 9 screws, 3 heat-shrink sleeves, butylsealingtape,sealingplug	12012731001	7
T-shroud large	13300251001	90-225	T-shroud, 11 screws, 2 heat-shrink sleeves, butylsealingtape,sealingplug	13510631001	9.1
I-shroud small	13300681001	90-160	I-shroud, 2 heat-shrink sleeves, butylsealingtape,sealingplug	12983571001	5
I-shroud large	13300691001	90-225	I-shroud, 2 heat-shrink sleeves, butylsealingtape,sealingplug	13524131001	8
L-shroud small	13300261001	90-160	L-shroud, 2 heat-shrink sleeves, butylsealingtape,sealingplug	12095961001	6
L-shroud large	13300271001	90-225	L-shroud, 2 heat-shrink sleeves, butylsealingtape,sealingplug	13047661001	8.1

An additional foam set, in the size stated, is to be ordered for the installation

Tab. 1: Delivery overview for the heat-shrink shroud system and shroud foam to be added for the insulation of the shroud.



Fig. 5: T-shroud set large or small



Fig. 6: L-shroud set large or small



Fig. 7: I-shroud set large or small

# MAKING A COMPRESSION SLEEVE JOINT

## Cutting the pipe



### Pipes springing back

Pipes that are under pressure may spring out during the cutting process. Cut the pipe carefully without applying pressure if possible, wear suitable protective clothing and keep out of the danger zone.

The end of the pipe must be free from contamination (e.g. adhesive tape, lubricating or adhesive agent) in order to make the connection.



## Stripping the insulation

Measure the length of the insulation to be removed (Tab 2), whereby an additional 40 mm are needed for a clean trim.

The stripping length is chosen in such a way that a safe seal is created using the shroud. To install the jointing system with a compression sleeve, the free pipe length must be at least 3x the length of the compression sleeve, as the sleeve that is pushed onto the pipe must not be affected by the expansion process.

Shroud	Maximum stripping length L for heat-shrink shroud [mm]
Small shroud	210 + 40 for trimming
Large shroud	315 + 40 for trimming

Tab. 2: Stripping lengths for making joints with compression sleeves

### Stripping the insulation for the RAUVITHERM system

Cut the outer jacket of the RAUVITHERM system pipe with a saw or a knife in a longitudinal direction.

Insert the knife a maximum of 5 mm during this process.



### Do not damage the carrier pipe when stripping the insulation!

Carrier pipe sections that are damaged or broken by cuts or scratches must be cut off and thrown away.



Remove the insulation sheets and the foam bone in DUO pipes.

### Stripping the insulation for the RAUTHERMEX system

Cut the outer jacket of the RAUTHERMEX pipe with a saw or a knife in a longitudinal direction and peel off the outer jacket. Insert the knife a maximum of 5 mm during this process.



#### **Do not damage the carrier pipe when stripping the insulation!**

Carrier pipe sections that are damaged or broken by cuts or scratches must be cut off and thrown away.



Remove the PU foam from the section where you have peeled off the outer jacket.



Remove any residual PU foam using abrasive paper.



### Trimming

Trim the pipe ends using a pipe cutter to achieve a square, burr-free cut. To ensure a square cut, the pipe cutter has to tightly rest against the pipe.



#### **Risk of injury**

Observe a safe distance between the hand holding the pipe and the pipe cutter.



A ribbed pipe cutter can also be used from carrier pipe dimensions measuring 50 – 160 mm. Follow the separate installation instructions for the compression sleeve.



## Preparatory measures

### Pushing the heat-shrink sleeves onto the shroud

One heat-shrink sleeve must be pulled over each pipe section that is to be connected, prior to performing the final compression of the entire fitting. Before compression, also push the I- and T-shrouds over the side of the pipe (the T-shroud over the branch). Only the L-shroud can be pushed over the fitting afterwards.



### Pushing on compression sleeves

Push the compression sleeves up to the end of the section that has been stripped of insulation.



The chamfer on the inside (arrow) points towards the connection.

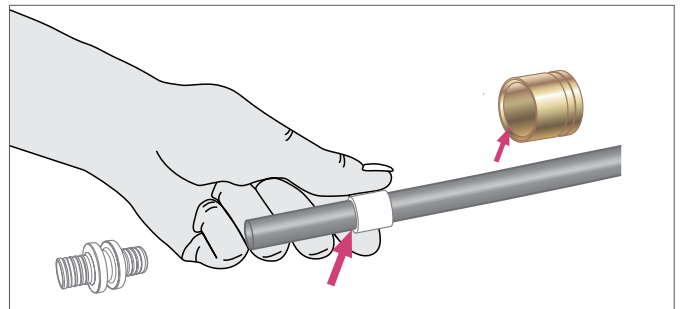

Push the compression sleeve onto the pipe until at least double the compression sleeve length is exposed between the pipe end and compression sleeve.

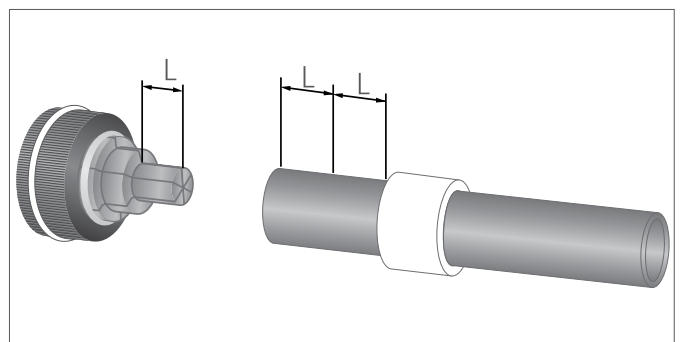



## Expansion

- Push the segments of the expander head onto the pipe up to the stop
- **Avoid tilting the expander head when doing this**
- Expand the pipe once
- Following this, rotate the expander head with a 30° offset. The pipe remains in its initial position during this.
- Expand the pipe end again

Expand the second pipe in the same way for DUO pipes prior to inserting the fitting.



- Observe the safety warnings for the tools
- Check that the expander heads run smoothly and check for contaminations, cleaning them if necessary.
- Screw the expander heads fully onto the expanding tool (they must not become detached from the pipe during the rotation).
- The minimum distance between the end of the pipe and the compression sleeve must be observed and must be at least twice the length of the compression sleeve.
- Expand the pipe evenly.
- Do not heat up the pipe locally using a flame or warm air.
- Only REHAU compression sleeve fittings (no items from other manufacturers) may be inserted into the expanded pipe end.
- If cracks appear in the expanded area or if pipe ends have not been expanded according to specifications, cut off the damaged pipe end and repeat the expansion process.
- Check the pipe cutter blade for damages and replace the blade or cutter, if needed.

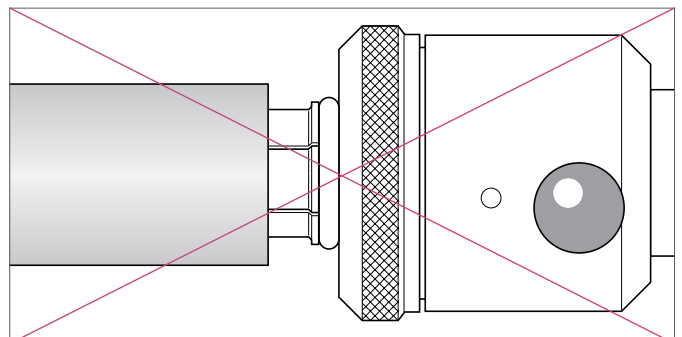
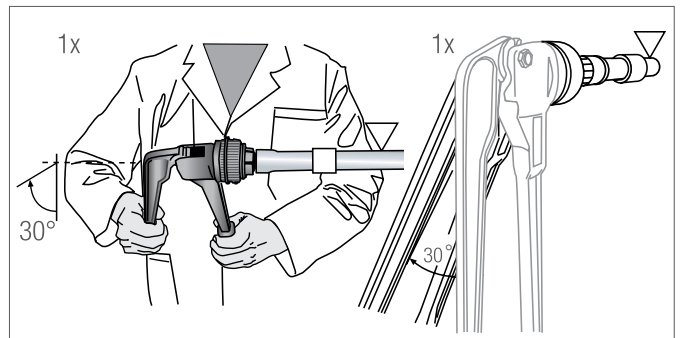
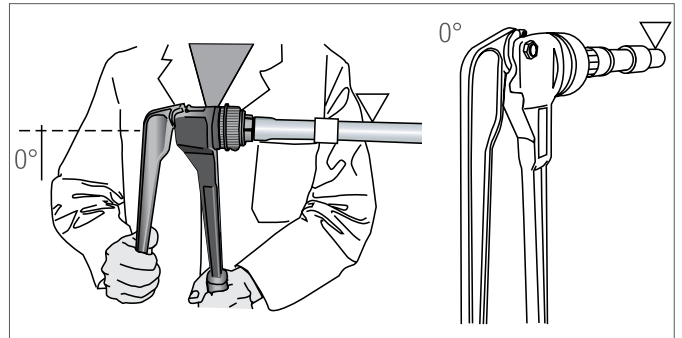

## Insert fitting

Insert the fitting into the expanded pipe immediately after expansion (or up to the end collar).

If the pipe has been expanded correctly, the fitting can be fully inserted into the expanded pipe without any major resistance. After a brief period, the fitting fits firmly in the pipe as the pipe contracts again (memory effect).

All sealing ribs must be covered by the pipe during this process.

Make sure the fitting is correctly positioned in the tool!  
Applying the tool to the wrong fitting coil will over-compress the connection!

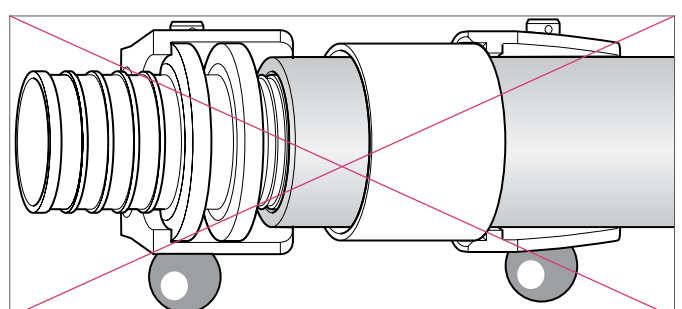

## Compression

Immediately after expansion, insert the fitting into the expanded pipe up to the stop. You should be able to insert it without any resistance. Insert the compression sleeve joint into the compression tool and fully compress without tilting. The joint can then be pressurized immediately, and the full temperature applied to it.

1. Press the push button or foot lever on the tool.
2. The compression sleeve must be fully compressed.
3. Visually inspect the joint for damage.



- The joint must be applied stress-free on pipe sections.

- Do not tilt uncompressed joints when inserting them into the tool/during the compression process, and always ensure that the tool is fully attached.
- The compression sleeve must be fully compressed.
- Do not use lubricants, water or similar when creating the compression sleeve joint.



Always attach compression jaws or compression tools fully and at a right angle!

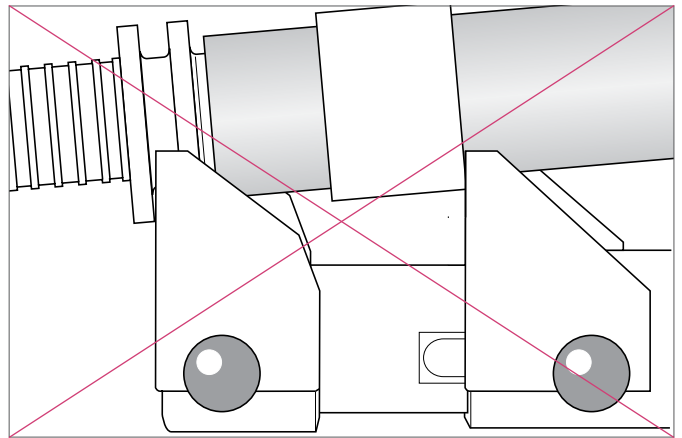

### Warning:

Do not touch moving parts (risk of trapping fingers)!

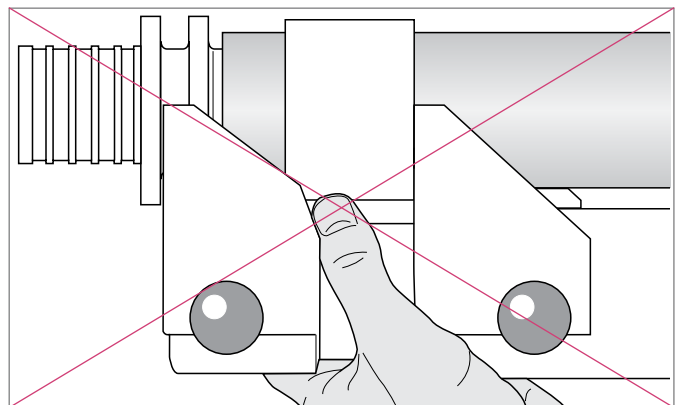

## Complete joint.

Proceed as above for the further fitting outlets.

Subsequently restore the insulation as per the corresponding installation instructions. For RAUVITHERM with a heat-shrink shroud, for RAUTHERMEX with a clip or heat-shrink shroud.



# HEAT SHRINK SHROUD INSTALLATION

## Apply heat-shrink sleeve

Push all heat-shrink sleeves onto the relevant pipe ends. The heat-shrink sleeves must not get dirty during this. Clean the pipe ends if required.



## Saw off the shroud ends

Saw off the shroud ends on the marked locations in line with the outer pipe diameter (see outer diameter information on the shroud).



Note the bottom and upper side of the shroud (see shroud print).



## Push on shroud

Push the upper end of the T-shroud onto the RAUVITHERM pipe.



## Compress further outlets

Install additional pipes in line with the previous steps.



## Push back shroud

Push the RAUVITHERM shroud back over the carrier pipe joint. The pipe can be inserted into the shroud with a maximum angle deviation of 20°.



### Butyl sealing tape

Apply a double layer of butyl tape to the sealing gap of the shroud of the T- and L-shell as shown in the picture.



The sealing tape must protrude approx. 2 mm on the outer edge of the shroud.



### Remove adhesive tape

Completely remove the adhesive protection from the sealing tape and press both shroud sides together.



### Puncturing screw holes

Puncture the sealing tape on the screw openings for example with a screwdriver. The holes can be centered during the puncturing process with a screw driver.



### Screwing together

Close the sides of the shroud using the screws enclosed. To do this, use an electrical screwdriver and press the protruding sealing tape firmly against the shroud.



## Sleeve drill and caulking

### Drilling

Make a ventilation hole on one of the marked locations on the uppermost point of the sleeve using a Forstner bit ( $d = 25 \text{ mm}$ ).

### Sealing

Seal the gap between the shroud and the pipe on the upper side of the shroud using a wide adhesive tape.



### Roughen shroud

Remove dirt and grease from the surface of the shroud. Roughen the surface of the shroud up to the marked location in the area of the heat-shrinkable sleeve with an emery strip.



### Shrinking on

Shrink two heat-shrink sleeves over the two lower ends of the T-shroud (preferably at the transit point). Shrink just one heat-shrink sleeve for I- and L-shrouds. Following this, warm up the shroud and pipe surface in the shrinking area and, immediately afterwards, shrink the sleeve with a soft flame evenly over the circumference of the shroud.



Pay attention to the limit markings on the shroud ends. Start shrinking on the heat-shrink sleeve onto the shroud area. Allow this area to cool down and proceed with shrinking on in the pipe area.

## Mixing foam components

Fill the smaller of the two foam components into the large bottle. Observe the enclosed installation instructions when doing this.



### Danger, severe chemical reaction!

The foam must not be stored in the sun prior to processing. Otherwise, the foam components can react very quickly and in an uncontrolled manner. Always wear protective goggles and protective gloves when working with foam.



The foam can be processed at a usage temperature of 18 – 23 °C. The surface temperature of the shroud and the pipeline should be between 15 – 45 °C. The foam components should be stored protected from frost prior to processing, ideally between 15 - 20°C. Please observe the instructions of the foam components for this!



## Shaking foam bottle

Shake the closed foam bottle as per user manual "foam set".



## Filling foam

Fill the content of the foam bottle into the remaining plug hole using the nozzle end.

The mix turns into rigid foam. The process starts at a processing temperature of approx. 20 °C after approx. 60 seconds and is complete after approx. 4 minutes. The mix can react quicker or slower at different processing temperatures.



## Close shroud

Remove any foam residues if required. Push the sealing plug halfway into the opening.



### Heat-shrinking

Shrink the remaining heat-shrink sleeve over the higher side of the T-shroud as per instructions of previous shrinkage processes.



## ADDITIONAL INFORMATION

With REHAU's heat-shrink shroud system for T-, L- and I-joints, not only can RAUTHERMEX or RAUVITHERM pipes be insulated, but also combinations of RAUTHERMEX pipes (e.g. main pipeline), RAUVITHERM pipes (e.g. service line to houses) and smooth outer jacket pipes (e.g. special components).



This document is protected by copyright. All rights based on this are reserved. No part of this publication may be translated, reproduced or transmitted in any form or by any similar means, electronic or mechanical, photocopying, recording or otherwise, or stored in a data retrieval system.

Our verbal and written advice with regard to usage is based on years of experience and standardised assumptions and is provided to the best of our knowledge. The intended use of REHAU products is described comprehensively in the technical product information. The latest version can be viewed at [www.rehau.com/TL](http://www.rehau.com/TL). We have no control over the application, use or processing of the products. Responsibility for these activities therefore remains entirely with the respective user/processor. Where claims for liability nonetheless arise, they shall be governed exclusively according to our terms and conditions, available at [www.rehau.com/conditions](http://www.rehau.com/conditions), insofar as nothing else has been agreed upon with REHAU in writing. This shall also apply for all warranty claims, with the warranty applying to the consistent quality of our products in accordance with our specifications. Subject to technical changes.

#### REHAU SALES OFFICES

**AE: Middle East**, +971 4 8835677, [dubai@rehau.com](mailto:dubai@rehau.com) **AR: Buenos Aires**, +54 11 48986000, [buenosaires@rehau.com](mailto:buenosaires@rehau.com) **AT: Linz**, +43 732 3816100, [linz@rehau.com](mailto:linz@rehau.com) **Wien**, +43 2236 24684, [wien@rehau.com](mailto:wien@rehau.com) **AU: Adelaide**, +61 8 82990031, [adelaide@rehau.com](mailto:adelaide@rehau.com) **Brisbane**, +61 7 55271833, [brisbane@rehau.com](mailto:brisbane@rehau.com) **Melbourne**, +61 3 95875544, [melbourne@rehau.com](mailto:melbourne@rehau.com) **Perth**, +61 8 94564311, [perth@rehau.com](mailto:perth@rehau.com) **Sydney**, +61 2 87414500, [sydney@rehau.com](mailto:sydney@rehau.com) **AZ: Baku**, +99 412 5110792, [baku@rehau.com](mailto:baku@rehau.com) **BA: Sarajevo**, +387 33 475500, [sarajevo@rehau.com](mailto:sarajevo@rehau.com) **BE: Bruxelles**, +32 16 399911, [bruxelles@rehau.com](mailto:bruxelles@rehau.com) **BG: Sofia**, +359 2 8920471, [sofia@rehau.com](mailto:sofia@rehau.com) **BR: Arapongas**, +55 43 31522004, [arapongas@rehau.com](mailto:arapongas@rehau.com) **Belo Horizonte**, +55 31 33097737, [belohorizonte@rehau.com](mailto:belohorizonte@rehau.com) **Caxias do Sul**, +55 54 32146606, [caxias@rehau.com](mailto:caxias@rehau.com) **Mirassol**, +55 17 32535190, [mirassol@rehau.com](mailto:mirassol@rehau.com) **Recife**, +55 81 32028100, [recife@rehau.com](mailto:recife@rehau.com) **BY: Minsk**, +375 17 2450209, [minsk@rehau.com](mailto:minsk@rehau.com) **CA: Moncton**, +1 506 5382346, [moncton@rehau.com](mailto:moncton@rehau.com) **Montreal**, +1 514 9050345, [montreal@rehau.com](mailto:montreal@rehau.com) **Toronto**, +1 905 3353284, [toronto@rehau.com](mailto:toronto@rehau.com) **Vancouver**, +1 604 6264666, [vancouver@rehau.com](mailto:vancouver@rehau.com) **CH: Bern**, +41 31 720120, [bern@rehau.com](mailto:bern@rehau.com) **Vevey**, +41 21 9482636, [vevey@rehau.com](mailto:vevey@rehau.com) **Zuerich**, +41 44 8397979, [zuerich@rehau.com](mailto:zuerich@rehau.com) **CN: Guangzhou**, +86 20 87760343, [guangzhou@rehau.com](mailto:guangzhou@rehau.com) **Beijing**, +86 10 64282956, [beijing@rehau.com](mailto:beijing@rehau.com) **Shanghai**, +86 21 63551155, [shanghai@rehau.com](mailto:shanghai@rehau.com) **Chengdu**, +86 28 86283218, [chengdu@rehau.com](mailto:chengdu@rehau.com) **Xian**, +86 29 68597000, [xian@rehau.com](mailto:xian@rehau.com) **Shenyang**, +86 24 22876807, [shenyang@rehau.com](mailto:shenyang@rehau.com) **CO: Bogota**, +57 1 898 528687, [bogota@rehau.com](mailto:bogota@rehau.com) **CZ: Praha**, +420 272 190111, [paha@rehau.com](mailto:paha@rehau.com) **DE: Bielefeld**, +49 521 208400, [bielefeld@rehau.com](mailto:bielefeld@rehau.com) **Bochum**, +49 234 689030, [bochum@rehau.com](mailto:bochum@rehau.com) **Frankfurt**, +49 6074 40900, [frankfurt@rehau.com](mailto:frankfurt@rehau.com) **Hamburg**, +49 40 733402100, [hamburg@rehau.com](mailto:hamburg@rehau.com) **Hannover**, +49 5136 891181, [hannover@rehau.com](mailto:hannover@rehau.com) **Leipzig**, +49 34292 820, [leipzig@rehau.com](mailto:leipzig@rehau.com) **München**, +49 8102 860, [muenchen@rehau.com](mailto:muenchen@rehau.com) **Nürnberg**, +49 9131 934080, [nuernberg@rehau.com](mailto:nuernberg@rehau.com) **Stuttgart**, +49 7159 16010, [stuttgart@rehau.com](mailto:stuttgart@rehau.com) **Ingolstadt**, +49 841 142626200, [ingolstadt@rehau.com](mailto:ingolstadt@rehau.com) **DK: Kobenhavn**, +45 46 773700, [kobenhavn@rehau.com](mailto:kobenhavn@rehau.com) **EE: Tallinn**, +372 6025850, [tallinn@rehau.com](mailto:tallinn@rehau.com) **ES: Barcelona**, +34 93 6353500, [barcelona@rehau.com](mailto:barcelona@rehau.com) **Bilbao**, +34 94 4538636, [bilbao@rehau.com](mailto:bilbao@rehau.com) **Madrid**, +34 91 6839425, [madrid@rehau.com](mailto:madrid@rehau.com) **FI: Helsinki**, +358 9 87709900, [helsinki@rehau.com](mailto:helsinki@rehau.com) **FR: Lyon**, +33 4 72026300, [lyon@rehau.com](mailto:lyon@rehau.com) **Metz**, +33 6 8500, [metz@rehau.com](mailto:metz@rehau.com) **Paris**, +33 1 34836450, [paris@rehau.com](mailto:paris@rehau.com) **GB: Glasgow**, +44 1698 503700, [glasgow@rehau.com](mailto:glasgow@rehau.com) **Manchester**, +44 161 7777400, [manchester@rehau.com](mailto:manchester@rehau.com) **Slough**, +44 1753 588500, [slough@rehau.com](mailto:slough@rehau.com) **Ross on Wye**, +44 1989 762643, [rossonwye@rehau.com](mailto:rossonwye@rehau.com) **London**, +44 207 3078590, [london@rehau.com](mailto:london@rehau.com) **GE: Tbilisi**, +995 32 559909, [tbilisi@rehau.com](mailto:tbilisi@rehau.com) **GR: Athens**, +30 21 06682500, [athens@rehau.com](mailto:athens@rehau.com) **Thessaloniki**, +30 2310 633301, [thessaloniki@rehau.com](mailto:thessaloniki@rehau.com) **HK: Hongkong**, +852 28987080, [hongkong@rehau.com](mailto:hongkong@rehau.com) **HR: Zagreb**, +385 1 3444711, [zagreb@rehau.com](mailto:zagreb@rehau.com) **HU: Budapest**, +36 23 530700, [budapest@rehau.com](mailto:budapest@rehau.com) **ID: Jakarta**, +62 21 45871030, [jakarta@rehau.com](mailto:jakarta@rehau.com) **IE: Dublin**, +353 1 8165020, [dublin@rehau.com](mailto:dublin@rehau.com) **IN: Mumbai**, +91 22 61485858, [mumbai@rehau.com](mailto:mumbai@rehau.com) **New Delhi**, +91 11 45044700, [newdelhi@rehau.com](mailto:newdelhi@rehau.com) **Bangalore**, +91 80 2222001314, [bangalore@rehau.com](mailto:bangalore@rehau.com) **IT: Pesaro**, +39 0721 200611, [pesaro@rehau.com](mailto:pesaro@rehau.com) **Roma**, +39 06 90061311, [roma@rehau.com](mailto:roma@rehau.com) **Treviso**, +39 0422 726511, [treviso@rehau.com](mailto:treviso@rehau.com) **JP: Tokyo**, +81 3 57962102, [tokyo@rehau.com](mailto:tokyo@rehau.com) **KR: Seoul**, +82 2 5011656, [seoul@rehau.com](mailto:seoul@rehau.com) **KZ: Almaty**, +7 727 3941301, [almaty@rehau.com](mailto:almaty@rehau.com) **LT: Vilnius**, +370 5 2461400, [vilnius@rehau.com](mailto:vilnius@rehau.com) **LV: Riga**, +371 6 7609080, [riga@rehau.com](mailto:riga@rehau.com) **MA: Casablanca**, +212 522250593, [casablanca@rehau.com](mailto:casablanca@rehau.com) **MK: Skopje**, +389 22402 670, [skopje@rehau.com](mailto:skopje@rehau.com) **MX: Celaya**, +52 461 6188000, [celaya@rehau.com](mailto:celaya@rehau.com) **Monterrey**, +52 81 81210130, [monterrey@rehau.com](mailto:monterrey@rehau.com) **NL: Nijkerk**, +31 33 2479911, [nijkerk@rehau.com](mailto:nijkerk@rehau.com) **NO: Oslo**, +47 2 2514150, [oslo@rehau.com](mailto:oslo@rehau.com) **NZ: Auckland**, +64 9 2722264, [auckland@rehau.com](mailto:auckland@rehau.com) **PE: Lima**, +51 1 2261713, [lima@rehau.com](mailto:lima@rehau.com) **PL: Poznań**, +48 61 8498400, [poznan@rehau.com](mailto:poznan@rehau.com) **PT: Lisboa**, +351 21 8987050, [lisboa@rehau.com](mailto:lisboa@rehau.com) **Oporto**, +351 2294464, [oporto@rehau.com](mailto:oporto@rehau.com) **QA: Qatar**, +974 44101608, [qatar@rehau.com](mailto:qatar@rehau.com) **RO: Bacau**, +40 234 512066, [bacau@rehau.com](mailto:bacau@rehau.com) **Bucuresti**, +40 21 2665180, [bucuresti@rehau.com](mailto:bucuresti@rehau.com) **Ciuj Napoca**, +40 264 415211, [ciujnapoca@rehau.com](mailto:ciujnapoca@rehau.com) **RS: Beograd**, +381 11 3770301, [beograd@rehau.com](mailto:beograd@rehau.com) **RU: Chabarovsk**, +7 4212 411218, [chabarowsk@rehau.com](mailto:chabarowsk@rehau.com) **Jekaterinburg**, +7 343 2535305, [jekaterinburg@rehau.com](mailto:jekaterinburg@rehau.com) **Krasnodar**, +7 861 2103636, [krasnodar@rehau.com](mailto:krasnodar@rehau.com) **Nishnij Nowgorod**, +7 831 4678078, [nishnijnowgorod@rehau.com](mailto:nishnijnowgorod@rehau.com) **Novosibirsk**, +7 3832 000353, [novosibirsk@rehau.com](mailto:novosibirsk@rehau.com) **Rostow am Don**, +7 8632 978444, [rostow@rehau.com](mailto:rostow@rehau.com) **Samara**, +7 8462 698058, [samara@rehau.com](mailto:samara@rehau.com) **St. Petersburg**, +7 812 3266207, [spetersburg@rehau.com](mailto:spetersburg@rehau.com) **Woronesch**, +7 4732 611858, [woronesch@rehau.com](mailto:woronesch@rehau.com) **SE: Örebro**, +46 19 206400, [orebro@rehau.com](mailto:orebro@rehau.com) **SG: Singapore**, +65 63926006, [singapore@rehau.com](mailto:singapore@rehau.com) **SK: Bratislava**, +421 2 68209110, [bratislava@rehau.com](mailto:bratislava@rehau.com) **TH: Bangkok**, +66 27635100, [bangkok@rehau.com](mailto:bangkok@rehau.com) **TW: Taipei**, +886 2 87803899, [taipei@rehau.com](mailto:taipei@rehau.com) **UA: Dnepropetrowsk**, +380 56 3705028, [dnepropetrowsk@rehau.com](mailto:dnepropetrowsk@rehau.com) **Kiev**, +380 44 4677710, [kiev@rehau.com](mailto:kiev@rehau.com) **Odessa**, +380 48 7800708, [odessa@rehau.com](mailto:odessa@rehau.com) **Riga**, +380 32 2958920, [liv@rehau.com](mailto:liv@rehau.com) **US: Detroit**, +1 248 8489100, [detroit@rehau.com](mailto:detroit@rehau.com) **Grand Rapids**, +1 616 2856867, [grandrapids@rehau.com](mailto:grandrapids@rehau.com) **Los Angeles**, +1 951 5499017, [losangeles@rehau.com](mailto:losangeles@rehau.com) **Minneapolis**, +1 612 2530576, [minneapolis@rehau.com](mailto:minneapolis@rehau.com) **VN: Ho Chi Minh City**, +84 8 38233030, [sales.vietnam@rehau.com](mailto:sales.vietnam@rehau.com) **ZA: Durban**, +27 31 7657447, [aurban@rehau.com](mailto:aurban@rehau.com) **Johannesburg**, +27 11 2011300, [johannesburg@rehau.com](mailto:johannesburg@rehau.com) **Cape Town**, +27 21 9821254, [capetown@rehau.com](mailto:capetown@rehau.com) **East London**, +27 43 7095400, [eastlondon@rehau.com](mailto:eastlondon@rehau.com) **If there is no sales office in your country**, +49 9131 925888, [salesoffice.ibd@rehau.com](mailto:salesoffice.ibd@rehau.com)

© REHAU AG + Co  
Rheniumhaus  
95111 Rehau (Germany)

Subject to technical changes

817609 EN 11.2019